

Statement of Line

*Carrington wood side chairs are timeless in design and convey elegance throughout all areas of the corporate environment. Ideal for guest conferencing and dining, Carrington's shapes and contours blend to achieve an ideal balance of comfort and support.*

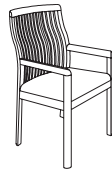

**High Back with Slat Back**

➤ See page 53 to specify.

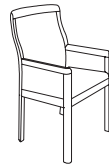

**High Back with Upholstered Back**

➤ See page 53 to specify.



**Mid-Back with Slat Back**

➤ See page 53 to specify.

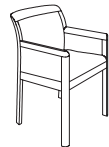

**Mid-Back with Upholstered Back**

➤ See page 53 to specify.

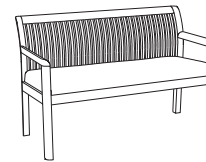

**Bench with Slat Back**

➤ See page 53 to specify.

➤ See page

Finishes & Materials	211
Overview	52
Actual Dimensions	52

# Carrington

## Overview

### Design Variations:



Slat Back



Upholstered Back

**Two different back styles** are available on Carrington side chairs; each is available as a high back or mid-back. Two-seat bench is available with slat back.

**Frame** is constructed of kiln-dried cherry or maple hardwoods.

*Note: Cherry models use cherry and other select hardwoods.*

**Joints** are double doweled and securely glued to ensure maximum strength.

**Corners** are reinforced with wood corner blocks and tie screws.

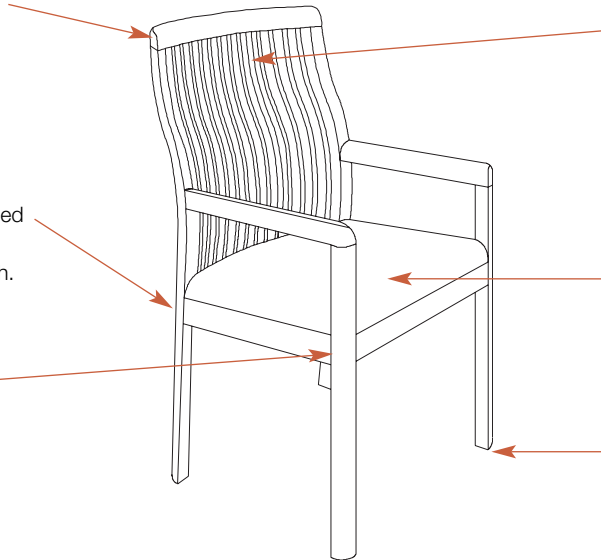

**Slats** on slat back models are individually shaped and hand set using mortise and tenon joints to prevent twisting.

**Cushions** are high resiliency, CFC-free polyurethane foam.

**Nylon glides** are 7/8" in diameter.

### Features

**Seat suspension** is constructed of of molded plywood that is machined to form an open perimeter. Unidirectional webbing is machine stretched across the open perimeter and stapled to the edges to form a suspension.

**Seat cushion**, applied to the flexible webbing suspension, is 3¾" thick on high back and mid-back chairs and 4" thick on two-seat bench.

**Seat upholstery** is wrapped over the seat cushion and secured to the seat suspension with upholstery staples. The entire seat assembly is fitted into the frame with wood screws inserted into the wood corner blocks.

**Back on upholstered back model** is constructed using molded plywood that is secured to the frame with wood dowels and screws. 1½" thick foam is applied to the plywood panel on the inside back of highback models (foam is 1¼" on mid-back models); ¾" thick foam is applied to

the outside back. Upholstery is wrapped over the foam and secured with upholstery staples.

**Arms on upholstered back chairs** have upholstered wood inserts shaped to fit the inner arm of the chair frame. ¼" thick foam covers both sides of the 1½" thick panels. Arm inserts are held in place with wood dowels and screws.

### Actual Dimensions:

<b>High Back</b>	83308, 83310, 83408, & 83410
Height	37"
Width	23¼"
Depth	24¼"
Arm height	24"
Seat height	18"
Seat width	20"
Seat depth	19"
<b>Mid-Back</b>	83309, 83311, 83409, & 83411
Height	31"
Width	23¼"
Depth	24"
Arm height	24"
Seat height	18"
Seat width	20"
Seat depth	19"
<b>Bench</b>	83422
Height	31"
Width	47"
Depth	23¼"
Arm height	24"
Seat height	18"
Seat width	43¾"
Seat depth	19¼"

▶ See page

Finishes &amp; Materials 211

COM/COL Yardage Req. 246

Alliance Program Pricing 54

**Specifying Tips:**

- TB133 fire code treatment is available on select upholstery.
  - ▶ See page 219 for upholstery.
  - ▶ See page 255 for TB133 pricing.
  - ▶ See page 267 for COM or COL.
- Faux leather upholstery with TB133 option are not available on Carrington upholstered back models.

**How to Specify:**

- ① Model
- ② Upholstery grade
- ③ Upholstery number
- ④ Finish price group:  
**STD** = Group 1
- ⑤ Finish designator

Sample (base model underlined):

① ② ③ ④ ⑤  
83308 2 20020 STD MC

**Carrington****Side Chairs and Benches****Kimball Office Upholstery Price Grade**

Model	Wood	1 or COM	2	3 or COL	4	5	6	7	L7	L8
-------	------	----------	---	----------	---	---	---	---	----	----

**High Back***Slat Back*

<b>83308</b>	Cherry	\$1432	\$1455	\$1470	\$1485	\$1506	\$1528	\$1550	\$1642	\$1694
<b>83408</b>	Maple	1432	1455	1470	1485	1506	1528	1550	1642	1694

*Upholstered Back*

<b>83310</b>	Cherry	\$1432	\$1481	\$1512	\$1544	\$1588	\$1636	\$1684	\$1879	\$1990
<b>83410</b>	Maple	1432	1481	1512	1544	1588	1636	1684	1879	1990

**Mid-Back***Slat Back*

<b>83309</b>	Cherry	\$1309	\$1332	\$1347	\$1362	\$1383	\$1405	\$1427	\$1519	\$1571
<b>83409</b>	Maple	1309	1332	1347	1362	1383	1405	1427	1519	1571

*Upholstered Back*

<b>83311</b>	Cherry	\$1309	\$1350	\$1375	\$1401	\$1438	\$1477	\$1516	\$1677	\$1768
<b>83411</b>	Maple	1309	1350	1375	1401	1438	1477	1516	1677	1768

**Bench***Slat Back*

<b>83422</b>	Maple	\$1881	\$1904	\$1919	\$1934	\$1955	\$1977	\$1999	\$2091	\$2143
--------------	-------	--------	--------	--------	--------	--------	--------	--------	--------	--------

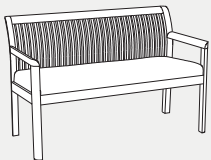
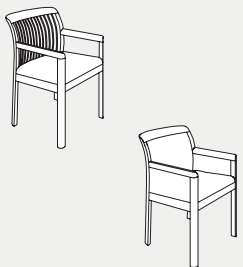
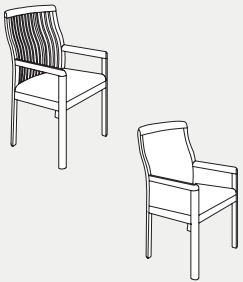

## Carrington

## with Alliance Program Upholstery

**IMPORTANT:** Orders cannot be cancelled for chairs specified with Alliance Program upholstery.

Model	Alliance Upholstery Price Grade									
	A	B	C	D	E	F	G	H	I	
	J	K	L	M	N	O	P	Q	R	
<b>83308</b>	\$1467	\$1482	\$1496	\$1508	\$1523	\$1539	\$1550	\$1566	\$1582	
	1597	1622	1672	1704	1708	1716	1724	1732	1766	
<b>83309</b>	1344	1359	1373	1385	1400	1416	1427	1443	1459	
	1474	1499	1549	1581	1585	1593	1601	1609	1643	
<b>83310</b>	1507	1539	1568	1594	1626	1660	1682	1718	1752	
	1782	1835	1942	2010	2019	2036	2053	2070	2141	
<b>83311</b>	1371	1397	1421	1442	1469	1497	1515	1544	1572	
	1597	1641	1729	1785	1792	1806	1820	1834	1893	
<b>83408</b>	1467	1482	1496	1508	1523	1539	1550	1566	1582	
	1597	1622	1672	1704	1708	1716	1724	1732	1766	
<b>83409</b>	1344	1359	1373	1385	1400	1416	1427	1443	1459	
	1474	1499	1549	1581	1585	1593	1601	1609	1643	
<b>83410</b>	1507	1539	1568	1594	1626	1660	1682	1718	1752	
	1782	1835	1942	2010	2019	2036	2053	2070	2141	
<b>83411</b>	1371	1397	1421	1442	1469	1497	1515	1544	1572	
	1597	1641	1729	1785	1792	1806	1820	1834	1893	
<b>83422</b>	1916	1931	1945	1957	1972	1988	1999	2015	2031	
	2046	2071	2121	2153	2157	2165	2173	2181	2215	

## Specifying Tips:

- TB133 fire code treatment is available on select upholstery.  
▶ See page 267 for process overview.

## How to Specify:

- ① Model
- ② Alliance partner designator and upholstery grade:  
**CAR**[grade] = Carnegie  
**KNL**[grade] = KnollTextiles  
**MHM**[grade] = Maharam  
**MAF**[grade] = Mayer Fabrics
- ③ Upholstery number
- ④ Finish price group:  
**STD** = Group 1
- ⑤ Finish designator

Sample (base model underlined):

① ② ③  
83308 CARJ 6136\_10  
④ ⑤  
STD MC