

Fundamental

Statement of Line

Fundamental lateral files offer simple filing solutions for a variety of needs. Fundamental is available in four heights. Five-high lateral files are available in ADA-compliant models, with a fixed shelf and lift door in the top position, or with a posting shelf for convenient standing workspace.

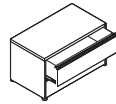

2-High Lateral Files
 ▶ See page 23 to specify.

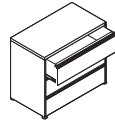

3-High Lateral Files
 ▶ See page 23 to specify.

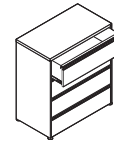

4-High Lateral Files
 ▶ See page 23 to specify.

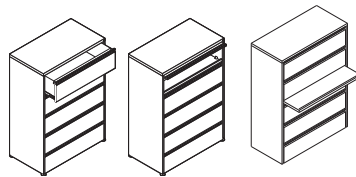

5-High Lateral Files
 Available with five drawers, four drawers and fixed shelf with lift door, or five drawers and posting shelf.
 ▶ See page 24 to specify.

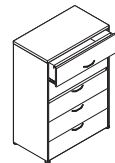

5-High Lateral Files, ADA Compliant
 ▶ See page 24 to specify.

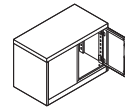

Overfiles
 ▶ See page 25 to specify.

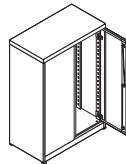

Storage Cabinets
 ▶ See page 25 to specify.

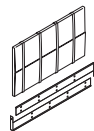

Counterweight Kits
 ▶ See page 26 to specify.

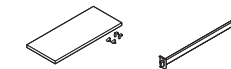

Shelves and Storage Wardrobe Kits
 ▶ See page 26 to specify.

▶ See page

Finishes & Materials	29
Overview	20
Filing Capacities	22

Finishes and Materials:

Lateral Files, Overfiles, Storage Cabinets

- Metal: paint

Drawer Interiors and Shelves

- Black paint

Extended Pulls

- Painted to match cabinet

Arc Pulls

- Metal: paint
 - 462 Cinder
 - 485 Dark Chocolate
 - 501 Platinum Metallic
 - 503 Satin Nickel
 - 505 Bronze Metallic
 - 514 Carbon Metallic

Rail Pulls

- Textured, black

Locks

- Black

Fundamental

Overview

Details:

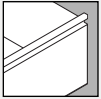

Extended

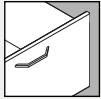

Rail Pull



Arc Pull

Three drawer pulls are available on Fundamental files.

Extended drawer pull is recessed along the full front edge.

Replacement drawer fronts can be field installed.

Top is finished so the file can be used as a stand alone unit.

Knockouts are standard for ganging side-by-side or for securing to a wall.

Fixed shelf with lift door on applicable five-high lateral files replaces top drawer and accommodates standing binders up to 12"H.

Counterweight kit, specified separately, is required for all individual freestanding units. Kits include counterweight and bracket, packaged individually.

Four glides, standard, provide 1" adjustability and allow for sturdy, four-point loading.

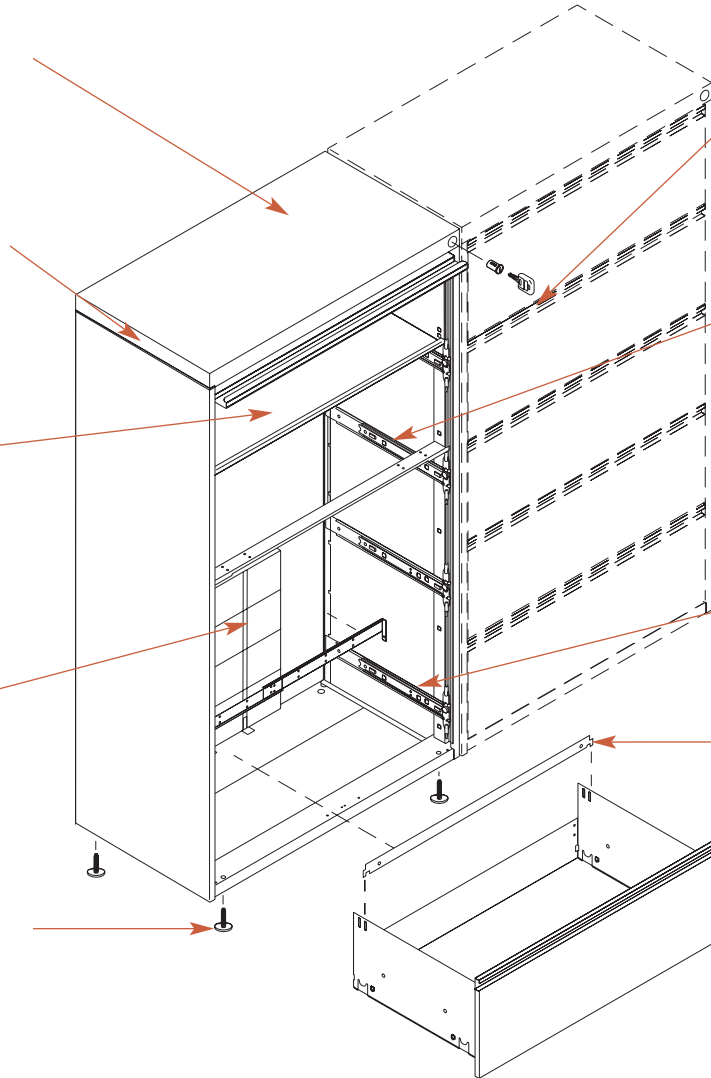

Locking is standard. Select key random or key specific.
Note: Lock cores must be specified separately for key specific option.

Integrated drawer slide and single interlock mechanism is part of the slide design, providing for quieter drawer operation and ensuring only one drawer may be opened at a time.

Full ball-bearing drawer suspension allows both the drawer and suspension to extend together.

Side-to-side file bars are standard; two per drawer.

Front-to-back file bars are available separately for easy field installation.

Label holder is standard with extended pull; one per drawer.

Product Information

Related Products:

Counterweight kit, specified separately, is required for all individual freestanding units.

➤ See page 26.

Laminate file tops are available to provide a continuous worksurface over one or more files.

➤ See page 28.

Paper management accessories are available.

➤ See page 27.

Lateral Files

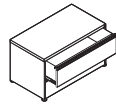

Construction features coach seam welds. Right angle bend of the coach seam makes the strongest use of formed metal and presents a clean exterior with no exposed welds.

Progressive slide suspension provides smooth drawer operation.

Steel drawer interiors are pre-painted cinder.

ADA compliant lateral files feature the choice of rail or arc pull. The lock is placed at 38⁵/₈"H, making it accessible from a seated position.

Posting shelf, available on five-high lateral file, includes magnetic spring latch to open and close. Posting shelf is located above the third drawer.

Drawer fronts and lift doors in the top position on five-high lateral files are 1⁹/₁₆" taller than the other drawer fronts to accommodate the receding lift-door application.

Exception: Drawer fronts on models with posting shelf are all the same height. Posting shelf is 1³/₈"H.

Letter, legal and A4 filing is accommodated with conventional or hanging folders.

➤ See page 22 for filing capabilities.

Side-to-side legal or letter filing can be accommodated with file bars that ship standard in file.

Four adjustable glides are standard, providing 1" adjustability.

Overfile

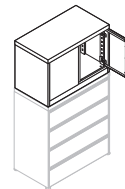

Hinged doors are standard.

Locking is standard. Select key random or key specific.
Note: Lock cores must be specified separately for key specific option.

➤ See page 4.

IMPORTANT: Shelves are specified separately for field installation. They are not included with the overfile.

Overfile can be used independently or in addition to any appropriate width Fundamental file or storage cabinet.

Knockouts are standard for ganging side-by-side.

Storage Cabinet

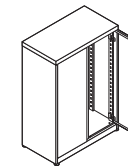

Hinged doors are standard.

Locking is standard. Select key random or key specific.
Note: Lock cores must be specified separately for key specific option.
➤ See page 4.

IMPORTANT: Shelves and wardrobe kits are specified separately for field installation. They are not included with the storage cabinet.

Knockouts are standard for ganging side-by-side.

Four adjustable glides are standard and provide 1" adjustability.

Fundamental

Filing Capacities

Filing Hardware:

Heavier lines in the illustrations at right indicate filing rails.

Front-to-back file bars can be specified separately.



➤ See the Perks Price List.

Side-to-side file bars are standard; two per drawer.

➤ See page 27.

Drawer divider can be specified separately.

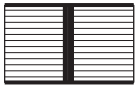
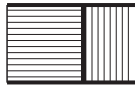
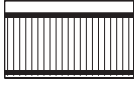
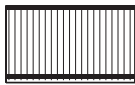
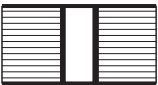
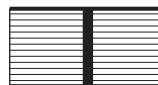
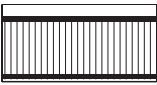
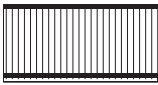
➤ See page 27.

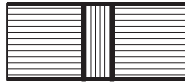
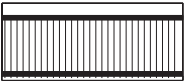
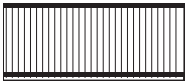
<i>Description</i>	<i>Inside Depth</i>	<i>Inside Width</i>	<i>Height</i>	<i>Filing Arrangements</i>			
18"D x 30"W lateral	14 ⁷ / ₈ "	26 ⁷ / ₈ "	9 ³ / ₈ "				
				29 ⁵ / ₈ " letter Front-to-back file bars (2) Side-to-side file bars (2)	25 ¹ / ₄ " legal Front-to-back file bar (1) Side-to-side file bars (2)	26 ¹³ / ₁₆ " letter Side-to-side file bars (2)	26 ¹³ / ₁₆ " legal Side-to-side file bars (2)
18"D x 36"W lateral	14 ⁷ / ₈ "	32 ⁷ / ₈ "	9 ³ / ₈ "				
				29 ⁵ / ₈ " letter Front-to-back file bars (2) Side-to-side file bars (2)	29 ⁵ / ₈ " legal Front-to-back file bars (2) Side-to-side file bars (2)	32 ¹³ / ₁₆ " letter Side-to-side file bars (2)	32 ¹³ / ₁₆ " legal Side-to-side file bars (2)
18"D x 42"W lateral	14 ⁷ / ₈ "	38 ⁷ / ₈ "	9 ³ / ₈ "				
				44 ⁷ / ₁₆ " letter Front-to-back file bar (2) Side-to-side file bars (2)	35 ⁵ / ₈ " legal Front-to-back file bars (2) Side-to-side file bars (2)	38 ¹³ / ₁₆ " letter Side-to-side file bars (2)	38 ¹³ / ₁₆ " legal Side-to-side file bars (2)

Fundamental







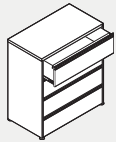
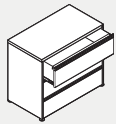
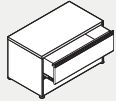

2-, 3-, and 4-High Lateral Files

 = Kwik Office model available.
 ▶ See the Kwik Office Price List.

▶ See page

Finishes & Materials	29
Counterweight Kits	26
Paper Management	27



<i>D</i>	<i>W</i>	<i>H</i>	<i>Model</i>	<i>Price</i>
2-High Lateral Files				
18"	30"	27 ¹ / ₄ "	FND18302 	\$750
		36"	FND18362 	815
		42"	FND18422 	878
3-High Lateral Files				
18"	30"	39 ³ / ₁₆ "	FND18303 	\$876
		36"	FND18363 	996
		42"	FND18423 	1083
4-High Lateral Files				
18"	30"	51 ¹ / ₈ "	FND18304 	\$1065
		36"	FND18364 	1199
		42"	FND18424 	1353

Standard:

- Two, three, or four lateral file drawers
- Two side-to-side file bars per drawer
- Lock: black

Related Products:

- Counterweight kits
▶ See page 26.
- Front-to-back file bars
▶ See the Perks Price List.
- Laminate file tops
▶ See page 28.

Options:

<i>Description</i>	<i>How to Specify</i>	<i>Add/Deduct \$</i>
Key specific locking	Specify KSB	-\$21
IMPORTANT: Lock cores must be specified separately for key specific option. ▶ See page 4.		
Metallic paint	Specify STD for finish type and metallic paint designator	+10%

Specifying Tips:

- Counterweight kit, specified separately, is required for all freestanding lateral files.
- Front-to-back filing can be accommodated by ordering appropriate number of front-to-back file bars separately.

How to Specify:

- ① Model
- ② Pull option:
R = Rail, textured black
E = Extended, same paint as file
ARC462 = Arc, Cinder
ARC485 = Arc, Dark Chocolate
ARC501 = Arc, Platinum Metallic
ARC503 = Arc, Satin Nickel
ARC505 = Arc, Bronze Metallic
ARC514 = Arc, Carbon Metallic
- ③ Lock option:
KRB = Key random
KSB = Key specific (-\$)
- ④ Finish price group:
STD = Standard non-metallic
STD = Standard metallic (+\$)
- ⑤ Finish designator

Sample (base model underlined):

① ② ③ ④
FND18302 ARC503 KRB STD
 ⑤
 462

Fundamental

5-High Lateral Files

 = Kwik Office model available.
 ▶ See the Kwik Office Price List.

▶ See page

Finishes & Materials	29
Counterweight Kits	26
Paper Management	27

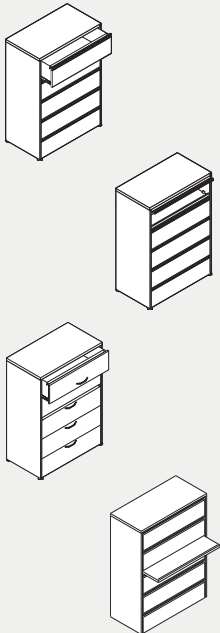









Standard:

- Five lateral file drawers (four drawers and fixed shelf and lift door on applicable models)
- Two side-to-side file bars per drawer
- Lock: black

Related Products:

- Front-to-back file bars
▶ See the Perks Price List.
- Counterweight kits
▶ See page 26.

D	W	H	Model	Description	Price
5-High Lateral Files					
18"	30"	64½"	FND18305 		\$1426
		36"	FND18365 		1562
		42"	FND18425 		1708
5-High Lateral Files with Fixed Shelf and Lift Door					
18"	30"	64½"	FND18305LD 		\$1490
		36"	FND18365LD 		1624
		42"	FND18425LD 		1769
5-High Lateral Files, ADA Compliant					
18"	30"	64½"	FND18305ADA 	Lock is located above third drawer.	\$1562
		36"	FND18365ADA 		1694
		42"	FND18425ADA 		1842
5-High Lateral Files with Posting Shelf					
18"	30"	64½"	FND18305PS	Posting shelf height is 1⅞".	\$1564
		36"	FND18365PS		1701
		42"	FND18425PS		1848

Options:

Description	How to Specify	Add/Deduct \$
Key specific locking	Specify KSB	-\$21
IMPORTANT: Lock cores must be specified separately for key specific option. ▶ See page 4.		
Metallic paint	Specify STD for finish type and metallic paint designator	+10%

Specifying Tips:

- Drawer fronts and lift doors in the top position are 1⅞" taller than the others.
Exception: All drawer fronts on model with posting shelf are the same height.
- Counterweight kit, specified separately, is required.
- Front-to-back filing can be accommodated by ordering front-to-back file bars separately.

How to Specify:

- ① Model
- ② Pull option:
R = Rail, textured black
E = Extended, same paint as file (not available on ADA model)
ARC462 = Arc, Cinder
ARC485 = Arc, Dark Chocolate
ARC501 = Arc, Platinum Metallic
ARC503 = Arc, Satin Nickel
ARC505 = Arc, Bronze Metallic
ARC514 = Arc, Carbon Metallic
- ③ Lock option:
KRB = Key random
KSB = Key specific (-\$)
- ④ Finish price group:
STD = Standard non-metallic
STDM = Standard metallic (+\$)
- ⑤ Finish designator

Sample (base model underlined):

① ② ③ ④
FND18305LD ARC503 KRB STD
 ⑤
 462

Overfiles and Storage Cabinets

K = Kwik Office model available.
 ▶ See the Kwik Office Price List.

▶ See page

Finishes & Materials	29
Shelves & Wardrobe Kits	26

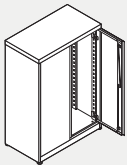
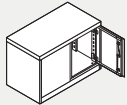

D	W	H	Model	Price
Overfiles				
18"	30"	29¼"	FND1830OF K	\$666
	36"		FND1836OF K	699
	42"		FND1842OF K	756
Storage Cabinets				
<i>2 High</i>				
18"	30"	27¼"	FND18302SC K	\$780
	36"		FND18362SC K	823
	42"		FND18422SC K	921
<i>3 High</i>				
18"	30"	39¾"	FND18303SC K	\$823
	36"		FND18363SC K	864
	42"		FND18423SC K	961
<i>4 High</i>				
18"	30"	51⅞"	FND18304SC K	\$864
	36"		FND18364SC K	914
	42"		FND18424SC K	1012
<i>5 High</i>				
18"	30"	64½"	FND18305SC K	\$911
	36"		FND18365SC K	967
	42"		FND18425SC K	1065

Specifying Tips:

- **IMPORTANT:** Shelves and wardrobe kits are specified separately for field installation. They are not included with the overfile or storage cabinet.
- Shelves are adjustable at 2" increments.

How to Specify:

- ① Model
- ② Keying option:
KRB = Key random
KSB = Key specific (- \$)
- ③ Finish price group:
STD = Standard non-metallic
STDM = Standard metallic (+\$)
- ④ Finish designator

Sample (base model underlined):

① ② ③ ④
FND18302SC KRB STD 462

Standard:

- Lock: black

Related Products:

- Shelf and wardrobe kits
 ▶ See page 26.
- Laminate file tops
 ▶ See page 28.

Options:

Description	How to Specify	Add/Deduct \$
Key specific locking	Specify KSB	-\$21
IMPORTANT: Lock cores must be specified separately for key specific option. ▶ See page 4.		
Metallic paint	Specify STDM for finish type and metallic paint designator	+10%

Accessories

K = Kwik Office model available.
 ▶ See the Kwik Office Price List.

▶ See page

Finishes & Materials 29

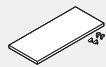
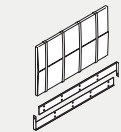

<i>D</i>	<i>W</i>	<i>H</i>	<i>Model</i>	<i>Description</i>	<i>Price</i>
Counterweight Kits					
11½"	23¼"	11½"	FNDACW K	Use with any width file	\$164
Overfile/Storage Cabinet Shelves					
16½"	28½"	1"	FND1830LFSHP K	Use with 30"W overfile/cabinet	\$71
	34½"		FND1836LFSHP K	Use with 36"W overfile/cabinet	74
	40½"		FND1842LFSHP K	Use with 42"W overfile/cabinet	77
Wardrobe Kits					
2¾"	29½"	3¾"	FND1830WB K	Use with 30"W storage cabinet; galvanized metal	\$63
	35½"		FND1836WB K	Use with 36"W storage cabinet; galvanized metal	69
	41½"		FND1842WB K	Use with 42"W storage cabinet; galvanized metal	71

Specifying Tips:

- Counterweight is required for freestanding files. Kit includes brackets that adjust to fit the width of any Fundamental file.
- Shelf is adjustable at 2" increments.

How to Specify:

Counterweight or Wardrobe Kit

- ① Model

Overfile/Storage Cabinet Shelves

- ① Model
 ② Finish price group:
STD = Standard non-metallic
STD M = Standard metallic (+\$)
 ③ Finish designator

Sample (base model underlined):

① ② ③
FND1830LFSHP STD 480

Options:

<i>Description</i>	<i>How to Specify</i>	<i>Add/Deduct \$</i>
Metallic paint on overfile/storage shelves	Specify STD M for finish type and metallic paint designator	+10%