

Hero

Seat Height Adjustment

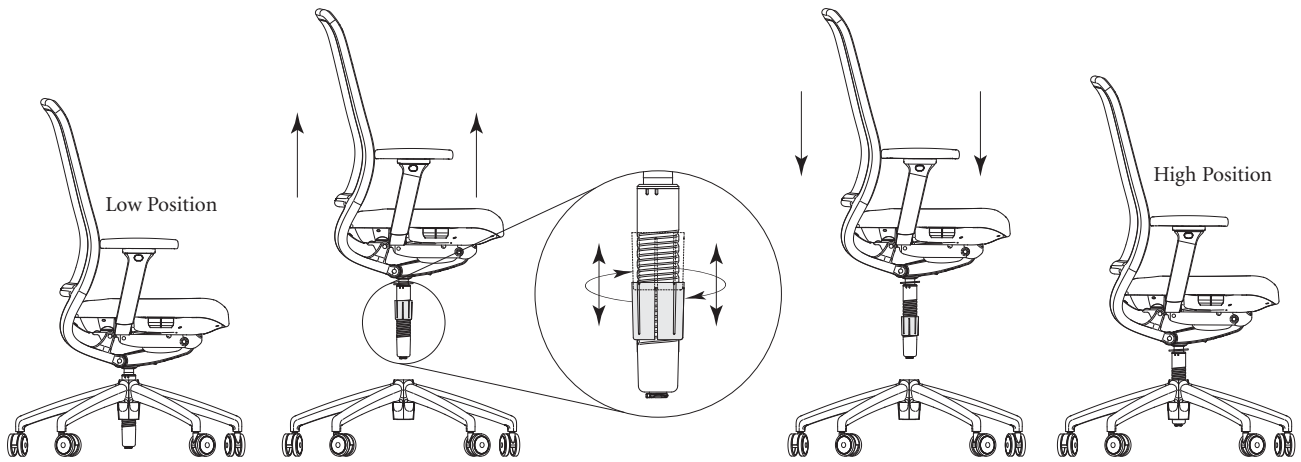

The Hero seat height can be additionally raised or lowered by manually rotating the plastic collar located on the cylinder. To get further adjustment on the seat height, follow the steps below.

Step 1

Remove Caster Base

Tools Required:

- Rubber Mallet

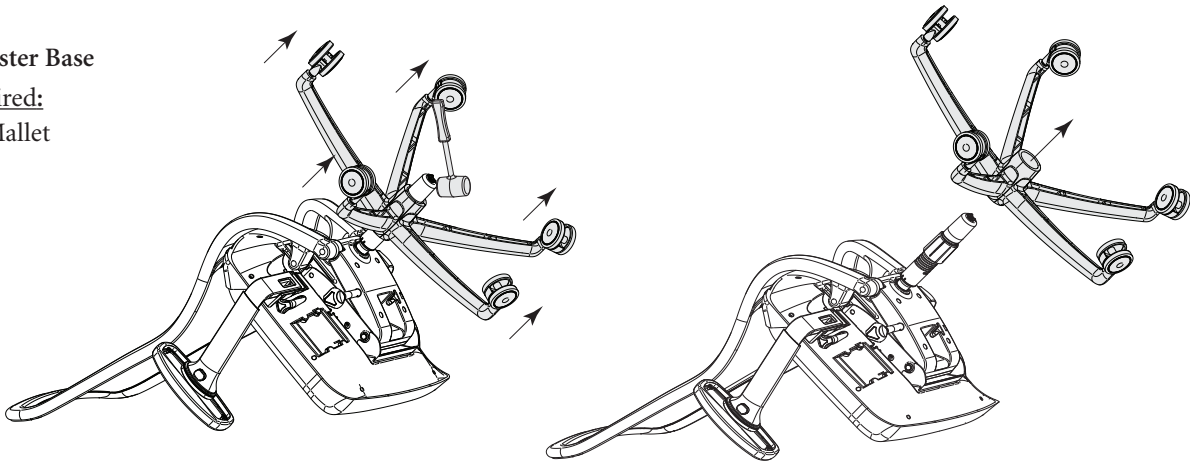

Step 2

Adjust Cylinder Collar

Tools Required:

- None

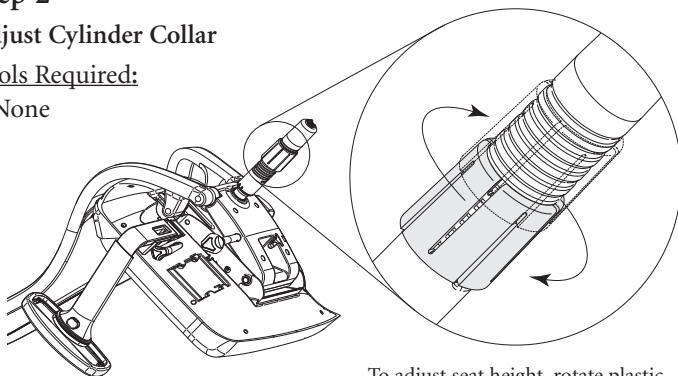

To adjust seat height, rotate plastic collar along threads on cylinder.

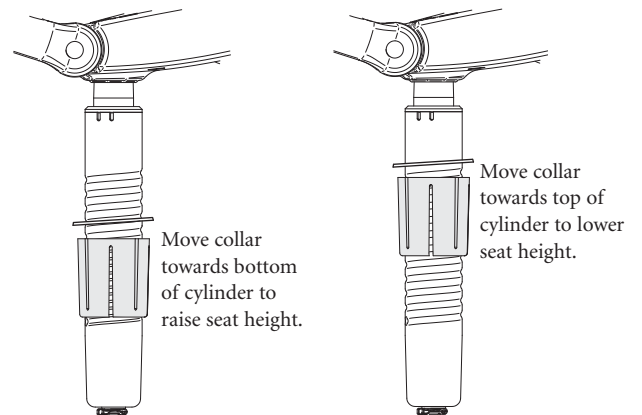

Move collar towards bottom of cylinder to raise seat height.

Move collar towards top of cylinder to lower seat height.

Proper product installation, in accordance with these instructions, is the responsibility of the installing agent. If you have any questions concerning these instructions, please call Kimball Office Customer Service.

Kimball[®]Office

Hero

Step 3

Reinstall Caster Base

Tools Required:

- None

