

Beo

Table Assembly

Tools Required

- Staple Gun
- Utility Knife
- Cordless Screw Driver
- Wrench - (for End Table model only)

Package Contents

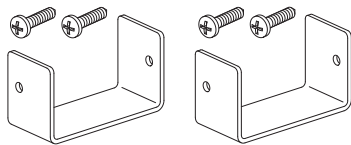

Ganging Bracket Bag Includes:
 2 - U-Brackets
 4 - #10 x 3/4" Panhead Screws
 (Number of bags included will depend on table model.)

End Table Installation

1. Place worksurface face down on clean, soft surface.
2. Remove legs from packaging and remove the nut and washer from the lag bolt on each leg.
3. Insert the lag bolt on each leg through the hole in one corner block on the worksurface/side rail. Secure leg to the table by using one washer and one nut per leg. Make sure the leg is perpendicular and flush to the side rails. Tighten the nut firmly by using wrench provided. (Figure A).
4. Position the chair to be ganged to table in the desired location. With angled shim on the table toward rear, position table so it rests on the side rail. Observe that table top is level to floor. If not, check that angled shims are toward rear of table. (Figure B).

Note: To attach table to chairs, see page 2.

Corner Table Installation

1. Place worksurface face down on clean, soft surface.
2. Remove legs from packaging and insert threaded end of one leg into the hole on the bottom of table. Turn leg clockwise until tightened. Repeat process for remaining leg. (Figure C).
3. Position chairs (to be ganged perpendicular to one another) facing inward and spaced apart so that the table will be able to rest on side rails of each chair, with legs of table aligned with back legs of chairs. Squeeze chairs inward toward table for tight fit. (Figure D).

Note: To attach table to chairs, see page 2.

Figure A

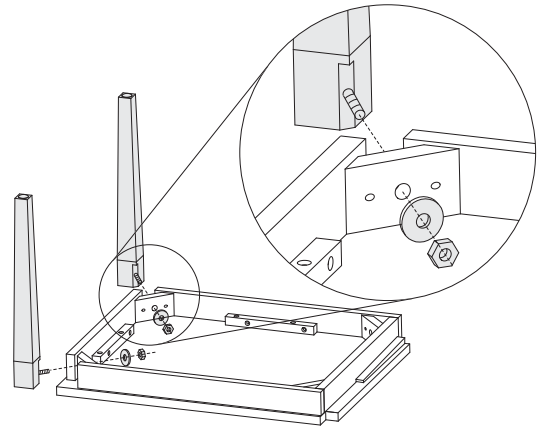

Figure B

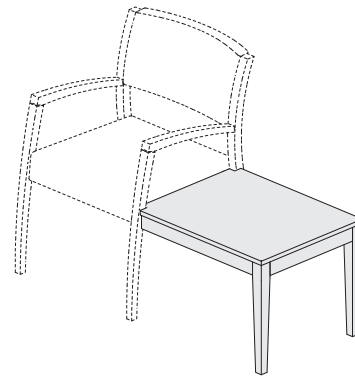

Figure C

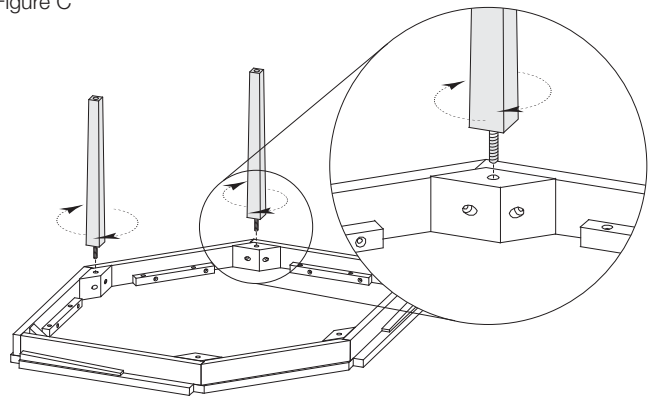
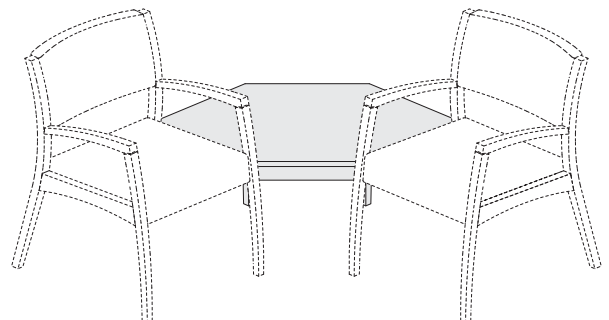

Figure D



Proper product installation, in accordance with these instructions, is the responsibility of the installing agent. If you have any questions concerning these instructions, please call Kimball Customer Service.

Kimball® Office

Beo

Gangng Tables

Description

Gangng brackets are used to secure end, inline, and corner tables to adjoining Beo seating. All three tables are gangng together using the same method. Use the following procedures to gangng any of the three tables.

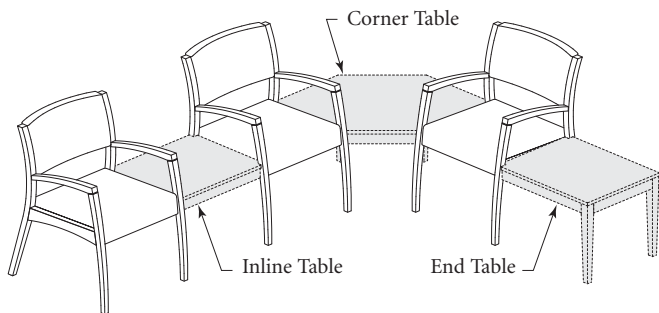

Installation

1. Position chairs & tables to be gangng in the desired location. With angled shims on the table toward rear, position table so it rests on the side rails. Squeeze chairs inward toward table for tight fit. Observe that table top is level to floor. If not, check that angled shims are toward rear of table. (Figure E).
2. On underside of chair, cut slit in black bottom fabric on side where gangng brackets are to be installed. (Figure F).
3. Place brackets over the side rails of both chair and table, one towards front of chair and one towards back. Using a cordless drill, insert two (2) #10 x 3/4" panhead screws into each bracket. (Figure G).
4. Staple bottom fabric back to side rail of chair. (Figure H).
5. If necessary, repeat Steps 2, 3, & 4 for opposite side of table.

Figure E

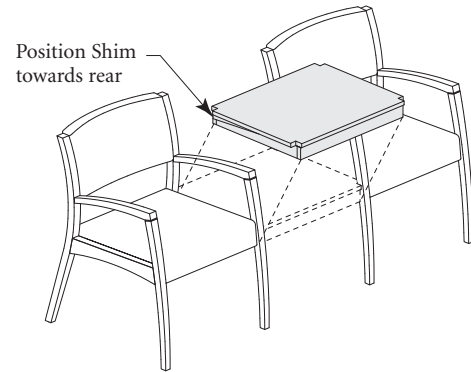

Figure F

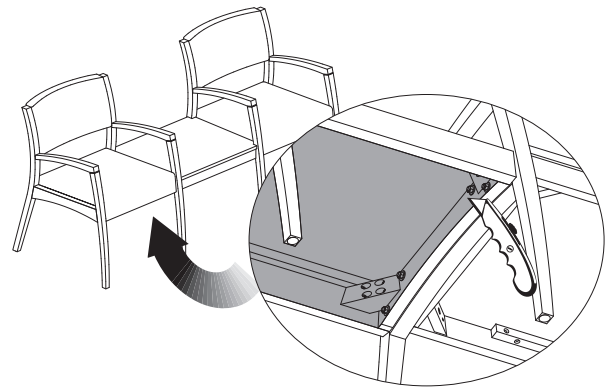

Figure G

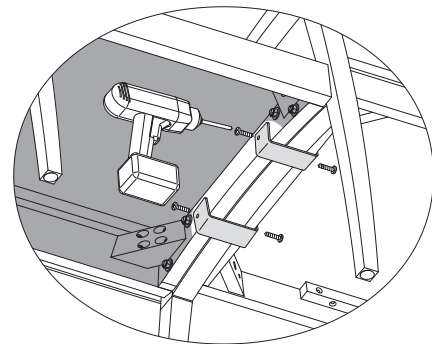

Figure H

