

Panel & Connector

Tools Required

- Tape Measure
- Level
- 7/16" Socket
- Ratchet
- 1/2" Open End Wrench
- Rubber Mallet
- Slot-headed Screwdriver

Note: The Cetra panel connection has been designed to be simple to install, yet structurally sound when properly assembled. In Figure A, the connection shown, panel-to-panel, will be typical of all top and bottom connections.

Installation

1. Determine position of panels per floor plan. Using a level, locate the high spot of the floor in area where panels are to be assembled. Panel assembly should start at a directional connector (L, T, X, V, Y, or Z).
2. Brackets are attached to panels by inserting the NAAB clamp into the "J" member. Using a 7/16" socket and ratchet, install a 1/4" x 20 nut onto stud of panel. (Figure B). If the panel face finishes differ, make sure the orientation and placement of bottom brackets is correct. Beginning with the first panel, install the bottom connector bracket for the starting position identified in Step 1. On the same panel, install the proper bracket for the next connection. (Figure C). **While tightening bottom brackets, pull them away from panel.** This allows proper clearance for the next "J" member to seat onto NAAB clamp. (Figure B). NAAB clamp tabs should rest against edge of "J" member. **Note:** Do not remove rubber band securing the alignment plate on panel-to-panel brackets until both panels are installed. Only the first panel will require two bottom brackets to be installed. All other panels will require only one bracket.

Figure A

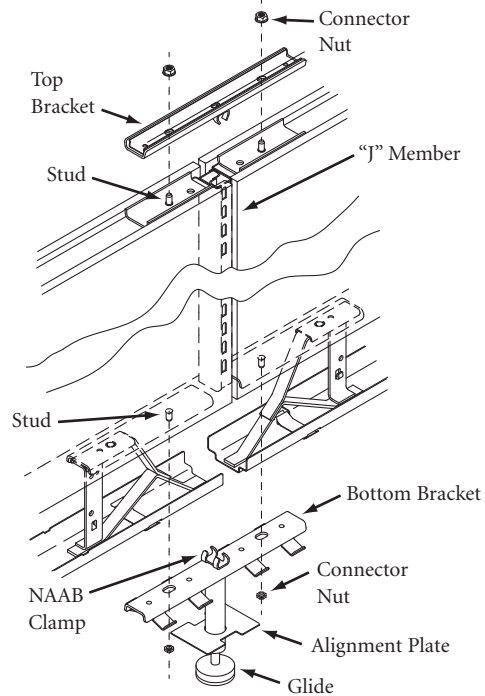

Figure B

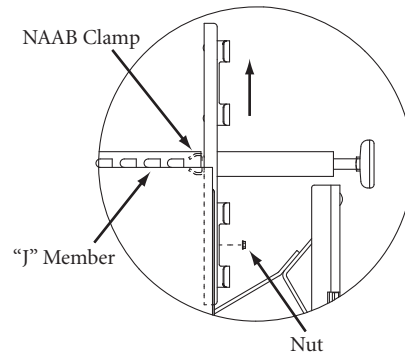
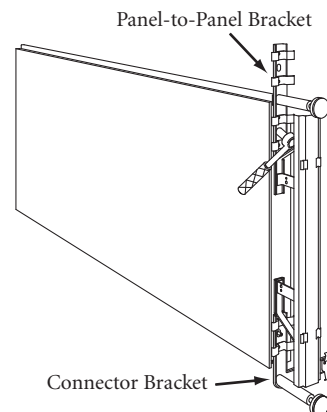

Figure C



Cetra

Installation (continued)

- On all panels to be used in conjunction with the connector identified in Step 1, install the appropriate bottom bracket required for the first connection.
- Assembly at connector locations should be done in panel, connector, panel sequence. With the rounded notches of the connector "J" member facing up, seat the connector post onto the corresponding connector bracket installed in Step 2. (Figure D). When assembled properly, the top of the connector and panel should align.

Note: Pull bracket out as far as possible to allow enough space for next "J" member to fully seat. (Figure E).

- Install the remaining panel(s) required at the connector by seating the panel's "J" member onto the NAAB clamp on the bottom connector bracket. (Figure F bottom).
- Seat the top cap bracket assembly onto top of panels and connector. Secure to panel studs using 1/4" x 20 nut(s). (Figure F top). Tighten by hand. To aid in seating of top cap bracket assembly, a rubber mallet may be used. Hold top cap firmly with hand to prevent top cap from working loose and strike metal portion of top cap bracket assembly. **NEVER** strike the top cap. Using 1/4" x 20 nut(s) secure bottom bracket to panel stud(s). Tighten nuts on top of panel fully.
- Note:** Make sure top cap bracket assembly is fully seated to allow for correct installation of panel top caps.
- After fully tightening each nut, level each assembled panel. Using 1/2" open end wrench or hand, turn glide(s) in required direction until panel is level. (Figure G).

Figure D

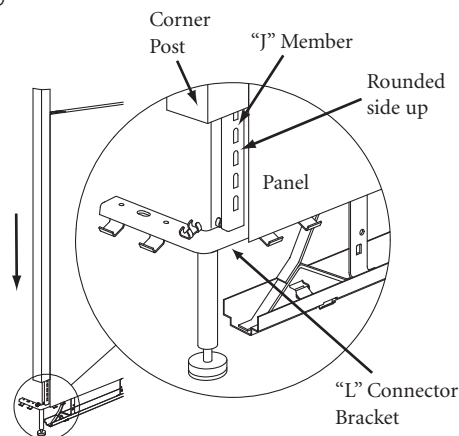

Figure E

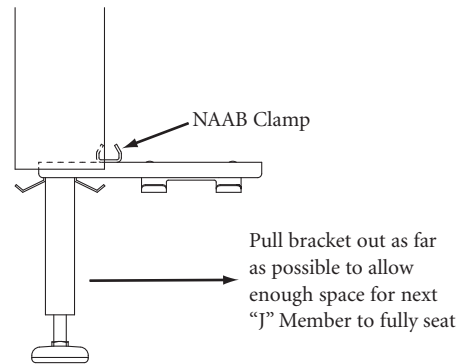

Figure F

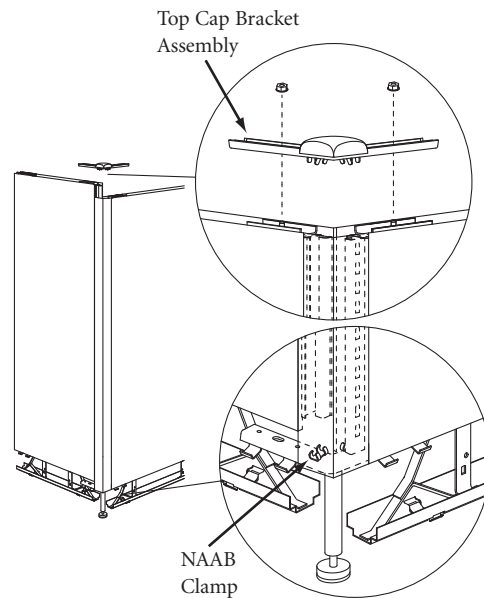
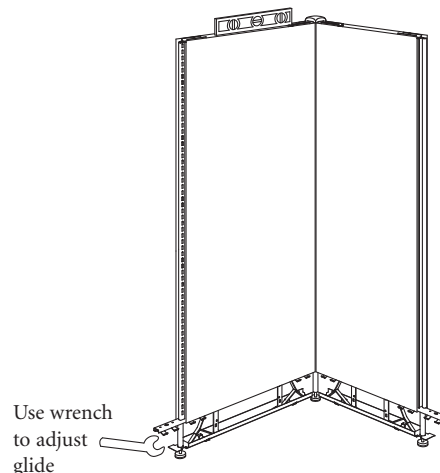

Figure G



Proper product installation, in accordance with these instructions, is the responsibility of the installing agent. If you have any questions concerning these instructions, please call Kimball Office Customer Service.

Kimball[®]Office

Cetra

Installation (continued)

8. To install end trim at the end of the panel run, check to make sure the bottom end bracket is fully extended away from the panel to allow the “J” member to drop. If not, loosen the existing ¼" x 20 nut on the bottom panel end bracket and pull the bracket away from the panel and reinstall ¼" x 20 nut. (Figure H).
9. Slide the end trim down until seated. The end trim may not fully seat due to the tighter fit of the spacer block. (Figure I).
10. Install NAAB clamp from the top end bracket into the top of the “J” member of the end trim. The top end bracket may not fully seat due to the tighter fit of the new spacer blocks. If not, tap on the top end bracket with a rubber mallet until the bracket and end trim is fully seated. (Figure J). Do not strike the wood end trim, as it may crack.
11. Secure the end trim by reinstalling the top end bracket with the ¼" x 20 nut. Align top cap and push down into place. (Figure K).

Figure H

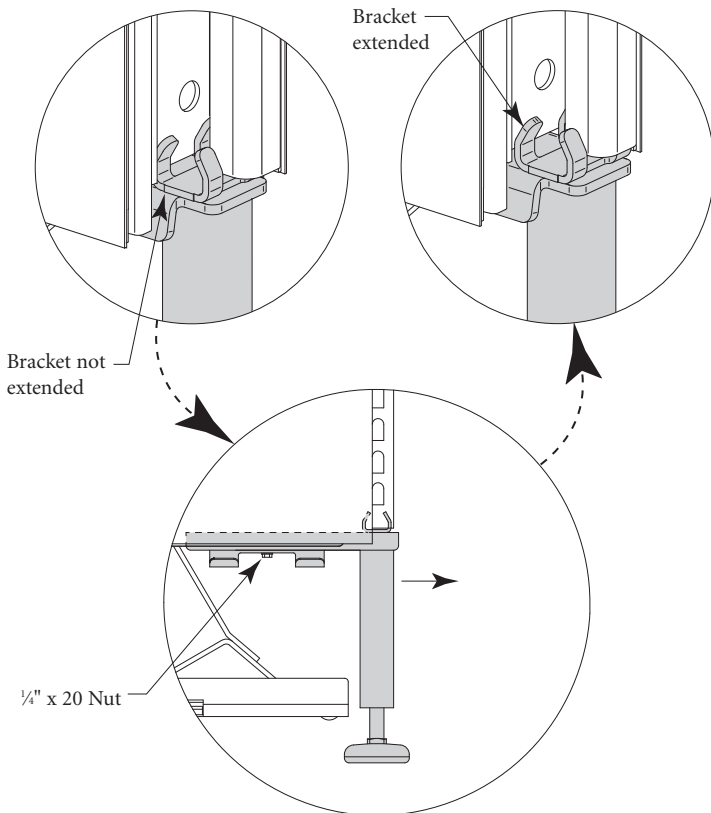

Figure I

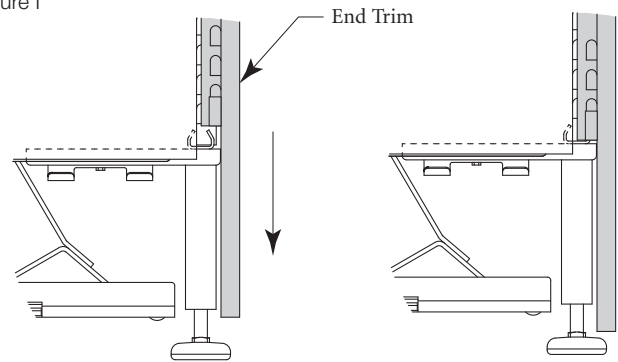

Figure J

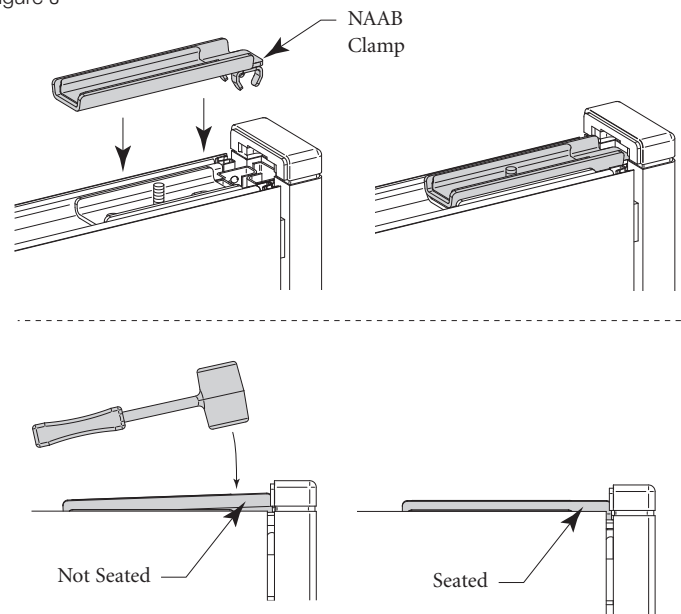
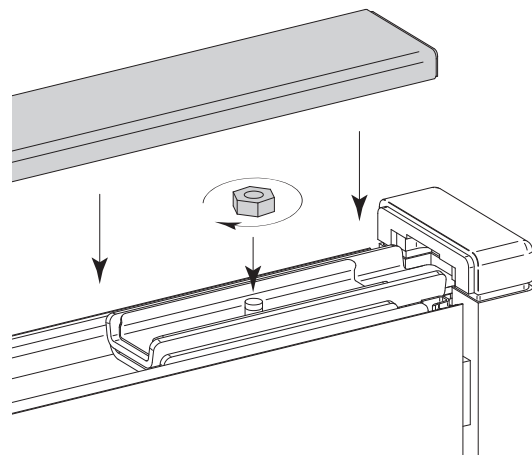

Figure K



Printed in U.S.A. © 2009 Kimball International, Inc. T 800.482.1818 F 812.482.8300

Proper product installation, in accordance with these instructions, is the responsibility of the installing agent. If you have any questions concerning these instructions, please call Kimball Office Customer Service.

Kimball[®]Office