

Transaction Counter on Cetra Panels

Tools Required

- Drill with torque option
- Tape measure
- #R 2 square screwdriver bit
- Level

Installation

Note: Transaction counters need to be installed prior to any worksurface installation directly beneath them, especially when used with lower panel heights. This is required so that there is room to use a power drill between the bottom of the transaction counter and the lower worksurface.

1. Locate position where transaction counter will be installed on the panel. Insert top hook on top of transaction bracket into the “J” member slot at a 45 degree angle (Figure A)
2. Push the top of the transaction counter bracket downward (Figure B). Insert one left and one right handed transaction counter bracket in selected “J” member for each transaction counter. Wider transaction counters will include an additional right hand bracket to be placed in a “J” member near the center for support (Figure C).
3. Lay the transaction counter on top of the transaction counter brackets and align with panels as needed (Figure D).
4. Attach the transaction counter to the brackets with screws provided. Three screws are required per bracket.

Figure A

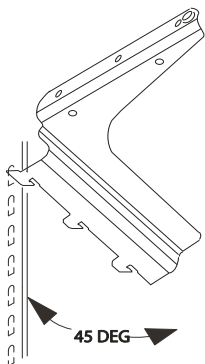

Figure B

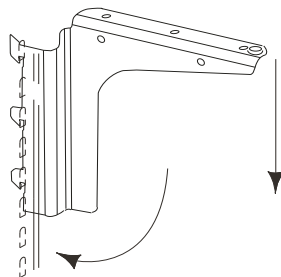

Figure C

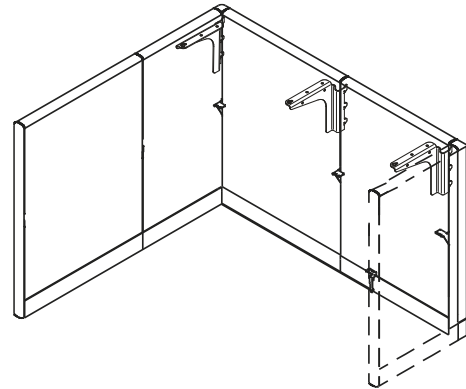

Figure D

