

Inspect Mid-Wireway determining where each post cover will be used. Also determine the best direction of insertion when using the "L" covers. If the application allows attachment to only one side, reference examples of post covers and splice plate in (Figure A).

Figure A

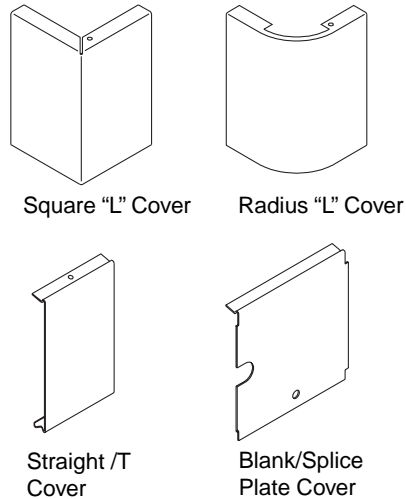

"L" Connector Cover Assembly:

1

Remove protective layer from adhesive strips on back of post cover (Figure B). Square "L" cover shown.

Figure B

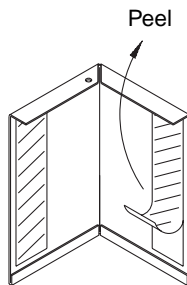

2

Attach splice plates to the flat areas on the back of the post cover. Attach no more than 2 1/4" of the splice plate to the Square "L" cover, or 1 1/4" of the splice plate to the Radius "L" cover (Figure C). Ensure the paint hole is not located in reveal between the panel.

Figure C

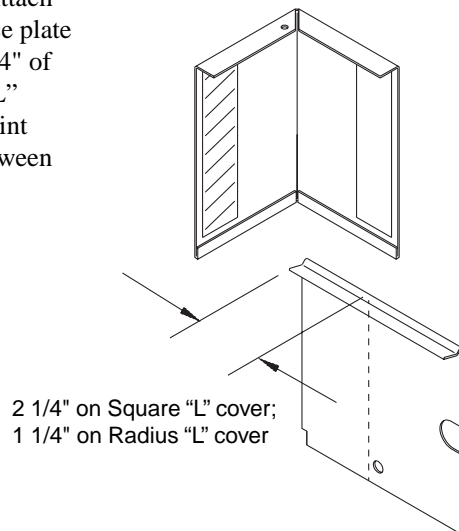

Cetra®
 Assembly Instructions
**Mid-Wireway
 Connector Cover**

Recommended Tools
 • None

Package Contents	Qty.
• Square, Radius, or Straight and "T" Connector Covers	per order



Telephone 800.482.1818
 Fax 812.482.8300
www.furniture.kimball.com

Form #AICEC0003D-00
 #1429783

Printed in U.S.A.
 © 1999 Kimball International, Inc.

Proper product installation, in accordance with these instructions, is the responsibility of the installing agent. If you have any questions concerning these instructions, please call your Kimball Customer Care Team.

Cetra®

Assembly Instructions

**Mid-Wireway
Connector Cover**

Note: Carefully align the splice plate top edge to the underside top edge of the post cover. **PRESS FIRMLY TOGETHER** (Figure D).

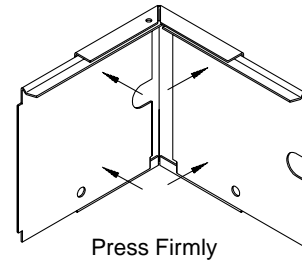
Figure D**3**

Slide splice plate into wireway cover top and bottom grooves (Figure E).

Note: If post covers are not properly installed, the wireway will not be properly aligned.

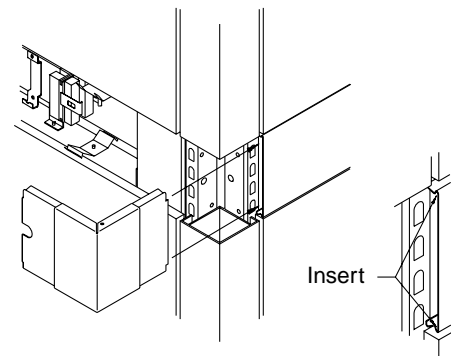
Figure E**4**

Begin by sliding the adjacent wireway cover into the bottom of the splice plate. Snap cover into bottom retaining clip. Close top of cover into top retaining brackets (Figure F).

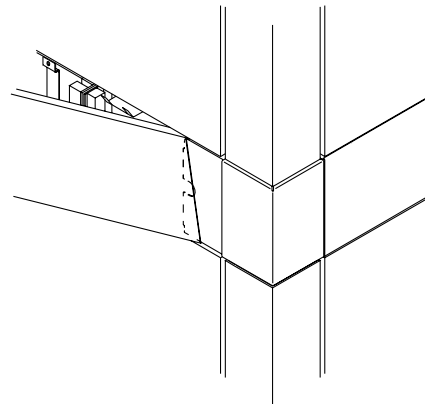
Figure F

Cetra®

Assembly Instructions

**Mid-Wireway
Connector Cover****Straight and "T" Connector Cover Assembly:****1**

Attach splice plate to the flat area on the back of the post cover, centering the cover in the un-notched area of the splice plate (Figure G).

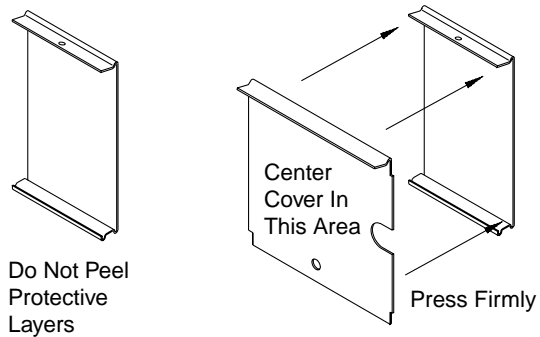
Figure G

Note: When installing the Splice Plate, insert the bottom edge first, then rotate the top edge in and snap it into place. Ensure the cover is off-set and away from the notch on the splice plate. The notch should not be visible when the cover is installed on the wireway (Figure H). **PRESS FIRMLY TOGETHER.**

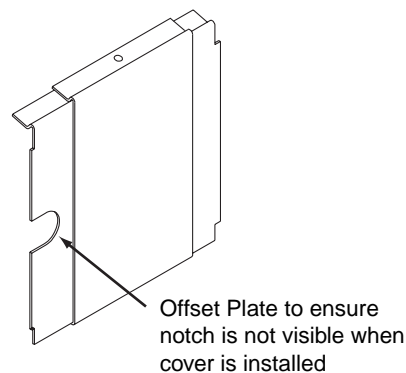
Figure H**2**

Splice Plate/Cover installation is easiest when attached to both adjoining mid-wireway covers simultaneously. Loosen top edges of wireway covers and allow them to hinge downward (Figure I).

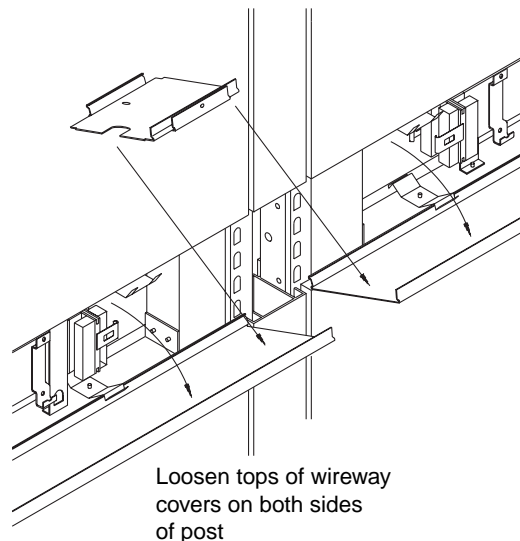
Figure I

Proper product installation, in accordance with these instructions, is the responsibility of the installing agent. If you have any questions concerning these instructions, please call your Kimball Customer Care Team.

Cetra®

Assembly Instructions

**Mid-Wireway
Connector Cover****3**

Snap post cover into position between wireway covers. **PRESS FIRMLY** and make sure all edges engage. Ensure notch in splice plate will not be visible from front of cover (Figures I and J).

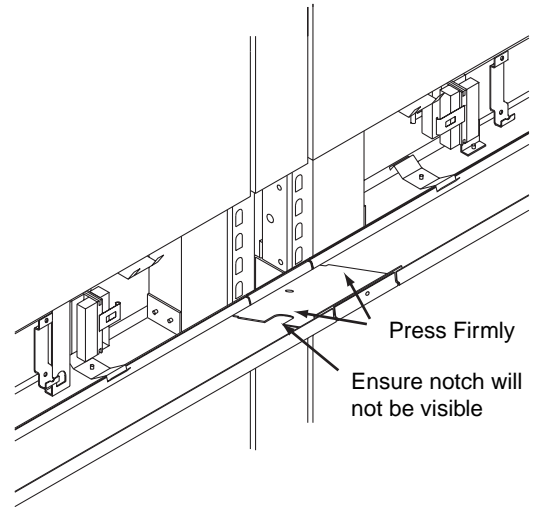
Figure J**4**

Hinge covers upward and snap into position on wireway. Check alignment of all covers and adjust if necessary (Figure K).

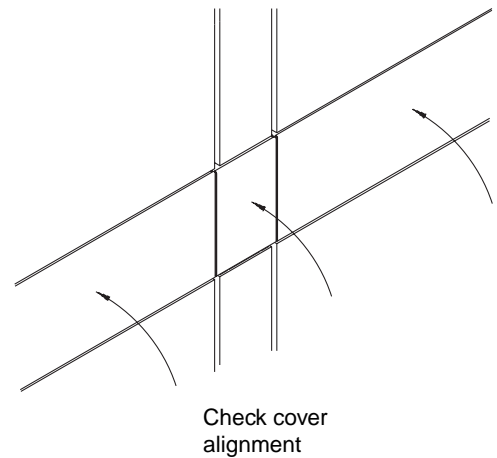
Figure K

Inspect Mid-Wireway determining where each post cover will be used. Also determine the best direction of insertion when using the "L" covers. If the application allows attachment to only one side, reference examples of post covers and splice plate in (Figure A).

Figure A

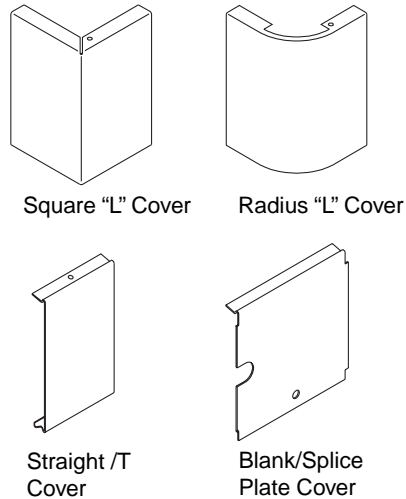

"L" Connector Cover Assembly:

1

Remove protective layer from adhesive strips on back of post cover (Figure B). Square "L" cover shown.

Figure B

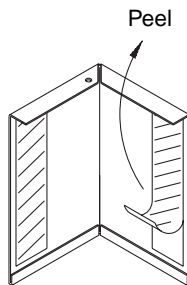

2

Attach splice plates to the flat areas on the back of the post cover. Attach no more than 2 1/4" of the splice plate to the Square "L" cover, or 1 1/4" of the splice plate to the Radius "L" cover (Figure C). Ensure the paint hole is not located in reveal between the panel.

Figure C

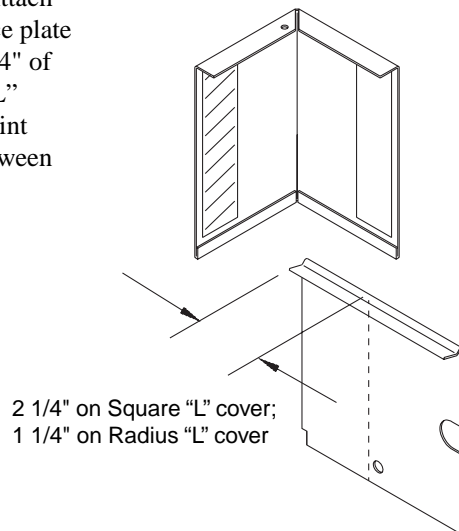

Cetra®
 Assembly Instructions
**Mid-Wireway
 Connector Cover**

Recommended Tools
 • None

Package Contents	Qty.
• Square, Radius, or Straight and "T" Connector Covers	per order



Telephone 800.482.1818
 Fax 812.482.8300
www.furniture.kimball.com

Form #AICEC0003D-00
 #1429783

Printed in U.S.A.
 © 1999 Kimball International, Inc.

Proper product installation, in accordance with these instructions, is the responsibility of the installing agent. If you have any questions concerning these instructions, please call your Kimball Customer Care Team.