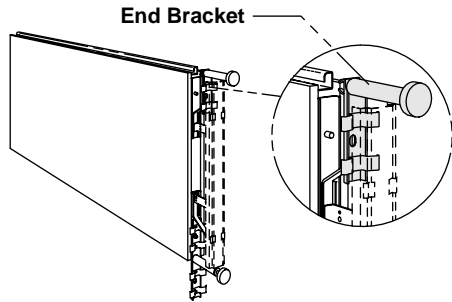
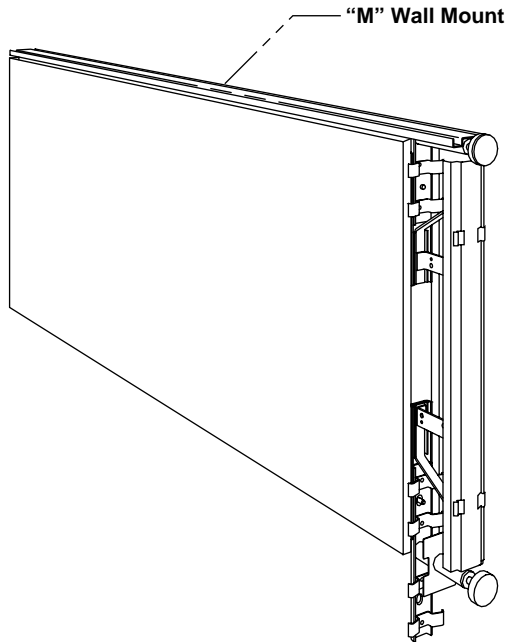

Figure A



1 Attach bottom end bracket to correct panel using the panel assembly instructions (Form #AISYCE001) (Figure A).

Figure B



2 Attach wall mount connector to first panel in run (Figure B).

Figure C

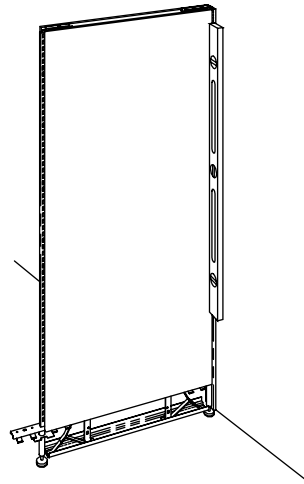
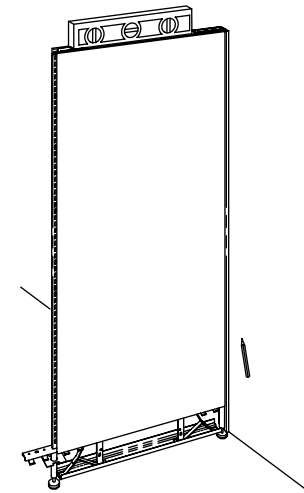

Figure D



3 Position panel and connector at correct starting point. Level the panel and wall mount on either side of wall mount. Also level top of panel. A shim may be required to make wall mount plumb with the wall. When attaching a wall mount next to TRAXX®, level top of wall mount with top of Traxx if possible. Mark the location of wall mount (Figures C & D).

Cetra®

Assembly Instructions

“M” Wall Mount Installation

Recommended Tools

- Level (4 ft. or greater)
- Variable Speed Drill
- Drill Bits
- Tape Measure
- Additional tools may be required depending on type of fastener.

See other side for additional steps.

Proper product installation, in accordance with these instructions, is the responsibility of the installing agent. If you have any questions concerning these instructions, please call Kimball Customer Service.



Telephone 800.482.1818
 Fax 812.482.8300
www.furniture.kimball.com

Form #AISYCE002A-98
 #1181229

Printed in U.S.A.
 © 1998 Kimball International, Inc.

Cetra®

Assembly Instructions

“M” Wall Mount Installation

- 4** Determine wall construction and anchoring method for proper load support. Select the appropriate fasteners for type of structural wall.

Notice:

It is the responsibility of the installer and/or the contractor to select and install the proper fasteners in the structural wall. Kimball International does not furnish fasteners or assume liability for their use.

Figure E

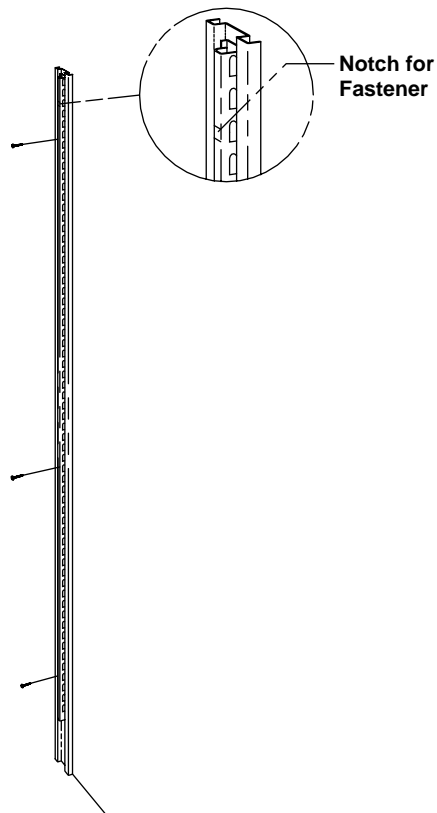

- 5** Secure connector to wall with a minimum of two fasteners. Prepare wall for the wall mount attachment by pre-drilling for and/or installing fasteners per manufacturer's guidelines. Prepare wall mount for attachment by drilling a hole through the wall mount on the “J” member side (Figure E).

- 6** Attach wall mount to wall using appropriate fasteners.

- 7** Turn panel glide inward. Slide the panel so the NAAB clamp fits under the “J” member of the wall mount.

Figure F

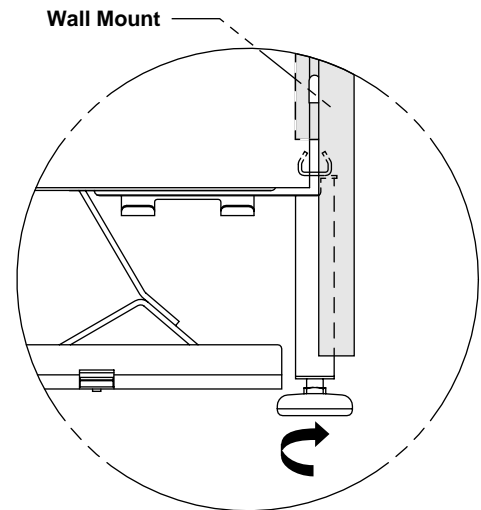

- 8** Use 1/2" open end wrench or hand to turn glide until panel is level and fully seated (Figure F).

- 9** To ensure a tight fit for the connector top cap additional foam blinder strips may need to be applied (Figure G).

Figure G

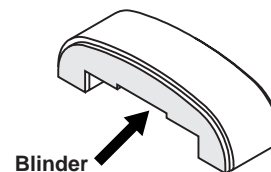

Proper product installation, in accordance with these instructions, is the responsibility of the installing agent. If you have any questions concerning these instructions, please call Kimball Customer Service.