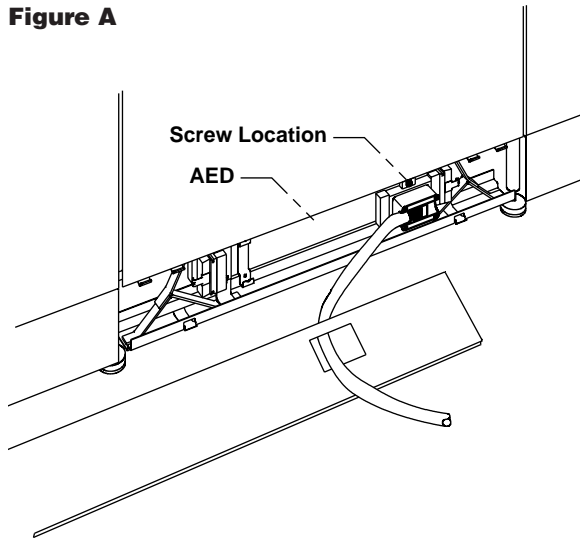

Figure A



Note:

Power entry connections must be made by a licensed electrician only. Installation must be in accordance with the National Electrical Code and Local Codes. See the following pages for eight-wire wiring schematic instructions for circuit connection options.

1

Locate floor power entry according to electrical plan. Insert floor power entry (AEF1U) into receptable location on either side of the power distribution assembly (AED) and secure with two #10 x 5/8" screws (Figure A).

Floor power entry will plug into either side of the power distribution assembly (AED). Cord direction can be changed by rotating the cord (Figure B).

2

Extend power cable through wireway cover. This must be done before the power connections are made to building supply (Figure A).

Figure B

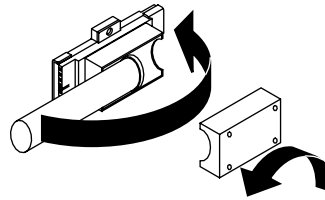

Figure C

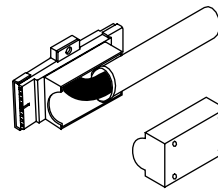
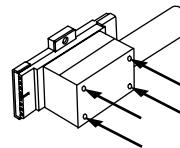

Figure D



3

Secure wireway cover to panel. Rotate floor power entry cord, if necessary (Figure B). Install floor power entry cover and four screws (Figure C & D).

4

Connect power leads to building branch circuit according to wiring schematic installation sheets.

Warning:

Do not interconnect panels powered from different feed units. This can cause shock and fire hazard.

This panel system may be connected to more than one source of supply. All sources must be disconnected prior to any servicing. No single circuit may be powered by more than one source.

Cetra®

Assembly Instructions

**Standard
8-Wire Floor
Power Entry
Installation
(AEF1U)**

Recommended Tools

Phillips Screwdriver

**Package
Contents**

	Qty.
Floor Power Entry Assembly (AEF1U)	1
Phillips Head #10 X 5/8"	2
Thread Forming Screws	
Power Entry Cover	1
Phillips Head #6 X 1 1/4"	4
Shoulder Screws	



Telephone 800.482.1818
Fax 812.482.8300

Form #AISYCE005B-96
#1133799

Printed in U.S.A.
© Kimball International, Inc. 1995

Proper product installation, in accordance with these instructions, is the responsibility of the installing agent. If you have any questions concerning these instructions, please call Kimball Customer Service.

Cetra®

Assembly Instructions

Standard 8-Wire Schematic 2 & 2 Configuration and 1 & 2 Configuration

2 & 2 CONFIGURATION

Receptacles 1, 2, 4, and 5

1 & 2 CONFIGURATION

Receptacles 1, 4, and 5

Note:

Receptacle number 3 can not be used in these configurations.

The Cetra standard eight-wire electrical system provides up to four circuits using four hot wires, two increased size neutrals, a system ground and an isolated ground for circuits four and five.

Ideally, a four-wire, WYE, 208 volt service provides the best utilization. Circuits 1 & 2 can be wired for general use. Circuits 4 & 5 can be reserved for data and communications requirements.

Other power supplies such as 120/240 volt delta, 120/240 volt open delta and 120/240 volt single phase will use circuits 1,4 and 5 with L2 (red) circuit taped off.

Single phase 120 volt, two-wire systems will use L1 (black) paired with N1 (white/black) and L4 (pink) paired with N2 (white/red). L2 (red) and L5 (blue) should not be used.

2 & 2 Configuration

120/208V WYE 3 Phase 4 Wire
4 Circuit, 20 AMP, Isolated Ground

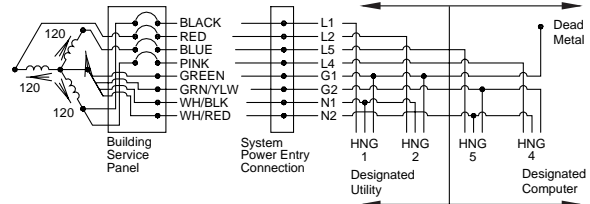

1 & 2 Configuration

120/240V Delta Single Phase
3 Circuit, 20 AMP, Isolated Ground

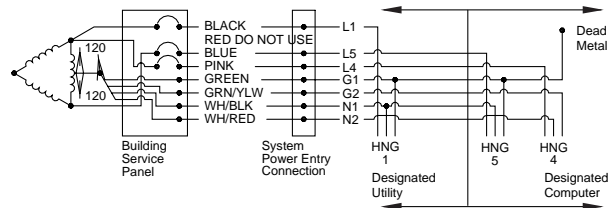

1 & 2 Configuration

120/240V Open Delta Single Phase
3 Circuit, 20 AMP, Isolated Ground

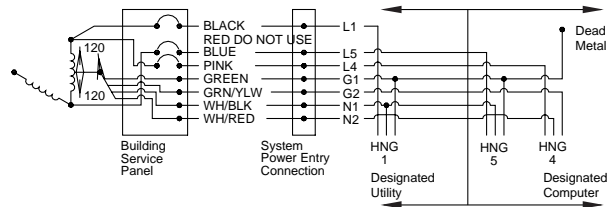

1 & 2 Configuration

120/240V Single Phase
3 Circuit, 20 AMP, Isolated Ground

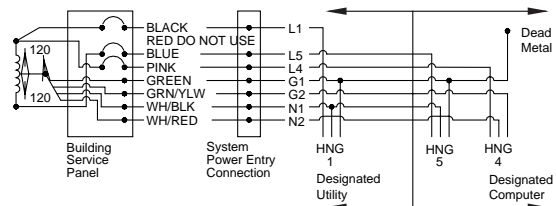

Proper product installation, in accordance with these instructions, is the responsibility of the installing agent. If you have any questions concerning these instructions, please call Kimball Customer Service.

3 & 1 CONFIGURATION

Receptacles 1, 2, 3, and 4

2 & 1 CONFIGURATION

Receptacles 1, 3 and 4

Note:

Receptacle number 5 can not be used in these configurations.

The Cetra standard eight-wire electrical system provides up to four circuits using four hot wires, two increased size neutrals, a system ground and an isolated ground for the fourth circuit.

Ideally, a four-wire, WYE, 208 volt service provides the best utilization. Circuits 1, 2, and 3 can be wired for general use. Circuit 4 which has its own increased size neutral and an isolated ground, can be reserved for data and communications requirements.

Other power supplies such as 120/240 volt delta, 120/240 volt open delta and 120/240 volt single phase will use circuits 1, 3 and 4 with L2 (red) circuit taped off.

Single phase 120 volt, two-wire systems will use L1 (black) paired with N1 (white/black) and L4 (pink) paired with N2 (white/red). L2 (red) and L3 (blue) should not be used.

3 & 1 Configuration

120/208V WYE 3 Phase 4 Wire
4 Circuit, 20 AMP, Isolated Ground

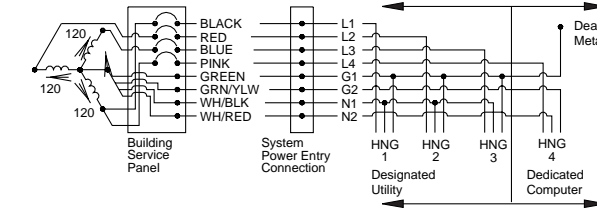

2 & 1 Configuration

120/240V Delta Single Phase
3 Circuit, 20 AMP, Isolated Ground

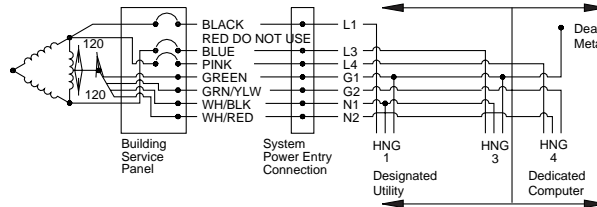

2 & 1 Configuration

120/240V Open Delta Single Phase
3 Circuit, 20 AMP, Isolated Ground

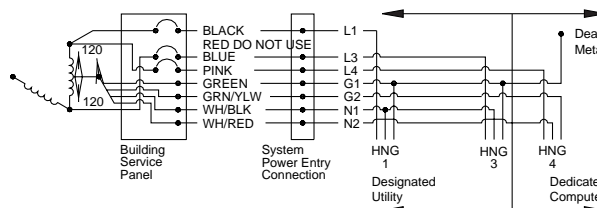

2 & 1 Configuration

120/240V Single Phase
3 Circuit, 20 AMP, Isolated Ground

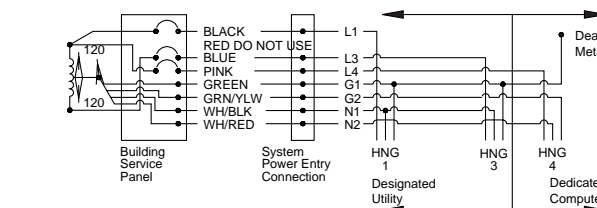

Cetra®

Assembly Instructions

**Standard
8-Wire
Schematic
3 & 1
Configuration
and 2 & 1
Configuration**

Proper product installation, in accordance with these instructions, is the responsibility of the installing agent. If you have any questions concerning these instructions, please call Kimball Customer Service.