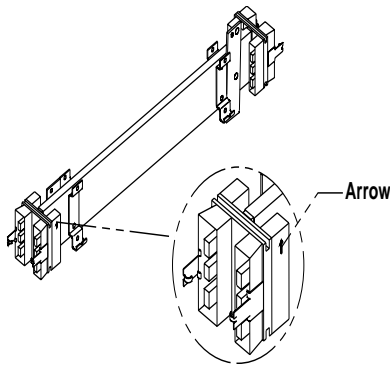
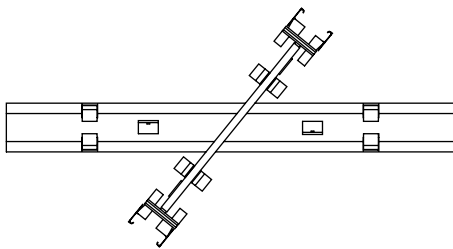

Figure A



- 1** Position the power distribution assembly with receptacle securing lip at bottom (Figure A).

Figure B



- 2** Position power distribution assembly as shown in (Figure B). Turn ends of distribution inwards towards wireway trough.

Figure C

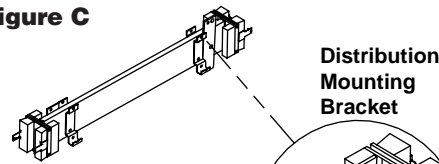
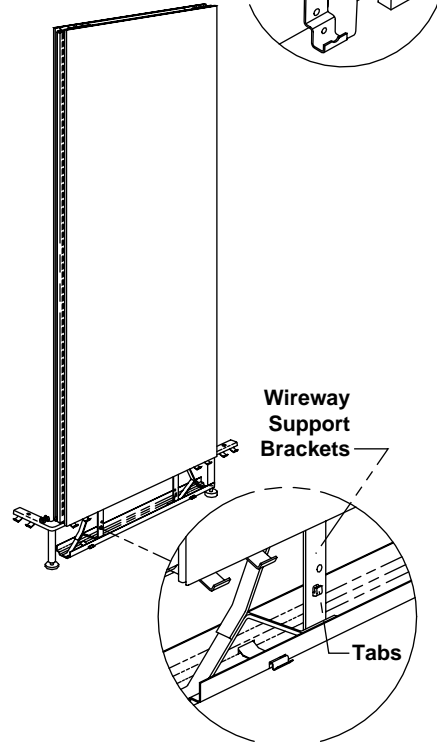
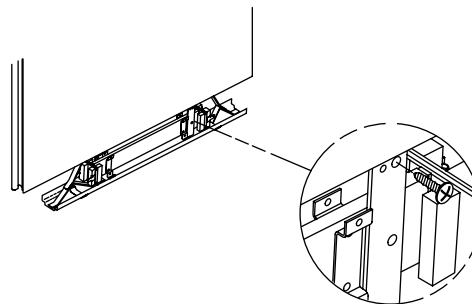

Figure D



- 3** Hook bottom of the distribution assembly mounting brackets into the tabs on the wireway support brackets (Figures C & D).

Figure E



- 4** Secure distribution assembly using the screws provided. Screws may be installed from either side of panel (Figure E). Two screws are required per power distribution.

Cetra®

Assembly Instructions

Power Distribution Assembly Installation (AED)

Recommended Tools
Screwdriver

Package Contents	Qty.
Power Distribution Assembly (AED)	Varies
Phillips Head #10 X 5/8" 4 per Thread Forming Screw	AED



Telephone 800.482.1818
Fax 812.482.8300

Form #AISYCE007-96
#1183767

Printed in U.S.A.
© Kimball International, Inc. 1995

Proper product installation, in accordance with these instructions, is the responsibility of the installing agent. If you have any questions concerning these instructions, please call Kimball Customer Service.