

Figure A

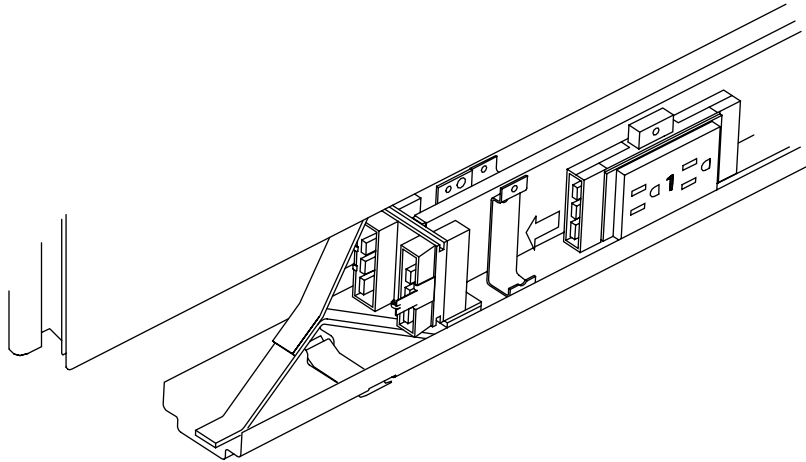
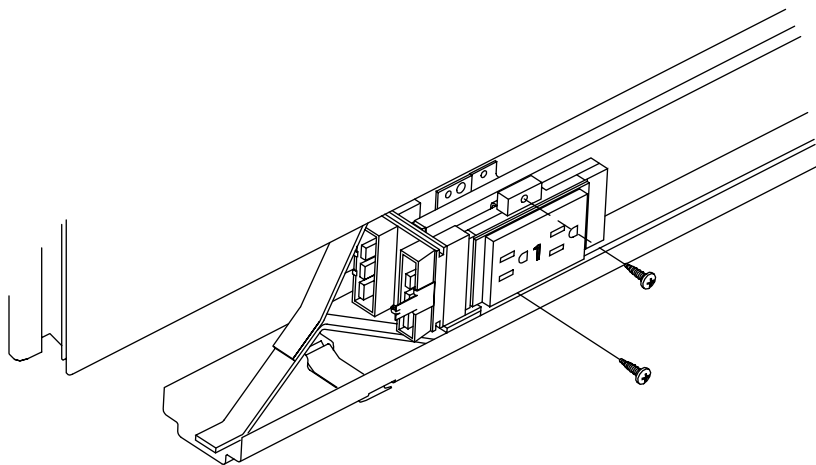

Figure B



Note: Installation must be in accordance with the National Electrical Code and local codes.

1

Choose the appropriate Receptacle number in accordance with your installation layout.

2

Slide the Receptacle into the power distribution assembly until fully engaged (Figure A).

3

Secure the Receptacle with the screws provided. Make sure the Receptacle is installed straight to ensure a clean look when wireway cover is installed (Figure B).

Kimball

Assembly Instructions

Receptacle Installation (AER)

Recommended Tools
Phillips Screwdriver or
Screw Gun

Package Contents	Qty.
Receptacle(s)	Varies
#10 x 5/8" Phillips Head Thread Forming Screw(s)	2 per



Telephone 800.482.1818
Fax 812.482.8300
www.furniture.kimball.com

Form #AISYCE010A-99
#1181233

Printed in U.S.A.
© 1995 Kimball International, Inc.

Proper product installation, in accordance with these instructions, is the responsibility of the installing agent. If you have any questions concerning these instructions, please call your Kimball Customer Care Team.