

# Universal LED Lighting

## Single Power LED Task Light

### Tools Required

- Cordless Drill
- 3/32" Drill Bit
- #2 Phillips Screwdriver Bit

### Hardware Required

- (2) #8 X 1/2" Pan Head Phillips Screws per light fixture (for installation on non metal surface only)
- (2) Adhesive backed plastic wire clips

### Installation

For Magnet Mount: (under metal surface)

1. Position light fixture under the metal cabinet surface where desired until magnets engage. Magnets are concealed inside the fixture.
2. Adjust the fixture location by sliding the fixture side to side and front to back as needed. (Figure A).
3. Plug the end of the power supply into either end of the light fixture. (Figure D).
4. Route the cords and install adhesive backed wire clips as needed to hold the cords in the proper locations.
5. Plug the power supply into a receptacle.

For Non Metal Mount: (wood surface)

1. Determine the approximate location for mounting the light fixture under the wood cabinet and make two centerline marks at the following distances apart:  
 16" light fixture Dimension "A" = 3 1/2"  
 25" light fixture Dimension "A" = 19"  
 30" light fixture Dimension "A" = 25"
2. Drill a 3/32" diameter by 1/2" deep hole at each centerline location. (Figure B).
3. Install a screw in each hole until there is approximately 1/16" relief between the head of the screw and the wood cabinet surface.
4. Locate the light fixture over the head of the screws and slide the light fixture to engage the screws in the key slot on the light fixture. (Figure C).
5. Plug the end of the power supply into either end of the light fixture. (Figure D).
6. Route the cords and install adhesive backed wire clips as needed to hold the cords in the proper locations.
7. Plug the power supply into a receptacle.

Figure A

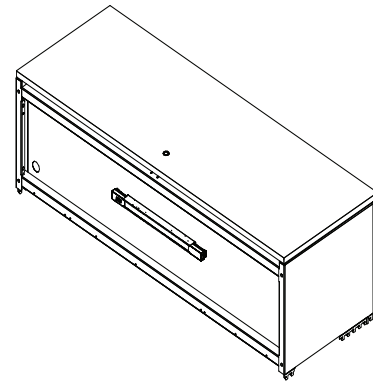

Figure B

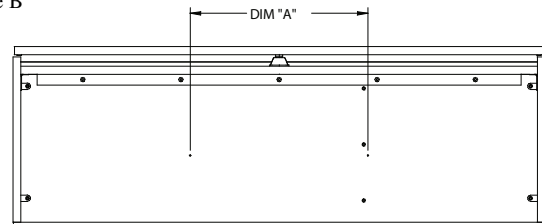

Figure C

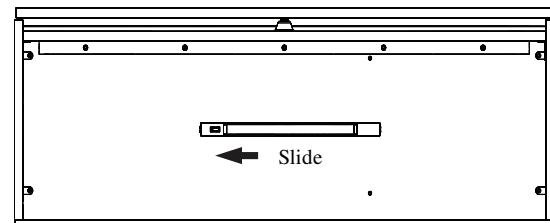
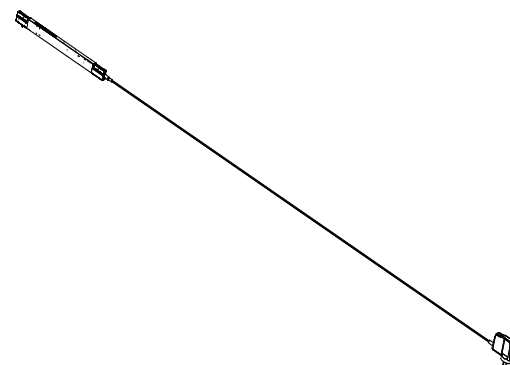

Figure D



Proper product installation, in accordance with these instructions, is the responsibility of the installing agent. If you have any questions concerning these instructions, please call Kimball Office Customer Care.

Kimball<sup>®</sup>Office