

# Interworks® EQ

## Sectional Panel Tiles, Top Cap and Wireway Cover

Tools Required  
Level, Screw Gun

### Installation

Tile instructions apply to sectional panels. Two people are recommended, start installation with bottom tiles and work upwards. Communication hardware and receptacles must be installed.

Top cap and base wireway instructions apply to tackable acoustical, glass and sectional panels.

To remove tiles, reverse step order.

### Step 1

#### Install Sectional Tiles

- Start with bottom tiles and work up
- Insert top edge of tile into upper “J” channel on frame
- Rotate bottom of tile flat against panel frame
- Slide tile downward until completely seated in lower “J” channel

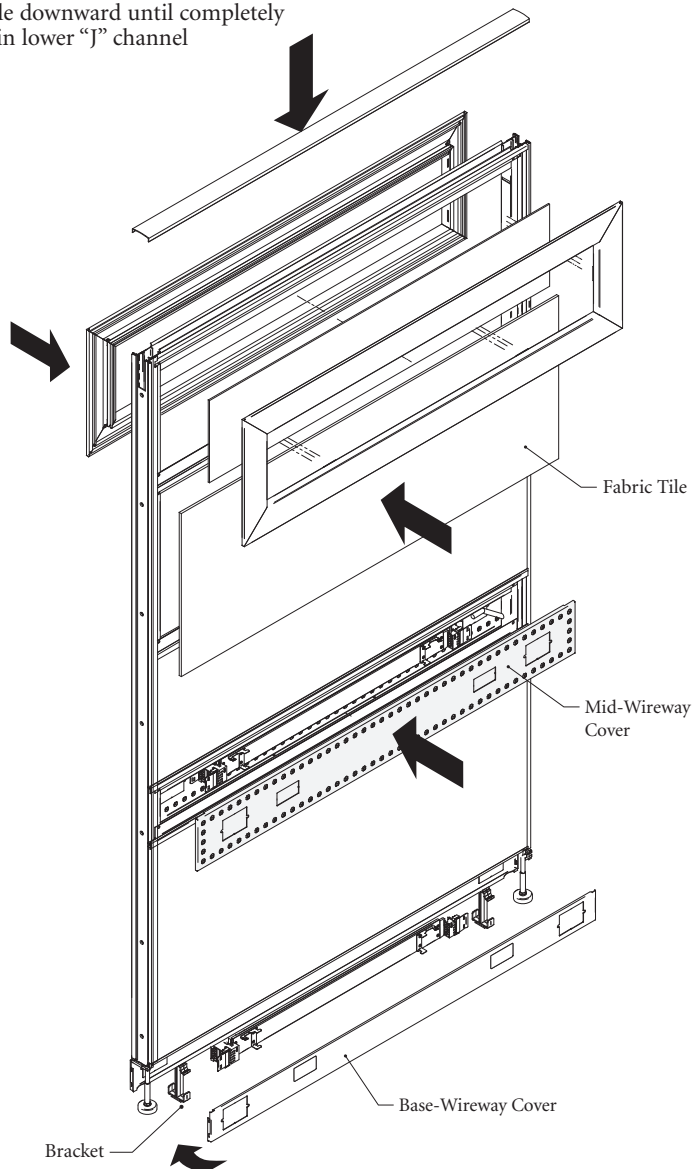

### Step 2

#### Glass Tiles

- Tile half with glass: insert top edge into top “J” channel
- Insert retention clip (one per vertical edge) between glass frame and panel vertical, rotate, fasten with screw (provided)
- Tile without glass: Same as Step 1

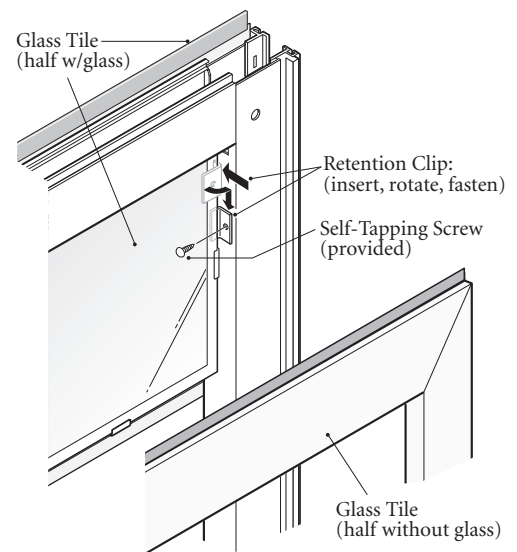

### Step 3

#### Install Top Cap and Connector

- Insert connectors at panel-to-panel connections
- Install top caps

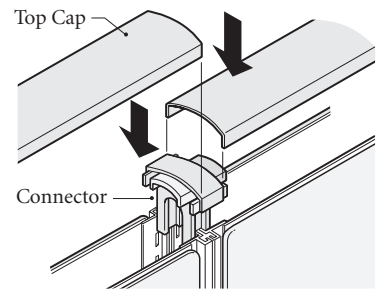

### Step 4

#### Base-Wireway Cover

- Engage slot in wireway cover to bottom of bracket
- Lift up on wireway cover and press up over top of bracket

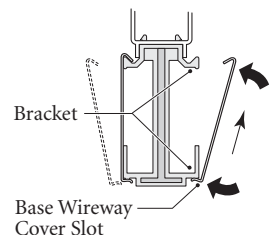

Proper product installation, in accordance with these instructions, is the responsibility of the installing agent. If you have any questions concerning these instructions, please call Kimball Office Customer Service.

Kimball Office