TRAXX and Tiles® Assembly Instructions

1008769 Revision A-11
Complete Series Master Packet

Proper product installation, in accordance with these instructions, is the responsibility of the installing agent.
If you have any questions concerning these instructions, please call Kimball Office Customer Service.

Traxx[®] and Tiles

Traxx Installation

Tools Required

- Level (4 ft. or greater)
- Chalk Line
- Nylon String
- Variable Speed Drill with Torque Option
- Electric Miter Saw
- Drill Bits
- Tape Measure

Package Contents

- Traxx
- Splice Plates (4 per each set of Traxx)
- (8) #6 x 3/8" Panhead Screws

Installation

1. Locate high spot of floor using level or transit. Keep in mind any panel run, worksurface, or storage that may be affected by Traxx location.
2. Mark 28 1/2" height dimension on the wall at the high spot of the floor.
3. Place a string along the wall where lower Traxx is being placed. Make sure the string is level. (Figure A). Check along string to ensure 28 1/2" or greater dimension is maintained. This ensures proper clearance for the undersurface storage and support. Vertical adjustment of the fastener positions may be required if 28 1/2"H dimension is not maintained. Mark location of string at each end. Snap chalk line using the two points defined above. Center line of lower Traxx should be placed at the 28 1/2"H marked. (Figure B).
4. Determine position of upper Traxx based on the type of tiles specified; Cetra, Xsite, Interworks or conference room; using the center line of the lower Traxx as a reference point. (Figure C). Measure appropriate dimension from lower Traxx line and mark at each end. Snap chalk line using the two points defined above.

Figure A

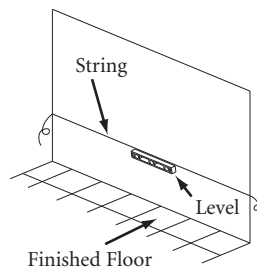

Figure B

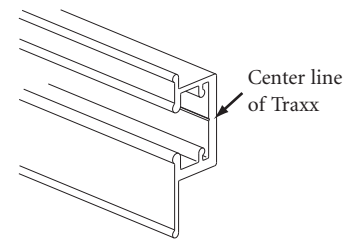
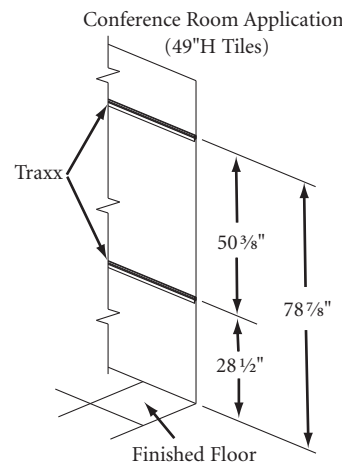
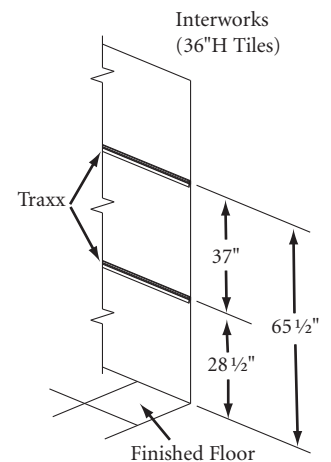
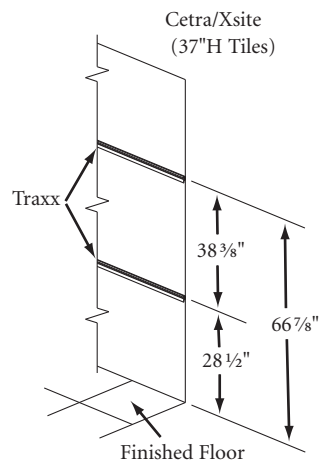

Figure C



Proper product installation, in accordance with these instructions, is the responsibility of the installing agent. If you have any questions concerning these instructions, please call Kimball Office Customer Service.

Kimball[®]Office

Traxx and Tiles

Installation (continued)

- Locate the wall substructure along the fastener location chalk lines. For proper attachment of Traxx to the wall, fasteners must tie directly into the substructure of the wall (studs, blocks, solid masonry). (Figure D). Select the appropriate fasteners for type of structural wall.

Note: Kimball International defines a structural wall as a load-bearing wall constructed of materials such as: poured concrete, concrete block, or studs. Wood studs must be a nominal 2" x 4" size minimum. Metal studs must be "C" channel, 20-gauge thick minimum. Metal or wood studs must be on centers no greater than 24" and have maximum height of 14' restrained at floor and ceiling. Interior walls shall be designed to resist not less than a force of 5 lbs. per square foot applied perpendicular to wall. The deflection of such walls under a load of 5 lbs. per square foot shall not exceed $\frac{1}{240}$ of the span for walls with brittle finishes, and $\frac{1}{120}$ of the span for walls with flexible finishes (per Uniform Building Code Section 2309b). If you have any questions concerning your load-bearing structures, please consult your architect or structural engineer.

- Prepare wall for Traxx attachment by pre-drilling for and/or installing fasteners along chalk lines per the fastener manufacturer's guidelines. Recommended spacing of fasteners is 16", but should not exceed 24" on center. When ending a run, **DO NOT** extend the Traxx more than 6" beyond the last anchor attachment. (Figure D).

Note: It is the responsibility of the installer and/or the contractor to select and install the proper fasteners in the structural wall. Kimball International does not furnish fasteners or assume liability for their use.

- Measure wall length at the upper and lower marked fastener positions. Cut the Traxx, when necessary, to the proper lengths.

Note: A single section of Traxx must attach to the wall with a minimum of two solid anchor attachment points.

Note: If the Traxx are installed at intersecting walls, an allowance is required for the installation of the Splice Plate. Install Splice Plate prior to attaching Traxx to the wall. The first length of Traxx installed will be reduced by $\frac{1}{4}$ " at each intersection. (Figure E).

Figure D

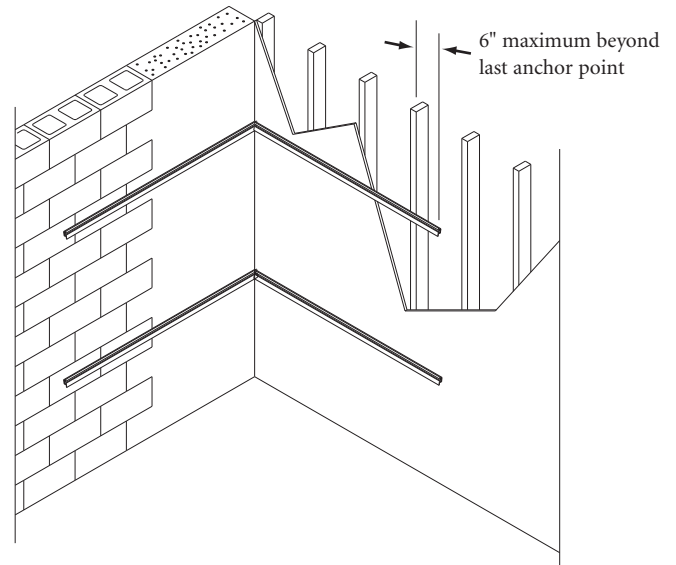
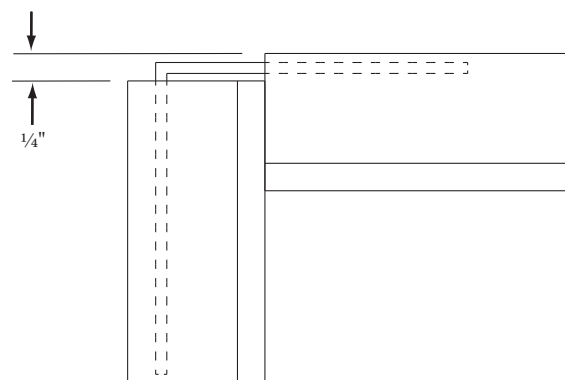

Figure E



Traxx and Tiles

Installation (continued)

8. Position the Traxx against the wall just below the chalk line. (Figure F). Transfer the fastener locations from the wall to the center line in the Traxx.
9. Drill the appropriate diameter hole in the Traxx per the fastener manufacturer's guidelines.
10. Before installing the Traxx, touch-up any exposed cut ends.
11. To align two adjacent pieces of Traxx, slide a Splice Plate into the channel at the back of the Traxx. Offset the "V" in the splice plate with the seam between Traxx and attach using provided #6 x 3/8" panhead screws. (Figure G). To align two adjacent pieces of Traxx at a corner intersection, bend the Splice Plate to the required angle at the notch provided and attach using provided #6 x 3/8" panhead screws. (Figure H).
12. With the Splice Plate installed, attach the Traxx to the wall. **Note:** Do not tighten the fasteners fully until the wall tiles have been installed. Do not install Splice Plate screws until after the Traxx fasteners have been tightened.

<u>Recommended Traxx Fasteners</u>	<u>Size</u>	<u>Model #</u>
Steel Stud		
(for 1/2" to 3/4" drywall):		
Hilti® Toggler® anchor toggle bolt	1/4"-20 x 2" grade 5 bolt	374494
Wood Stud (for 1/4" to 1/2" drywall; meets or exceeds ANSI/ASME B18.6.4 and SAE J933):		
Panhead sheet metal screw		10-2 PHPMS
Solid Masonry:		
Crown Bolt lag shields	1/4" x 1 1/2"	
Buildex Tapcon concrete anchor screw	1/4" x 2 3/4"	24385
Masonry Block:		
Hilti Toggler anchor toggle bolt	1/4"-20 x 2" grade 5 bolt	374494
Crown Bolt lag shields	1/4" x 1 1/2"	
Buildex Tapcon concrete anchor screw	1/4" x 2 3/4"	24385

Figure F

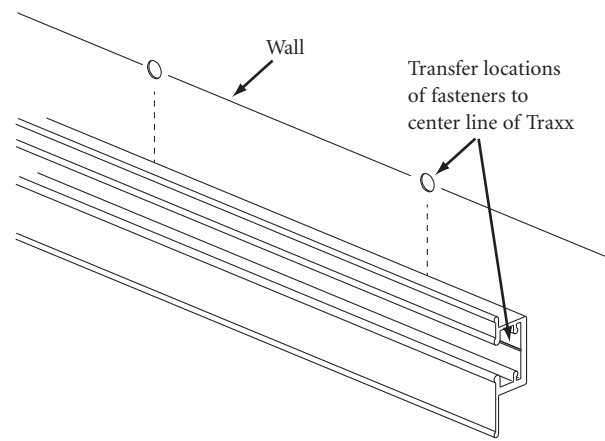

Figure G

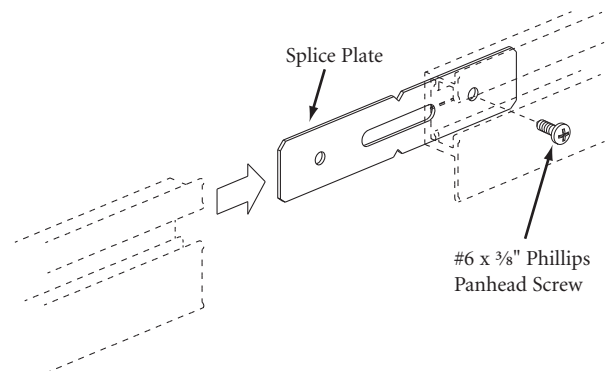
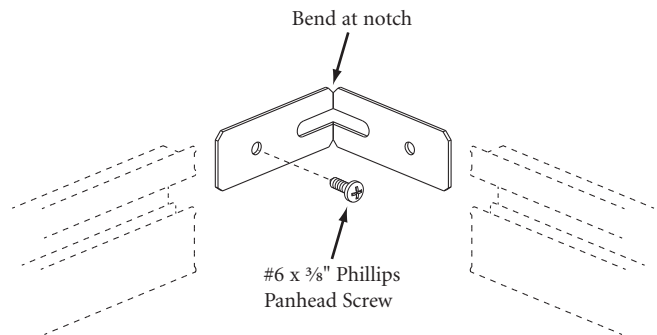

Figure H



Printed in U.S.A. © 2010 Kimball International, Inc. T 800.482.1818 F 812.482.8300

Proper product installation, in accordance with these instructions, is the responsibility of the installing agent. If you have any questions concerning these instructions, please call Kimball Office Customer Service.

Kimball Office

Traxx® and Tiles

End Trim Installation

Tools Required

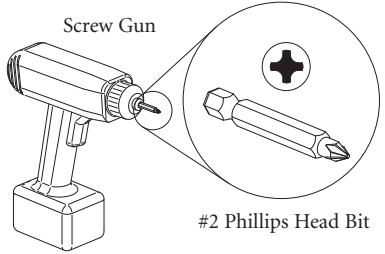

Package Contents



Installation

1. Slide the end trim behind the installed Traxx. (Figures A and B). Align top of end trim with top of Traxx.
2. Attach end trim to the Traxx using the screws provided. (Figure C).

Figure A

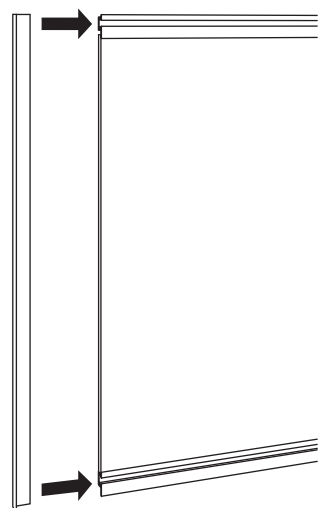

Figure B

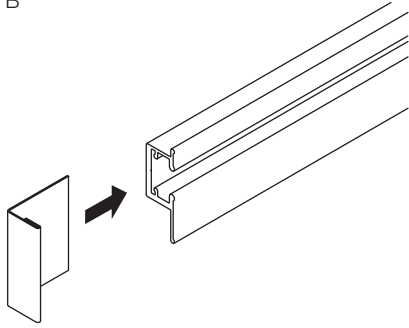
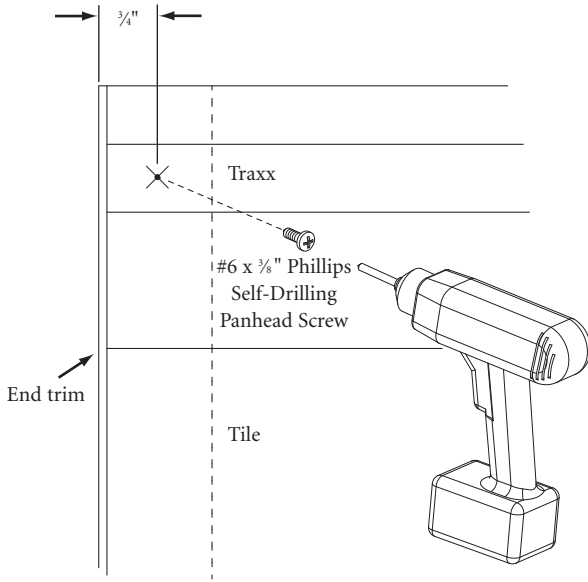

Figure C



Proper product installation, in accordance with these instructions, is the responsibility of the installing agent. If you have any questions concerning these instructions, please call Kimball Office Customer Service.

Kimball®Office

Traxx® and Tiles

Tile Installation (Fabric, Slat or Marker Board)

Tools Required

- Putty Knife
- Tape Measure
- Level
- Utility Knife

Installation

1. For fabric tiles only, determine top side of the tile by locating the “Traxx” sticker on the backside of the tile, and orientating the label right side up. (Figure A).
2. Tilt top of tile forward and insert top of tile behind lower lip of upper Traxx. (Figures B and C).
3. Push the bottom of the tile towards the wall until clear of the upper lip of the lower Traxx, and downward until tile is seated. (Figures D and E).
4. Insert all tiles and tighten Traxx fasteners.
5. Using a putty knife and level, adjust the trim channels to fill any gaps between tiles and to ensure channels are plumb. (Figure F). Dependent on layout of worksurface and storage components, the width of tiles may need to be adjusted to ensure proper alignment.

Figure A

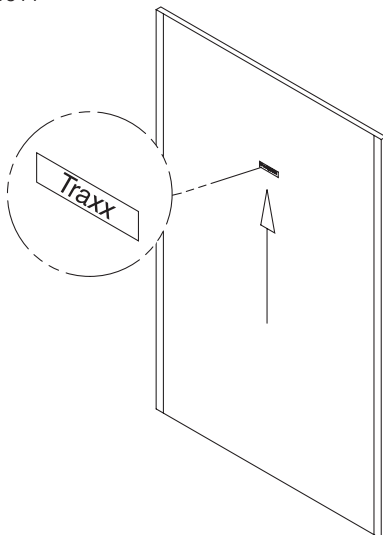
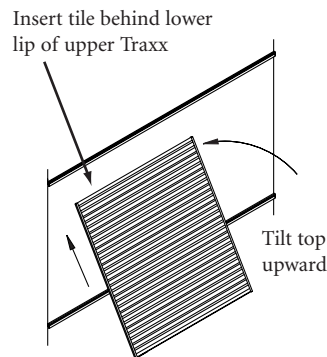

Figure B



Note: Aluminum Slat Tile shown.

Figure C

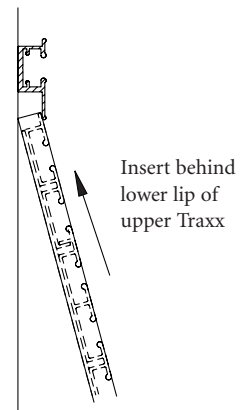

Figure D

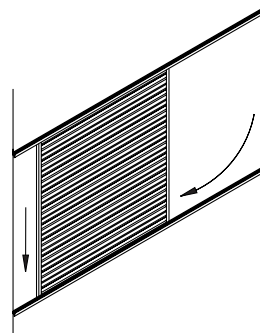

Figure E

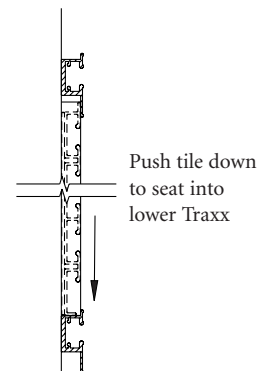
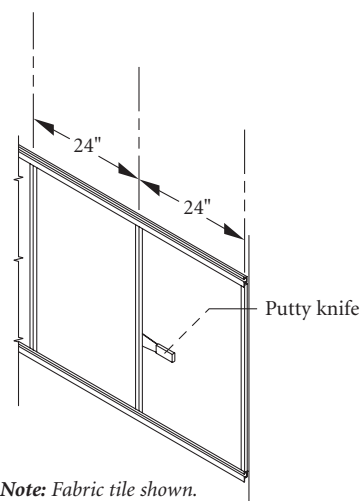

Figure F



Note: Fabric tile shown.

Proper product installation, in accordance with these instructions, is the responsibility of the installing agent. If you have any questions concerning these instructions, please call Kimball Office Customer Service.

Kimball®Office

Traxx and Tiles

Installation (continued)

Cutting Acoustic Tile

Tools Required

- Putty Knife
- Straight Edge
- Tape Measure
- Utility Knife

1. Take measurement of space where the tile will be placed to determine the appropriate width. (Figure A). Tiles should be cut $\frac{1}{4}$ " less than measurement.
2. Remove trim channel from end being cut.
3. Place tile on clean, solid surface, backside facing up.
4. Mark measurement near top and bottom of tile. (Figure B). Using a straight edge and utility knife cut the tile to desired width. (Figure C).
5. Replace trim channel and tile is ready to be installed.
6. Follow Steps 1-5 on page 1.

Figure A

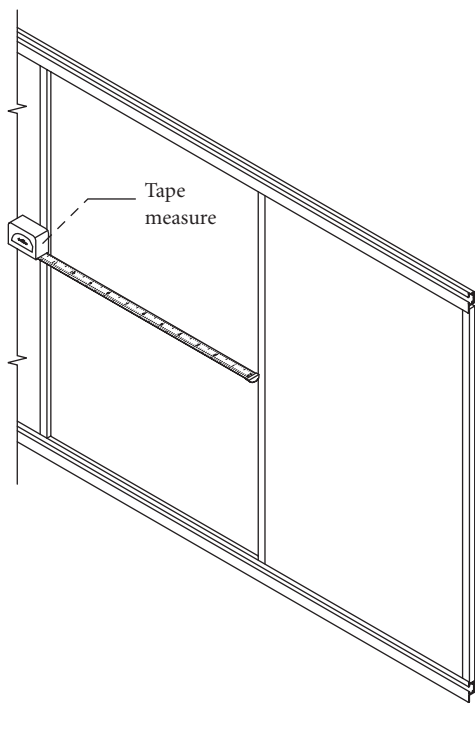

Figure B

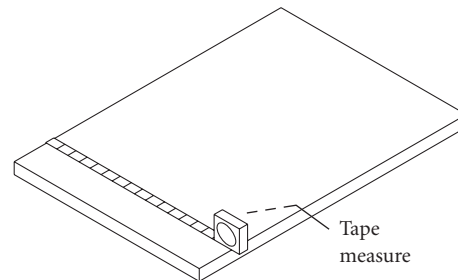
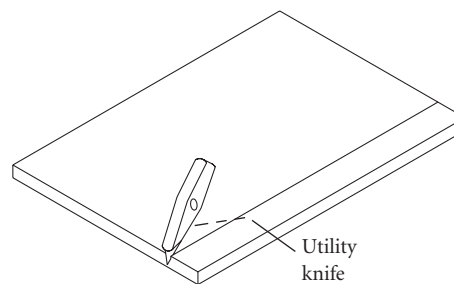

Figure C



Fastener Concealment

Tools Required

- Screwdriver or other blunt, thin object
- Scissors

Package Contents

- 1 Fastener Concealment (60' Roll)

Installation

1. Begin installation of fastener concealment by squeezing end into a "V" shape and place into the center reveal lower groove of Traxx. Press upper portion of concealment into groove. Continue installation ensuring the vinyl concealment stays in lower groove. Felt concealment is mounted into the center reveal, but does not need to be placed in the lower groove. (Figure A).
2. Use your finger or any blunt, thin object to push the fastener concealment securely into the center reveal. Be careful not to scratch the Traxx. Continue to insert the fastener concealment the length of the Traxx channel. (Figure B).
3. At the end of the Traxx run, use scissors to cut fastener concealment to required length. Cut vinyl fastener concealment 3" longer than Traxx to compensate for any stretch and recoil.

Figure A

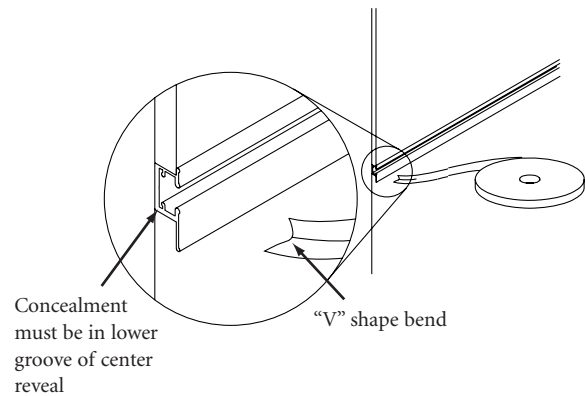
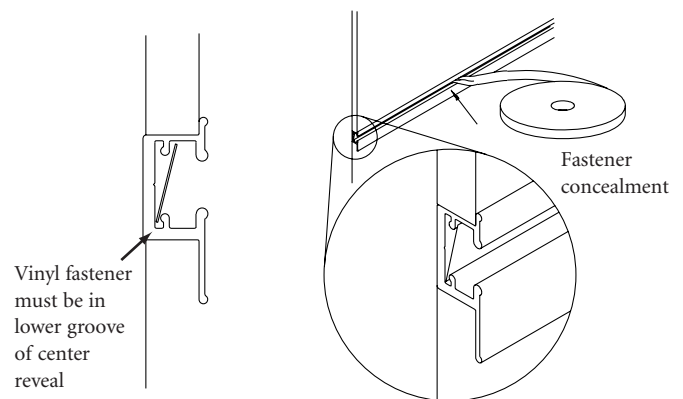

Figure B



General Information

- These instructions are to assist in the installation of an Interworks® panel perpendicular to installed Traxx. Acoustical panels are illustrated.
- One person is required to perform all operations.

Traxx Panel Starter Kit includes the following:

- Weld nut and screw for attaching Wall Mount to Traxx: two each for 66"H and 80"H Kits; one each for 34"H to 62"H Kits.
- One 60" strip of flexible, visual privacy tape
- Two washer nuts, which serve as spacers.

Tools Required

- Tape measure
- Level
- Slot head screwdriver
- Tools to install fasteners as listed in price list and Traxx Assembly Instruction AISYFP001C.

Interworks Products Required:

- (2) Panel Hinges, same height as Kit.
- In-Line Fill Cap or Side Rail End Cap is recommended to fill gap between panel top cap and Traxx. Contact your Customer Care Team to order.

Cautions

- Traxx must be previously installed using recommended fasteners and within specifications listed in price list and Traxx Assembly Instruction AISYFP001C.
- Kit must be attached to Traxx and or wall at a minimum of two points.

Installation

- 1a. Position Wall Mount perpendicular to Traxx where starter panel is required. Level for vertical plumb and mark Traxx (Figure A).

Figure A

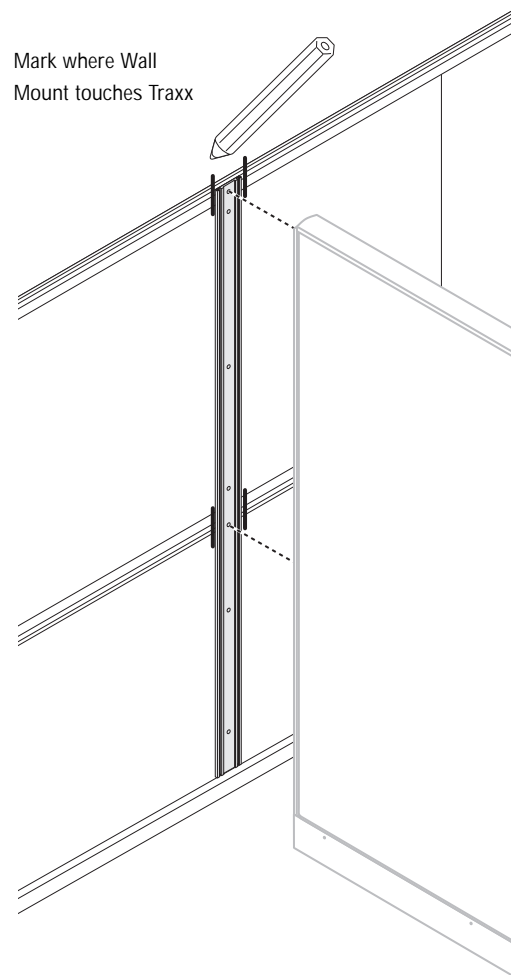

Proper product installation, in accordance with these instructions, is the responsibility of the installing agent. If you have any questions concerning these instructions, please call your Customer Care Team.

Installation

1b.

NOTE: If Traxx is only used in lower position OR if Kit/panel is less than 66"H, locate bottom of Wall Mount about $3\frac{7}{16}$ " from finished floor. Mark where lowermost hole in Wall Mount would meet wall, approximately $9\frac{7}{16}$ " from finished floor (Figure B). This mark will be used to install spacers.

2. With Wall Mount pressed against Traxx, measure where lowermost Traxx meets underside of Wall Mount. This mark determines how much privacy tape you'll need.
3. Lay Wall Mount aside. Measure distance from mark on underside of Wall Mount to bottom edge of Wall Mount. Transfer this measurement to privacy tape and cut two equal lengths, approximately $28\frac{1}{2}$ ". Remove backing and apply to underside of Wall Mount.

4. Insert screws through appropriate hole in Wall Mount and start weld nut onto screws. Slip weld nut(s) into recess of installed Traxx using locator marks from Step 1a as a guide. Realign Wall Mount to Traxx, using level to ensure vertical plumb, and secure Wall Mount to Traxx using screws(s) provided (Figure C). As screw is tightened, weld nut pulls Wall Mount flush and secure to Traxx. Do not overtighten screw.

NOTE: If Traxx is only used in lower position OR if Kit/panel is less than 66"H, secure Wall Mount to wall at location determined in Step 1a, making sure the two spacers provided are installed behind the Wall Mount.

5. With Wall Mount secured to Traxx, secure panel to Wall Mount with Panel Hinges (Figure D).
6. If needed, insert In-Line Fill Cap into panel top cap to enclose gap between Wall Mount and panel top cap. Replace panel top cap (Figure E).
7. Adjust panel glides as necessary.

Figure B

66"H Kit Illustrated

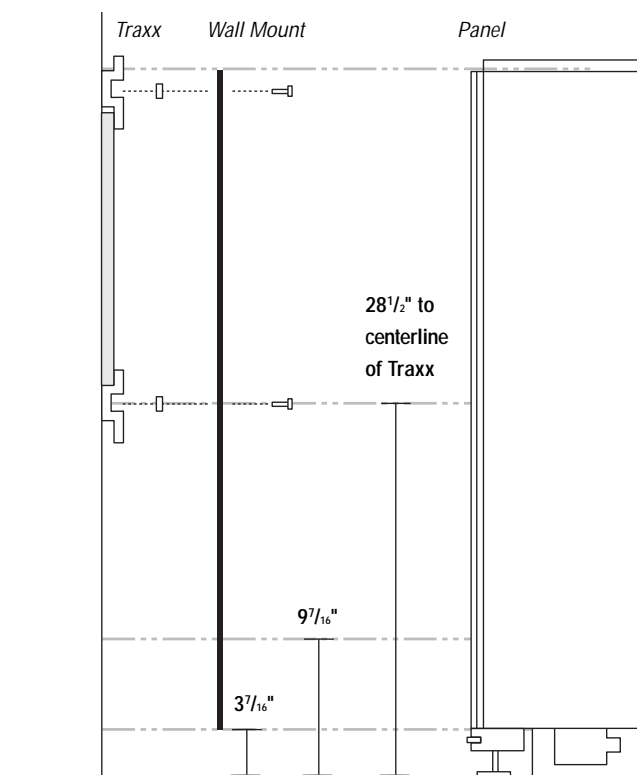

Figure C

Weld nut and screw secures Wall Mount to Traxx

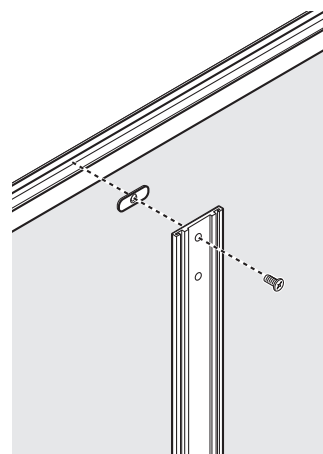

Figure D

Panel Hinges

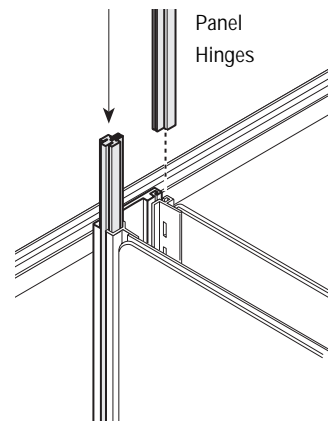
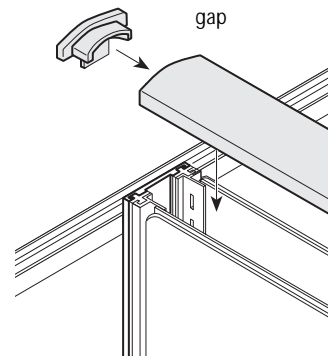

Figure E

In-Line Fill Cap or Side Rail End Cap encloses gap



Footprint®

Traxx®-Mounted Square, Radius, or Curved Profile Overheads

Tools Required

- Variable-speed drill with torque option
- 3/8" drill bit
- Tape measure
- Level
- #2 Phillips bit
- Two "C" clamps
- Phillips screwdriver
- 5mm Allen wrench

Description

Square, radius, or curved overheads may be hung from Traxx using a Traxx overhead attachment bracket, model FBOTS. If installing overheads side by side, a ganging kit, model FSTG, is also required. (Figure A).

Installation

1. Insert hook on the top of the bracket into the Traxx at a 15° angle (Figure B).
2. Pull downward on the bracket allowing bracket to hang off of the Traxx (Figure C).
3. Install the remaining brackets required to hang the overhead:
 - 24"W–48"W cabinets require two brackets
 - 60"W–72"W cabinets require four brackets
4. Install the overhead by tilting the bottom of the cabinet approximately 15° away from the wall, and engaging the bracket on the inside of the cabinet onto the overhead bracket on the Traxx (Figure D).

Figure B

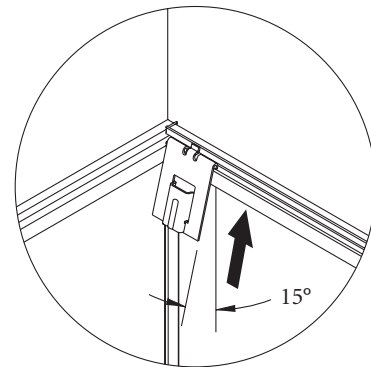

Figure C

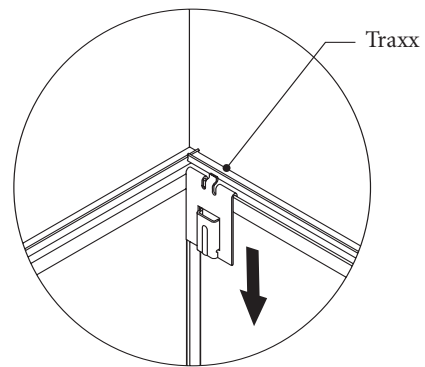

Figure D

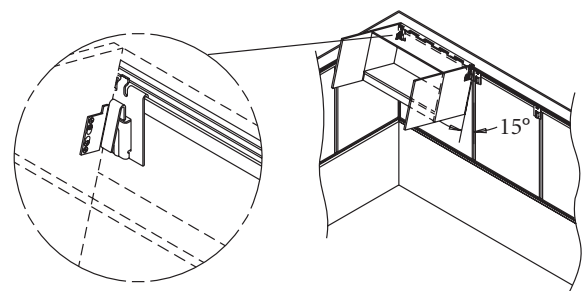
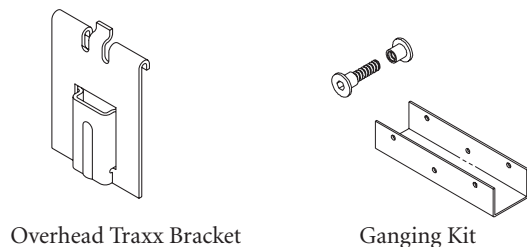

Figure A



Footprint®

Traxx®-Mounted Square, Radius, or Curved Profile Overheads, continued

5. Let cabinet rest against the tile(s).
6. Hang any additional overheads.
7. Level the overheads, if necessary, by loosening screws on the bracket inside the overhead and adjust accordingly. Tighten all screws after leveling (Figure E).
8. If overheads are installed side by side, a ganging kit is required (Figure A). To install ganging bracket, begin by removing the doors on hinged-door cabinets and open the door on receding and flipper-door cabinets.
9. Using "C" clamps, clamp the top and bottom of the end panels on the overheads. Make sure the top, bottom, and front edge on the end panels are aligned. (Figure F).
Tip: When clamping the end panels, use a spacer between the clamps and the end panels to prevent damage.
10. Attach the "U" alignment bracket to the end panels on the underside of the adjacent overheads using the four Phillips head #8 x 5/8" screws provided (Figure F).
11. Measure inward approximately 4 3/4" from the front end of the end panels and down approximately 3 1/2" from the bottom of the top panel. Drill a 3/8"-diameter hole through both end panels. Insert alignment screw provided into the hole and tighten with an Allen wrench until gap between overheads is even. (Figure G).

Figure E

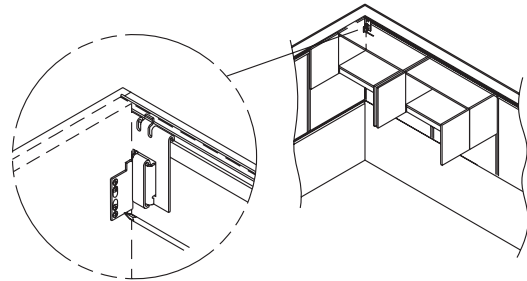

Figure F

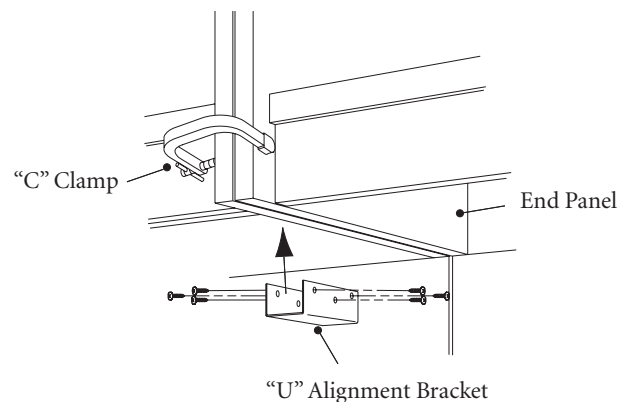
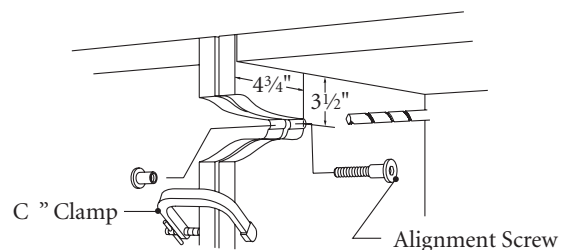

Figure G



Traxx®-Mounted Square, Radius, or Curved Profile Overheads, continued

12. For hinged-door models, adjust door alignment as necessary. There should be a slight gap between the doors and doors should be level with each other when they are properly aligned.

Doors out of horizontal alignment (Figure I): Turn screw labeled “A” (Figure H) clockwise to decrease margin or counterclockwise to increase margin.

Doors out of vertical alignment (Figure J): Loosen screws labeled “B” (Figure H). Reposition door up or down for proper alignment. Retighten screws.

Note: Vertical misalignment can also occur if unit is not level.

Doors out of alignment with the side of the overhead (Figure K): Slightly loosen screw labeled “C” (Figure H). Reposition door. Retighten screw.

Figure H

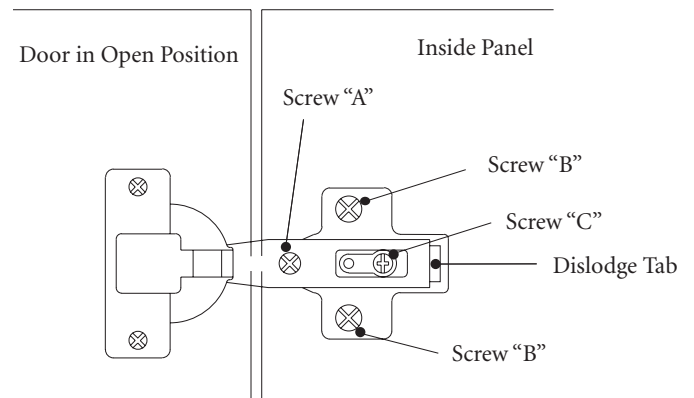

Figure I

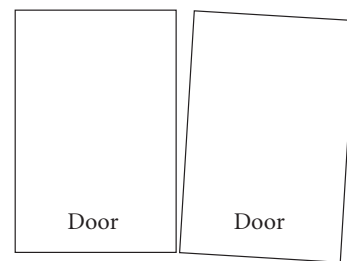

Figure J

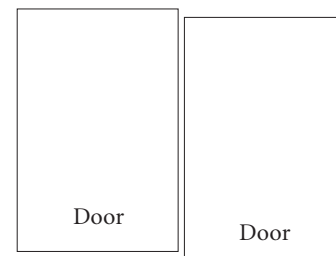
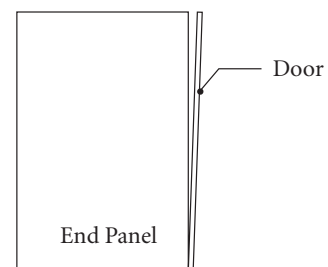

Figure K



Printed in U.S.A. © 2008 Kimball International, Inc. T 800.482.1818 F 812.482.8300

Footprint®

Lunar Overhead Storage Cabinet Ganging Bracket for Xsite®/Traxx®

Tools Required

- Electric Drill/Driver
- Rubber (non-marring) Mallet
- #3 Phillips Head Bits

Package Contents

- 1 Ganging Bracket
- 2 #10 x 1/2" Self-drilling Phillips Panhead Screws

Installation

Note: This instruction covers installation of ganging brackets for all Lunar cabinetry assembled and installed on Xsite and Traxx only. All operations to assemble the cabinet and doors can be done by one person, but it is recommended that two people install the units to the panel system/Traxx.

Important: This instruction explains basic Lunar ganging bracket assembly techniques. Please see assembly instruction "Lunar Overhead Storage, Flipper Door Cabinet" for basic cabinetry assembly and installation to panel systems as needed.

Purposes of the ganging bracket:

- To align the front lower edge of the adjacent cabinet.
- To add rigidity to the installed cabinets.

Pre-installation action: As mentioned above, reference assembly instruction "Lunar Overhead Storage, Flipper Door Cabinet" to assemble all cabinetry and install it to Xsite panels and/or Traxx. Take care to not damage the unit(s) or the panel. Inventory the package contents before proceeding with assembly/installation. Stop if there are insufficient items to complete the assembly.

1. Figure A shows a single door Lunar overhead cabinet for reference.
2. Figure B shows a typical side-by-side application for ganging on an Xsite panel run.

Figure A

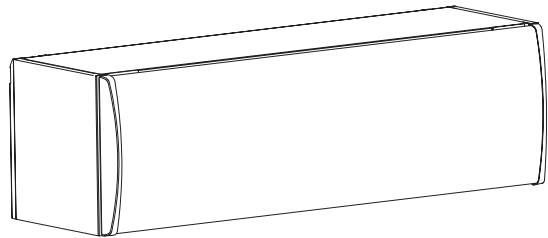
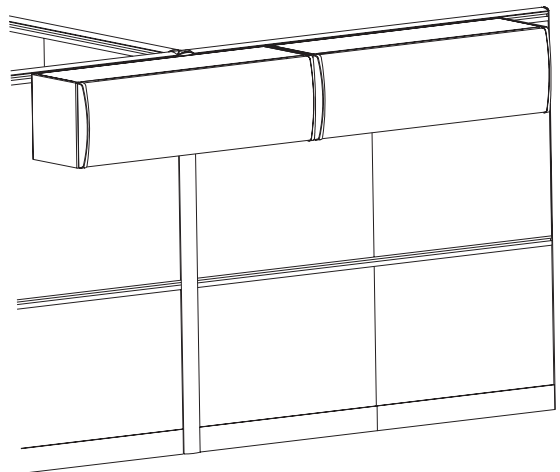

Figure B



Footprint

Installation (continued)

3. Position the cabinets in their leveled and desired location.
To slide cabinets right or left, lift the lower front edge of each cabinet, thus lifting the cabinet away from the panel face(s). Open the cabinet doors and fully slide them back. Press the adjacent cabinets together by pushing horizontally and slightly lifting the front edge of each cabinet. The cabinet ends must be in direct contact with no gaps. (Figure C).
4. Continue pushing and slightly lifting the cabinets. Loosely position the ganging bracket under the lower front flanges of the cabinet so that the vertical “ears” of the ganging bracket are directly behind the edge of the lower front shelf flange. (Figure D).
5. With the ganging bracket in position, press the bracket upward to its final fully-seated position. Significant pressure will be required as the bracket “ears” are intended to grip the interior end panels of the cabinet, aiding in positioning/holding power of the assembly. A rubber non-marring mallet may be needed to fully seat the bracket. (Figure E).

Figure C

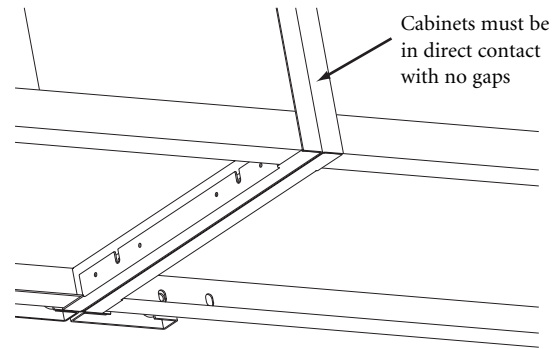

Figure D

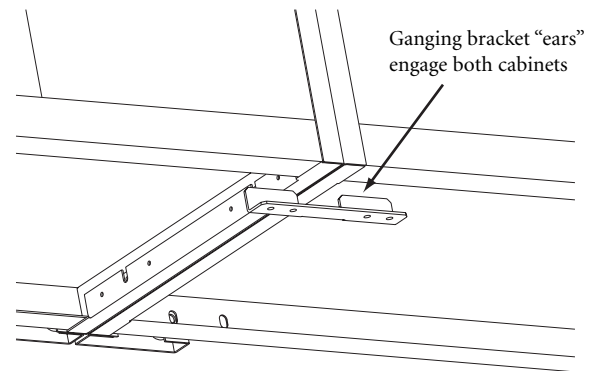
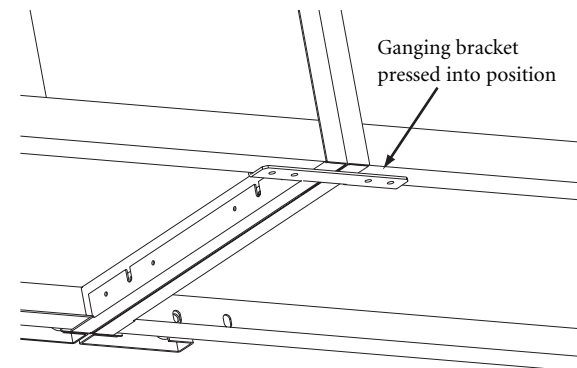

Figure E



Footprint

Installation (continued)

6. Continue pushing and slightly lifting the cabinets. Install the self-drilling screws into either of the holes, one per side, in the lower flange of the ganging bracket, drilling directly into the lower flange of the cabinet shelf. Two holes per side are provided in case the initial attempt at screw installation fails and will allow a second try without having to field drill the ganging bracket. To obtain the best grip, angle each screw outward from the center of the bracket, which positions each screw to the most outward edge of its hole in the bracket. This forces the edge of the bracket hole to be in direct contact with the screw thread as it is engaged, thus not allowing slippage. (Figure F).
7. After all screws are firmly installed, lower cabinets down to their normal position. Re-check that the front, lower edges of the cabinet end panels are in alignment and are in direct contact with no gaps. (Figure G).
8. Close cabinet doors. Per previous assembly/installation instructions, re-check all door and lock operation.

Figure F

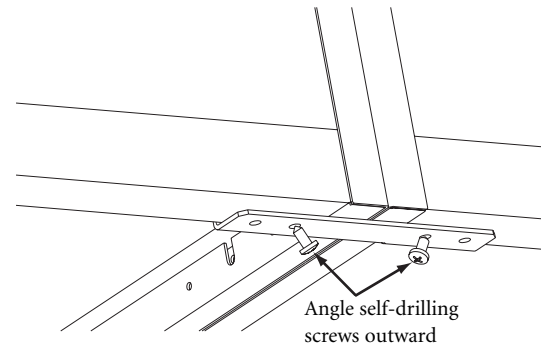
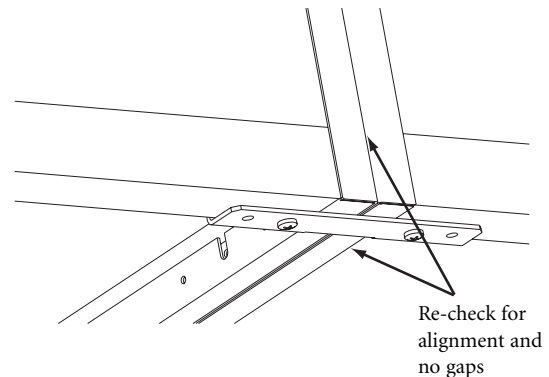

Figure G



Footprint®

Overhead Storage and Full Height Shelf To TRAXX®

Tools Required

- Tape Measure

Product Required

- Traxx Adapter Bracket Kit 1 set (required when hanging Overhead Storage and Full Height Shelf on Traxx **WITH** Tiles)
- Traxx Adapter Bracket Kit 1 set and Traxx Spacer Bracket, 1 set (required when hanging Overhead Storage and Full Height Shelf on Traxx **WITHOUT** Tiles)

General Information

- These instructions provide the basic information to install Interworks EQ® full height shelf and overhead storage receding door units onto Traxx.
- The installation process is the same for overhead storage and shelf. Overhead storage is illustrated.
- Half height shelf is not designed for use with Traxx.
- Units hang onto Traxx via vertical hooks in overhead unit. These hooks slip into slots in the Traxx adapter bracket kit.
- Use of the Traxx adapter bracket kit without tiles will cause the overhead unit to hang at a slight angle.
- The Traxx spacer bracket will “stand-off” the overhead unit from the wall, allowing the overhead to hang flush.
- For larger units, two persons are recommended to perform installation.

Installation

To Traxx—When Tiles ARE Used

1. Determine horizontal position at which unit will be located.
2. Install two Traxx adapter brackets into top track of Traxx. (Figure A).
3. Adjust location to correspond to width of overhead unit.
4. Lift unit into position and slide the hooks on the back of the unit into the corresponding opening of the installed brackets. (Figures A and B). Allow unit to rest in vertical position.

Figure A

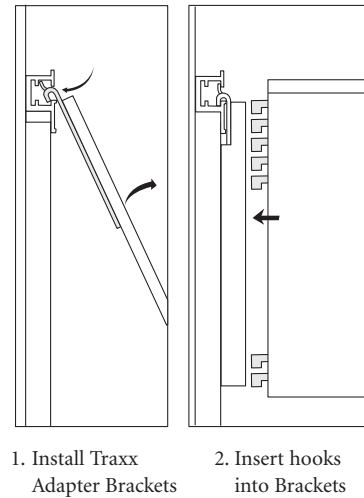
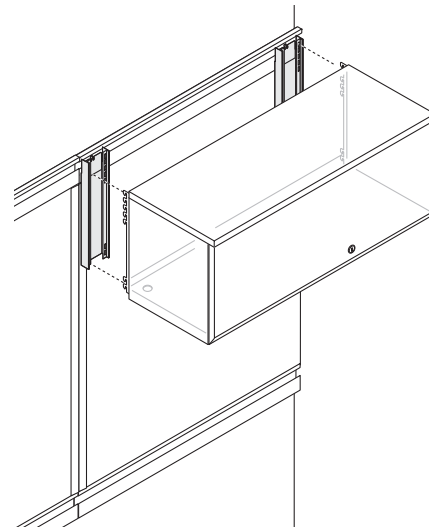

Figure B



Installation (continued)

To Traxx—When Tiles ARE NOT Used

1. Remove protective strip from one side of double-sided adhesive tape (provided) and adhere to the innermost edge of each Traxx spacer bracket flange, leaving approximately 1/8" uncovered from the outside flange edge. (Figure C). Discard remaining double-sided tape.
2. Remove the protective strip from the double-sided tape that is adhered to each Traxx spacer bracket.
3. Mount Traxx spacer bracket to Traxx adapter bracket, ensuring the brackets are flush at the lower end. (Figure D).
4. Follow Steps 1 through 4 “When Tiles Are Used.”

Figure C

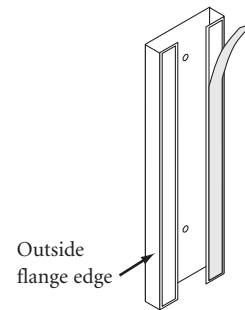
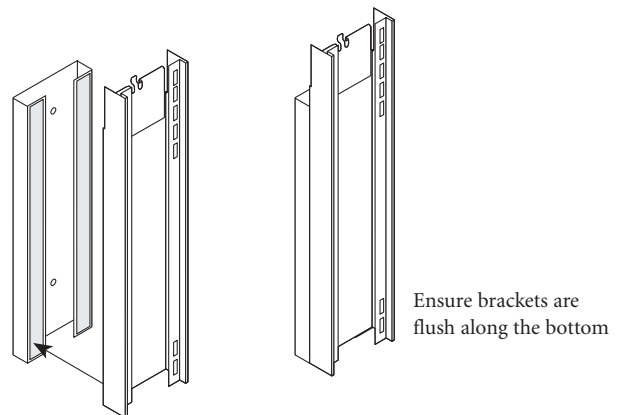

Figure D



Footprint®

Installing Xsite®/Traxx® Panel Attachment Brackets to Lunar Overheads

Tools Required

- #3 Phillips Screwdriver
- 7/16" Hex Socket
- 1/4" or 3/8" Socket Driver
- 7/16" Open End Wrench

Package Contents

- 2 Xsite/Traxx Panel Attachment Brackets for 24"W, 30"W, 36"W, 42"W and 48"W Units. (Single door units).
- 3 Xsite/Traxx Panel Attachment Brackets for 60"W and 72"W units. (Double door units).
- 1/4" Bolt and Flanged Nut

Note: This instruction covers installation of panel attachment brackets to Lunar overheads that will be mounted on Xsite or Traxx. All operations to assemble the bracketry can be done by one person, but it is recommended that a two person team assemble and install the units to the panel system or Traxx.

Important: Reference the assembly instruction "Lunar Overhead Storage, Flipper Door Cabinet" for assembly of the Lunar Overhead. The units are assembled in the inverted position. Moving the units without the bracketry attached can cause damage, therefore all bracketry in this instruction is installed with the overhead unit in the inverted position.

1. The assembled overhead unit is in the inverted position. (Figure A).
2. All brackets are attached using 1/4" bolts and flanged nuts. Turn bracket so that the heavy steel hooks are towards the top of the unit. Take note of location of mounting holes and attach bracket to unit using four (4) bolts and four (4) flanged nuts per bracket. There are two weld nuts attached to the inside of each bracket. Insert a bolt into the outermost weld nut from **INSIDE** the overhead unit. All other bolts insert from inside the overhead unit. (Figure B).

Figure A

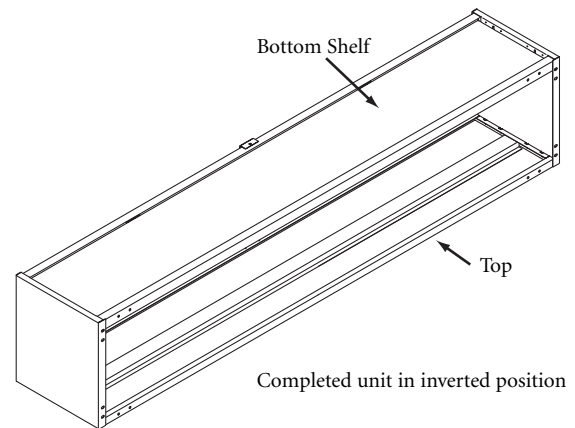
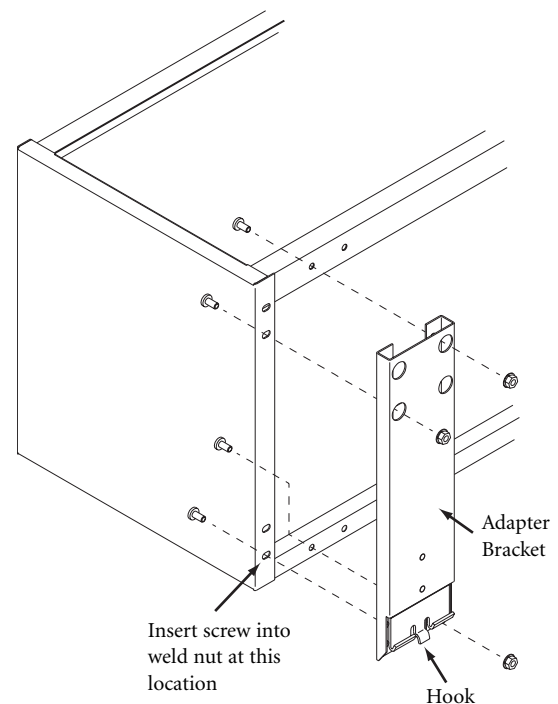

Figure B



Footprint

Installation (continued)

3. Take note of location of mounting holes and attach second bracket to opposite end of unit. (Figure C). Similarly for double door units (60"W and 72"W), attach the third (supplied) bracket to the mounting holes in the shelf at the center of the unit using four (4) bolts and four (4) flanged nuts. (Figure D).
4. In instances where the Lunar overhead will be mounted to Traxx when tiles are not used, a Traxx spacer bracket must be attached to each adapter bracket. The spacer brackets are ordered separately. Reference assembly instruction Traxx Spacer Bracket for proper installation.
5. Carefully turn assembled unit to its upright position. It is recommended that two persons be used to lift the unit to its final position. Lift unit and tilt backwards approximately 30°- 45°. Engage the steel hooks on the mounting brackets into the center channel of the Traxx rail, then allow the bottom of the unit to rotate downward into its final position. (Figure E).

Figure C

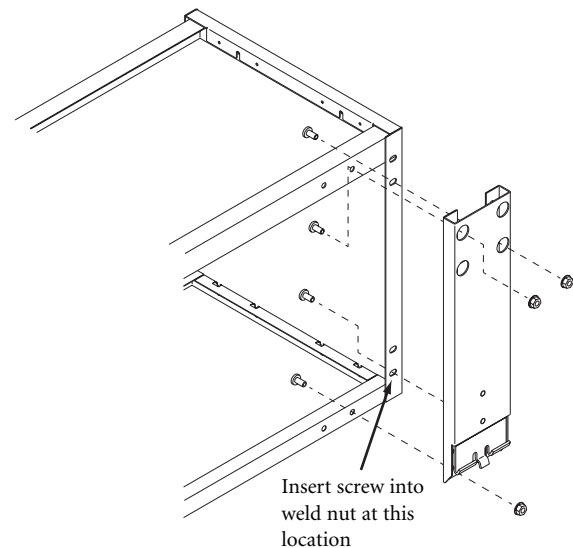

Figure D

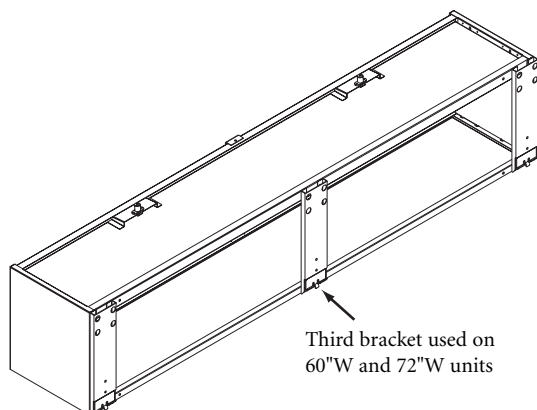
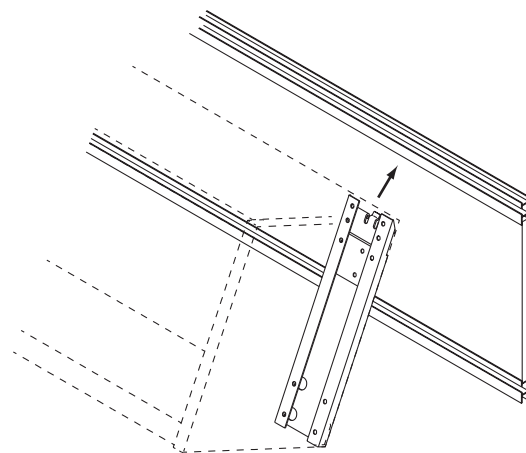

Figure E



Footprint®

Storage Cubby for Xsite and Wall Mounted Traxx

Tools Required

- Screwdriver
- Level

Installation

1. Storage cubbies are mounted using a series of upper tabs and integral flanges which are riveted to the back of cubby. (Figure A).
2. Tilt the cubby and slide the upper tabs into the extrusion slot and push cabinet up against the upper edge of the extrusion slot. While holding the cubby against the edge of the extrusion slot, rotate the cubby allowing the integral flanges to swing into the same extrusion slot. Allow the cubby to lower until the integral flanges rest against the lower extrusion slot edge. Ensure that all tabs and integral flanges are inside the extrusion slot. (Figure B).
3. To raise the front of cubby for leveling, loosen screws and slide bracket towards the back. To lower front of cubby, slide bracket towards the front. Tighten screws when cubby is level. (Figure C).

Figure A

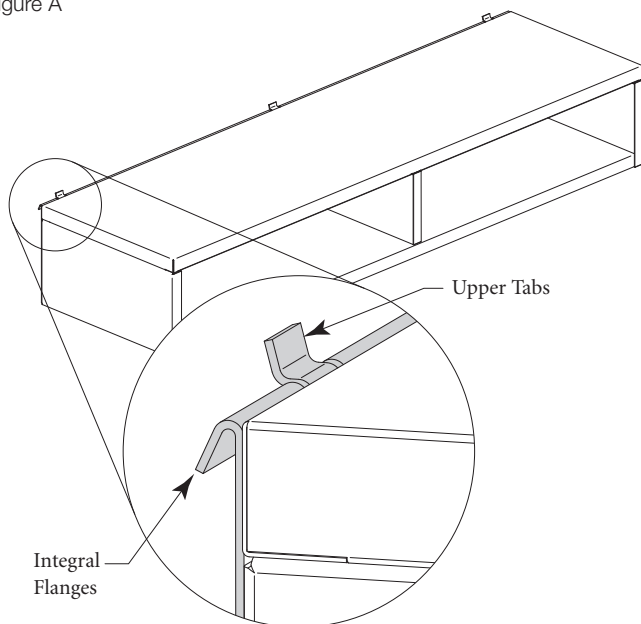

Figure B

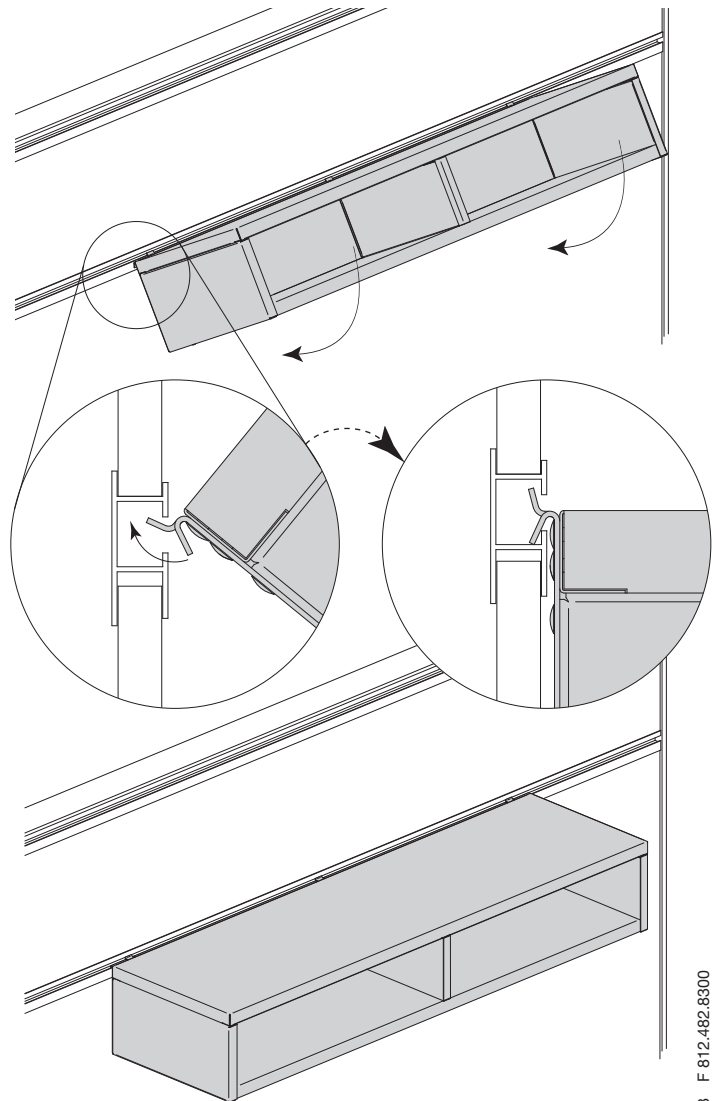
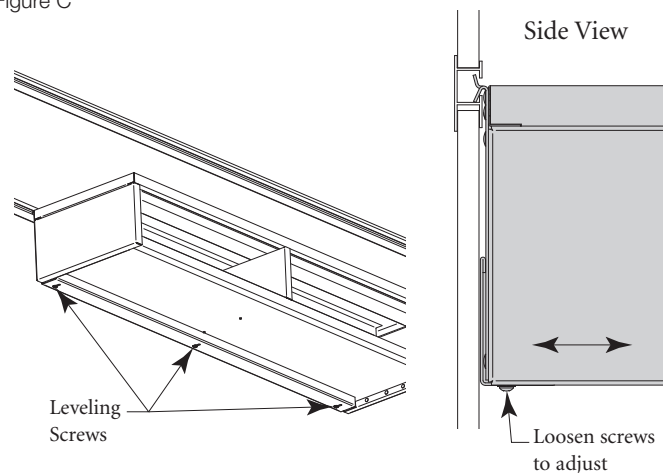

Figure C



Printed in U.S.A. © 2009 Kimball International, Inc. T 800.482.1818 F 812.482.8300

Proper product installation, in accordance with these instructions, is the responsibility of the installing agent. If you have any questions concerning these instructions, please call Kimball Office Customer Service.

Kimball®Office

Lunar

Lunar Overhead TRAXX® Spacer Bracket

Tools Required

- Utility Knife
- Tape Measure

Package Contents

- 2 Spacer Brackets
- Double-sided Adhesive Tape

Note: This instruction covers installation of spacer brackets onto Lunar cabinetry to be mounted on Traxx in instances where tiles are **NOT USED**. All operations to install the bracketry can be done by one person, but it is recommended that a two person team assemble and install the completed units to the panel system/Traxx.

Important: Reference the assembly instruction “Lunar Overhead Storage, Flipper Door Cabinet” for assembly of the Lunar Overhead, and reference the assembly instruction “Installing Xsite/Traxx Panel Attachment Brackets to Lunar Overheads” for installation of Panel Attachment Brackets. The units and attachment brackets are installed in the inverted position, therefore all bracketry in this instruction is installed with the overhead in the inverted position.

1. The completed unit must be in the inverted position.
2. The spacer bracket is supplied with double-sided adhesive tape. Cut two strips to length for each bracket. Remove protective strip from one side of double-sided adhesive tape and adhere to the innermost edge of each Traxx spacer bracket flange, leaving approximately 1/8" uncovered from the outside flange edge. Remove the protective strip from the double-sided tape that is adhered to each Traxx spacer bracket. Mount Traxx spacer bracket to Traxx adapter bracket making sure both brackets are flush on the lower end. Reference Interworks assembly instruction Overhead Storage and Full Height Shelf to Traxx. (Figure A).

Figure A

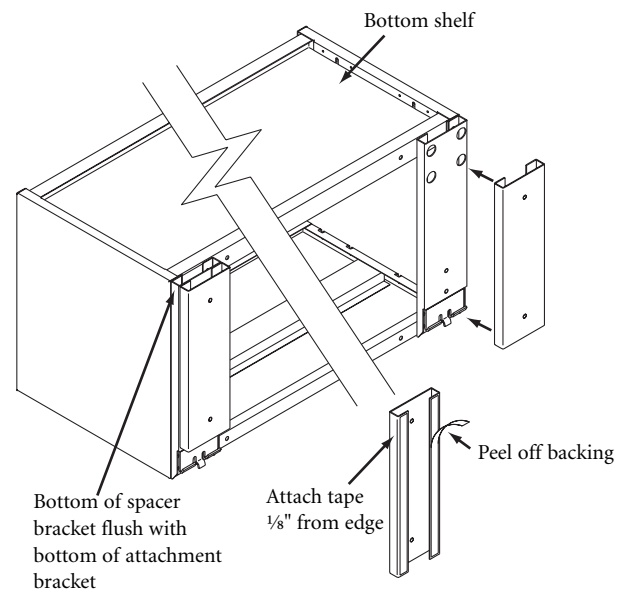

Footprint®

Wall Mount Spacer Strip

Tools Required

- Saw
- Black Marker

Package Contents

- Spacer Strip

Installation

1. Cut strip to cabinet width, if cabinet is less than 72" W.
2. If the strip has been cut, blacken the cut end using a black marker.
3. Remove peel strip from double stick tape. Apply strip to back of cabinet at location shown. (Figure A).

Figure A

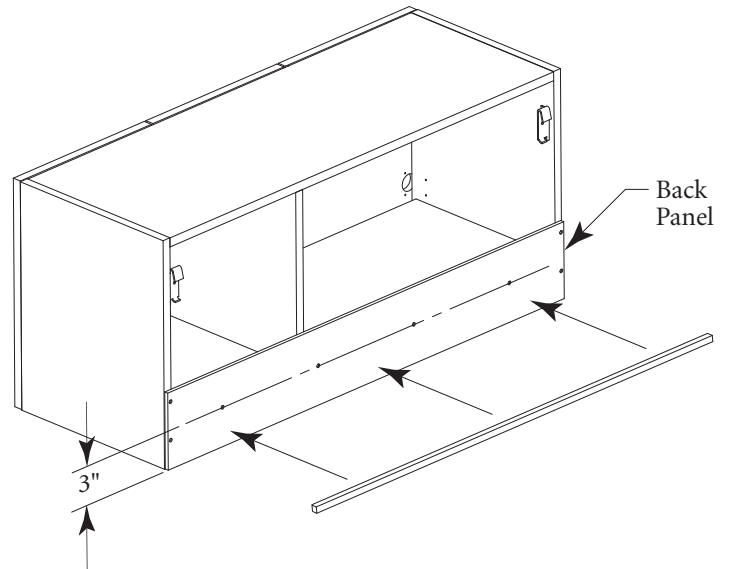

Footprint®

Wall Mounted Overhead (Traxx®)

Tools Required

- Tape Measure
- Level
(4 feet or greater)
- Metal Saw
- Variable Speed Drill
with Torque Option
- Drill Bits
- Screw Bits

Package Contents

- Traxx (72" section)

Installation

Note: Kimball International defines a structural wall as a load-bearing wall constructed of materials such as: poured concrete, concrete block, or studs. Wood studs must be a nominal 2" x 4" size minimum. Metal studs must be "C" channel, 20-gauge thick minimum. Metal or wood studs must be on centers no greater than 24" and have maximum height of 14' restrained at floor and ceiling. Interior walls shall be designed to resist not less than a force of 5 lbs. per square foot applied perpendicular to wall. The deflection of such wall under a load of 5 lbs. per square foot shall not exceed $\frac{1}{240}$ of the span for walls with brittle finishes, and $\frac{1}{120}$ of the span for walls with flexible finishes (per Uniform Building Code Section 2309b). If you have any questions concerning your load-bearing structures, please consult your architect or structural engineer.

1. Mark the Traxx center line position on the wall $66\frac{7}{8}$ " from the floor for the length where the overhead is to be located. (Figure A). Check several positions along the line to ensure that the dimension is not less than $66\frac{7}{8}$ ".
2. The 72" Traxx will have to be field-cut if a smaller single cabinet is to be used. The Traxx length should be equal to the width of the overhead cabinet(s).
3. Locate the wall substructure along the line drawn in Step 1. For proper attachment of Traxx to the wall, fasteners must tie directly into the substructure of the wall (studs, blocks, solid masonry).

4. Prepare wall for Traxx attachment by pre-drilling for and/or installing fasteners along the line drawn in Step 1 per the fastener manufacturer's guidelines. Recommended spacing of fasteners is 16", but should not exceed 24" on center. A single section of Traxx must attach to the wall with a minimum of two solid anchor attachment points. **DO NOT** extend the Traxx more than 6" beyond the last anchor attachment. (Figure B).

Note: It is the responsibility of the installer and/or the contractor to select and install the proper fasteners in the structural wall. Kimball International does not furnish fasteners or assume liability for their use.

Figure A

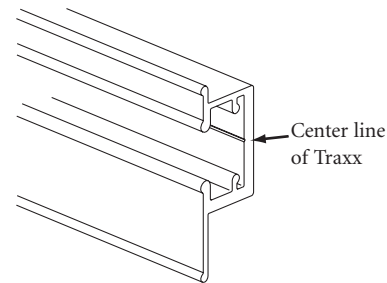
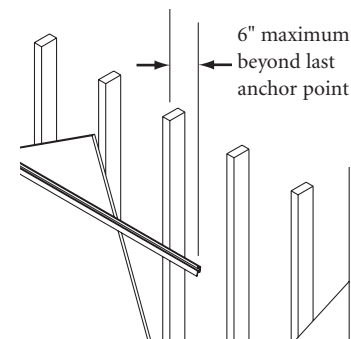

Figure B



Footprint

Installation

- Position the Traxx against the wall just below the line drawn in Step 1. (Figure C). Transfer the fastener locations from the wall to the center line in the Traxx.
- Drill the appropriate diameter hole in the Traxx per the fastener manufacturer's guidelines.

Note: Hole sizes are dependent on the size of the fastener selected.

Recommended Fastener	Size	Model No.
Steel Stud (for 1/2" to 3/4" drywall): Hilti Toggler anchor toggle bolt	1/4"-20 x 2" Grade 5 or equivalent	374494
Wood Stud (for 1/4" to 1/2" drywall; meets or exceeds ANSI/ASME B18.6.4 and SAE J933): Panhead sheet metal screw		10-2 PHPMS
Solid Masonry: Crown Bolt lag shields Buildex Tapcon concrete anchor screw	1/4" x 1 1/2" 1/4" x 2 3/4"	
Masonry Block: Hilti Toggler anchor toggle bolt Crown Bolt lag shields Buildex Tapcon concrete anchor screw	1/4"-20 x 2" Grade 5 or equivalent 1/4" x 1 1/2" 1/4" x 2 3/4"	374494

- Before installing the Traxx, touch-up any exposed cut ends.
- Attach Traxx to wall aligning the center line of Traxx to line drawn in Step 1. Ensure that each fastener is securely attached to wall substructure.

Figure C

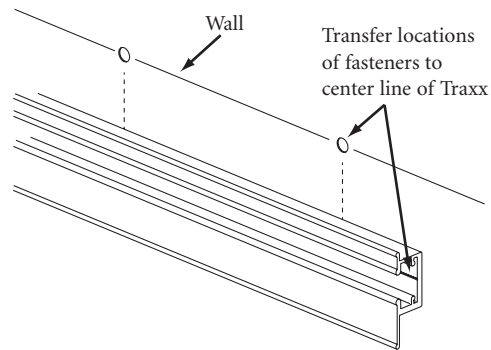

Footprint®

Traxx® Mounted Worksurface

Tools Required

- Screw Gun with Torque Option
- #2 Phillips Head Bit
- Tape Measure

Installation

Note: Worksurfaces can be Traxx mounted with worksurface brackets (Figure A) and supported with pedestals, end panels, and support bases. (Figure B).

1. Insert hook on the top of the bracket into the Traxx at a 45° angle. (Figure C).
2. Push the top of the bracket downward allowing bracket to hang off of the Traxx. (Figure D).

Note: The maximum distance between brackets should be no greater than 48". (Figure E). The maximum span of an unsupported worksurface should not exceed 48" for 1³/₁₆" worksurfaces and 60" for 1¹/₁₆" worksurfaces. Support is required within 6" of surfaces butted end-to-end. This may be a pedestal or 12" deep support panel.

3. Place worksurface on clean, solid surface, back side facing up. Install the flat brackets on the main worksurface, approximately 2" from front edge and approximately 6" from back edge of the adjoining worksurface using the screws provided. (Figure F). Ensure that the flat bracket attachment does not interfere with other brackets or components. Two flat brackets are required to join surfaces end-to-end or at a right angle.

Figure A

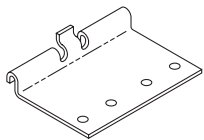

Figure B

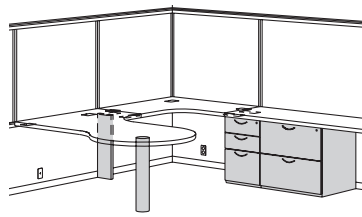

Figure C

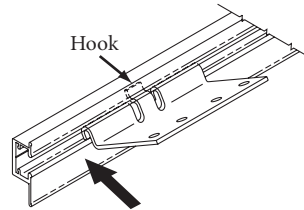

Figure D

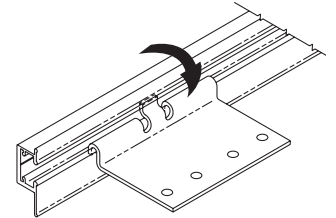

Figure E

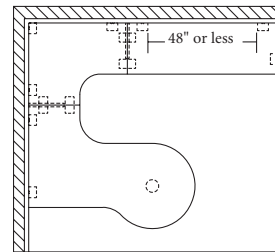
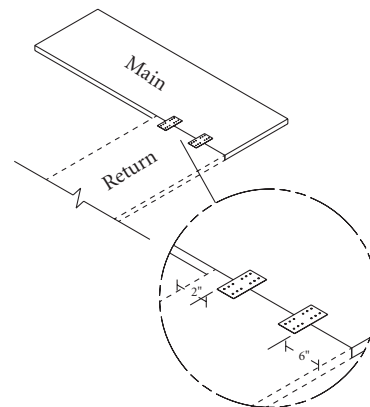

Figure F



Footprint

Installation (continued)

4. Lay the worksurface on the brackets. (Figure G).

Tip: Use an undersurface component as additional support until the worksurface bracket is secured to the surface.

5. Lay return worksurface onto brackets.

Note: When attaching two surfaces at a right angle, there will be a $\frac{1}{8}$ " gap between the wire manager and Traxx. (Figure H). If there is no wire manager, the surfaces should align. (Figure I).

6. Attach return worksurface to the flat brackets with screws provided. (Figure J). Eight screws are required per bracket.
7. Beginning at one end of the worksurface layout, apply pressure to the front of the ganged worksurfaces while controlling the gaps between the Traxx and back of worksurface.
8. Attach the worksurfaces to the worksurface brackets using the screws provided. (Figure K). A minimum of three screws are required per bracket.

Figure G

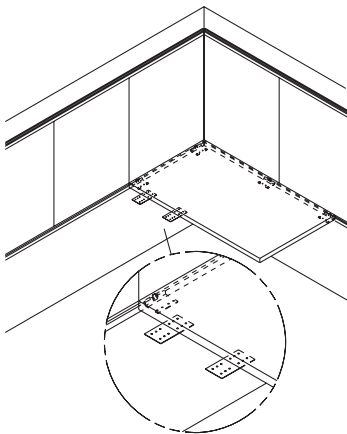

Figure H

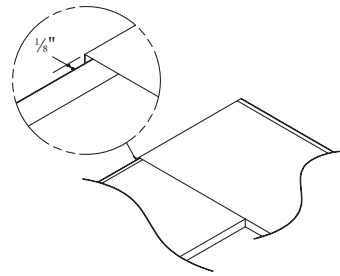

Figure I

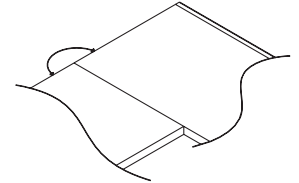

Figure J

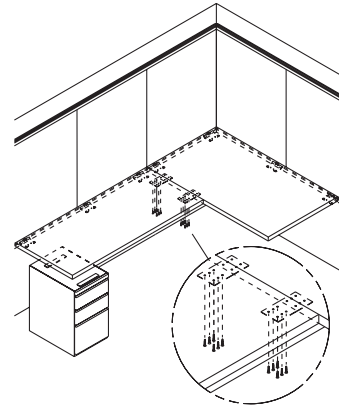
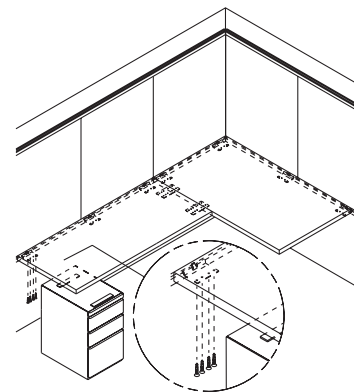

Figure K



Worksurface End Panel

Tools Required

- Drill with Torque Option
- #2 Phillips Head Bit
- 6" Magnetic Phillips Tip Bit or, Screwdriver
- Tape Measure
- Level

Package Contents

- #10 x 1" Phillips Panhead Particleboard Screws
- #10 x 1" Hex Washer Head Drill Tip Screws
- ¼-20 x ¾" Round Head Machine Screws

General Information

- These instructions provide the basic information needed to install any metal end panel into an Interworks® EQ panel.
- Corner worksurfaces are predrilled to accept End Panel for installation in standard flush left/right position.
- Installation process is similar for both half end panel (18"D) and full end panel (24", 30"D). Full end panel is illustrated.
- Unsupported worksurface span must not exceed 60". Kimball will not assume liability for any improperly or inadequately supported worksurface.
- Instructions are provided to install worksurface at standard desk height (28 ¾" actual height).
- End panel is designed to secure (Figure A):
 - a) Surface and panel at end of run when no wing panel is used or when undersurface is less than full depth/height.
 - b) Surface and panel when full height undersurface support is required, e.g. with some corner applications.
- End panel can be used to "share" load between two surfaces. (See Page 3).

Installation - End Panel/Worksurface Brackets

1. Smooth side should be facing away from the worksurface being supported by the end panel.
2. Two L-shaped end panel/surface brackets secure end panel to worksurface.
3. Determine whether end panel will be left or right. Relocate glides as needed.
4. Place end panel smooth side down, glides closest to you.
5. Locate pre-drilled holes for attaching end/panel surface brackets. Secure end panel/surface brackets to end panel using #10x½" screws. (Figure B).

Note: Hole patterns differ for full end and half end panel.

Figure A

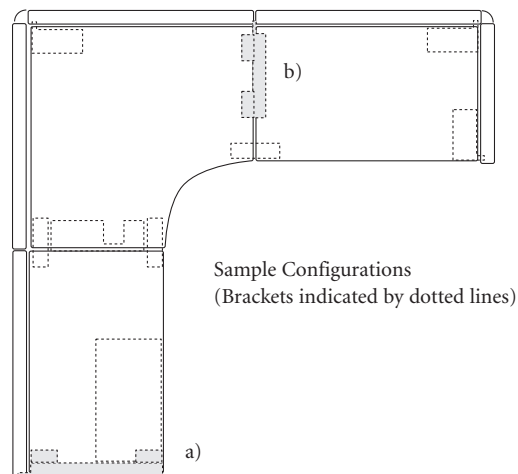
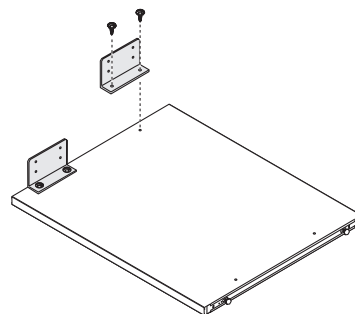

Figure B



Footprint

Installation - End Panel/Side Rail Tie Brackets

1. Two reversible end panel/side rail tie brackets secure end panel to panel side rail.
2. Rear of end panel is open to accept two tie brackets. A notch in the opening corresponding to the width of the tie bracket. Internal structure of end panel has threaded nuts for installation of tie brackets.
3. Locate notches in rear of end panel. Insert bracket, hooks facing away from rear of end panel, flush against the notch at the rear of the end panel.
4. Using a minimum of 6" magnetic Phillips tip bit/screwdriver, secure brackets to end panel using $\frac{1}{4}$ "-20 screws, provided. (Figure C).

Figure C

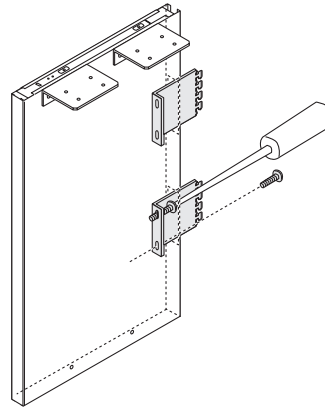

Installation End Panel to Panel, Worksurface

1. Place end panel in desired location and insert hooks on brackets into panel side rail. (Figure D). Hooks are designed to engage the side rail slots in the "up" position; extend End Panel glides to secure End Panel.
2. Place worksurface on top of End Panel. Square and level, readjusting End Panel glides as needed.
 - Front edge**—worksurface should be slightly recessed from front edge of panel side rail.
 - Rear edge**—surfaces are flush against the panel.
3. You may or may not want to secure End Panel to surface just yet, depending on other brackets and undersurface storage being installed.

Tip: All surfaces should be in place, squared and level before you screw in brackets to surfaces. This makes any minor adjustments easier.

Note: When undersurface storage is installed adjacent to End Panel, storage and End Panel may be secured to worksurface at the same time through aligned holes in storage and End Panel/Surface Brackets. (Figure E).

4. Secure End Panel/Surface Brackets to worksurface using (four) #10x1" screws provided per bracket.

Figure D

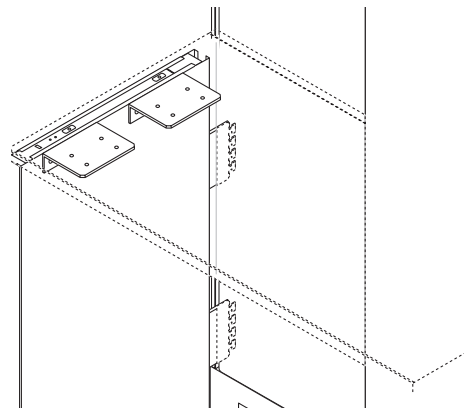
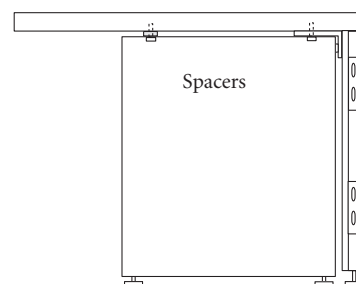

Figure E

(Rear view)



Footprint

Installation - One end panel to support two workspaces

1. Additional set of End Panel/Surface Brackets is required.
Contact Customer Care to order.
2. Install all (four) End Panel/Surface Brackets to End Panel, two per side. End Panel is predrilled on one side.
To mark smooth side, measure hole patterns on pre-drilled side and transfer to smooth side. Drill holes.
3. Insert bracket, hooks facing away from rear of End Panel, flush against the notch at the rear of the End Panel.
(Figure F).
4. Place end panel in desired location and insert hooks on the brackets into panel side rail. End panel should be centered on panel hinge. (Figure G).
5. Extend End Panel glides to secure End Panel.
6. Place surfaces onto End Panel (and other installed brackets).
Ensure it is level and square.
7. Secure End Panel/Surface Brackets to surface using (two) #10x1" screws provided per bracket.

Figure F

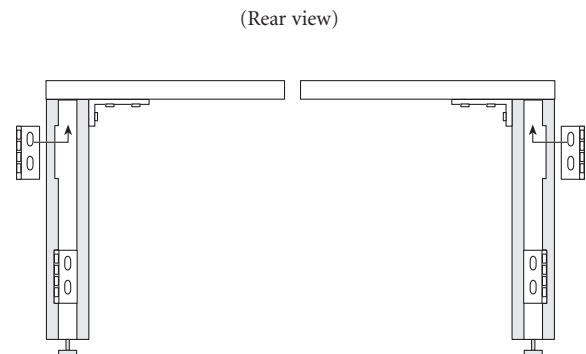
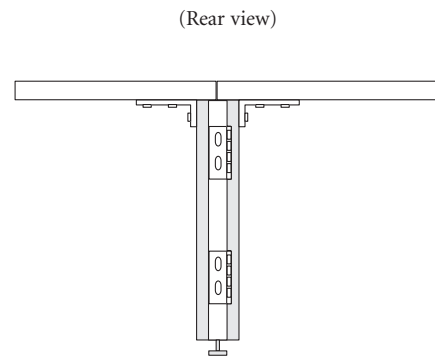

Figure G



Footprint®

Worksurface Support Panel, Return Support Panel

Tools Required

- Variable Speed Drill
- #2 Phillips Tip Bit
- Level

Package Contents

- Support Panel
- 3 #10 x 1" Phillips Particleboard Screws

General Information

- These instructions provide the basic information to install a Worksurface Support Panel or Return Support Panel onto any worksurface. (Figure A).

Installation

1. Worksurface support panel includes a filler panel. Remove filler panel by sliding up and out. (Figure B).
2. If using with gusset bracket, secure gusset bracket to support panel prior to installing to worksurface. (Figure C).
3. If using with modesty panel, secure modesty panel to support panel prior to installing to worksurface. (Figure D).
4. To install directly to surface, secure using three #10 x 1" screws, provided. (Figure E).
5. Reinstall worksurface support panel filler, if applicable. (Figure E).

Figure A

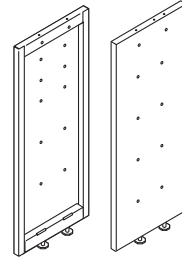
Return Support Panel
(no filler panel)

Inside Outside

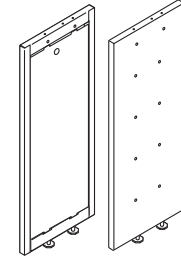
Worksurface Support Panel
(includes filler panel)

Outside Inside

Figure B

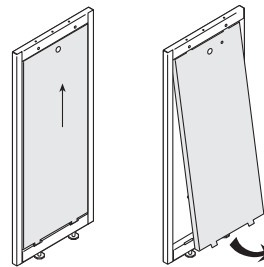

Figure C

Gusset
Bracket

Figure D



Modesty Panel

Figure E

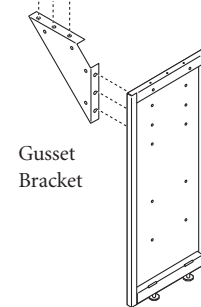
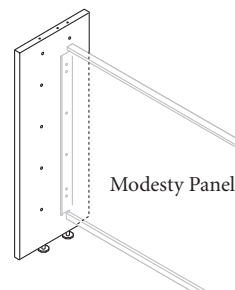
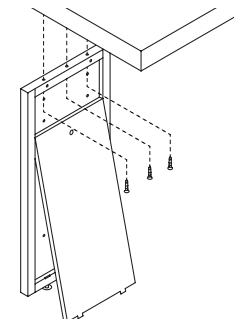

General Information

- These instructions provide the basic information to install an Interworks® End Panel, e.g. to create a freestanding desk.
- Arc worksurfaces are predrilled to accept End Panel in standard flush left/right position only.
- For Rectangular and non-standard position, worksurface must be drilled.
- Process is similar for both Full and Half End Panel. Full End Panel is illustrated.
- Half End Panel is often used to create a freestanding Corner desk.
- When an Undersurface Lateral File is used, a Full End Panel is required to support desk on the same side as the File.
- One person can perform all operations, although two may be required to handle larger, heavier units.

Tools Required

- Drill with $\frac{1}{8}$ " and #2 Phillips tip bits
- $\frac{5}{16}$ " Hex socket
- Level

Hardware

- Metal to worksurface: #10x1" Phillips pan head particleboard screws.
- Metal to metal: #10x $\frac{1}{2}$ " Hex washer head drill screws.

End Panel Installation

- End Panels include brackets for attaching to worksurface and predrilled holes to secure Modesty Panel (Figure A).
1. Determine location of End Panel, left or right. Relocate the two glides to the opposite side of support as needed.
 2. For Arc worksurface, use predrilled holes as a guide. For Rectangular worksurface, inset End Panel approximately $\frac{1}{8}$ " from front and back of worksurface, and approximately $\frac{1}{16}$ " from side of worksurface. Secure front and rear End Panel/Worksurface Brackets to worksurface with four #10x1" screws per bracket (Figure B).
 3. Turn End Panel upside down and align to installed brackets. Holes in the End Panel should be to the INSIDE and the glides should be facing UP. Secure loosely with two #10x $\frac{1}{2}$ " screws (Figure C).
- NOTE:** After you have installed the Modesty Panel, you need to retighten all screws.

Figure A

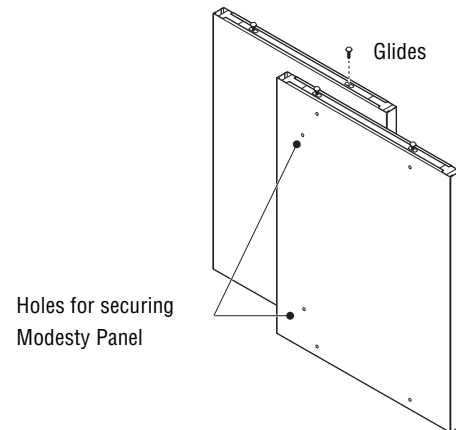

Figure B

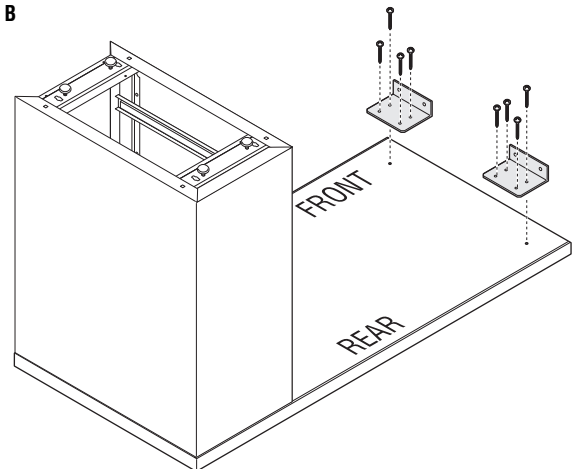
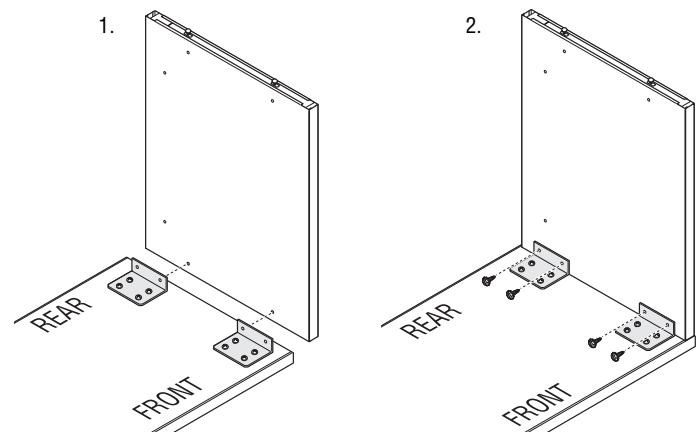

Figure C



Proper product installation, in accordance with these instructions, is the responsibility of the installing agent. If you have any questions concerning these instructions, please call your Customer Care Team.

General Information

- These instructions provide the basic information to install a Pedestal Filler Strip or Traxx Pedestal Filler Strip onto a worksurface-supporting Interworks® Pedestal (Figure A).
- Traxx Pedestal Filler Strip is non-handed; Pedestal Filler Strip is left- or right-handed (Figure B).
- Designed for use with the Interworks Pedestal and either Interworks systems or modular surface or ICS systems surface. Interworks systems surfaces are illustrated.
- When Interworks systems surface is used, a wire management gap at the rear of the worksurface occurs and may be concealed with a Wire Manager Fill Cap.
- One person can perform all operations.

Tools Required

- Drill with #2 Phillips tip bit

Hardware

- #8x³/₈" thread cutting screws

Installation

1. Filler Strip is secured to either the left or right rear of the Pedestal (Figure B).
NOTE: Pedestal Filler Strip only (panel application): Hooks engage into panel side rail and should be pointing UP.
2. Secure Filler Strip to Pedestal using six #8x³/₈" thread cutting screws, three each at the top and bottom.
3. Level Pedestal glides to set hooks in Pedestal Filler Strip or as needed. See #HAIWS002.

Figure A

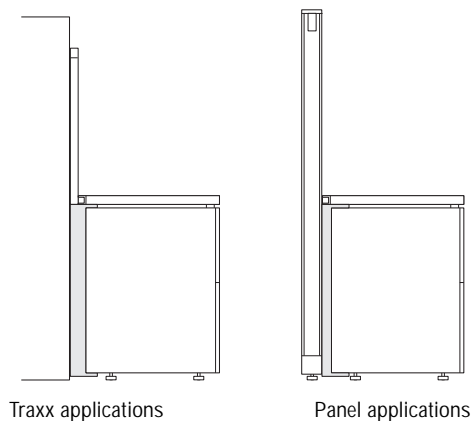

Figure B

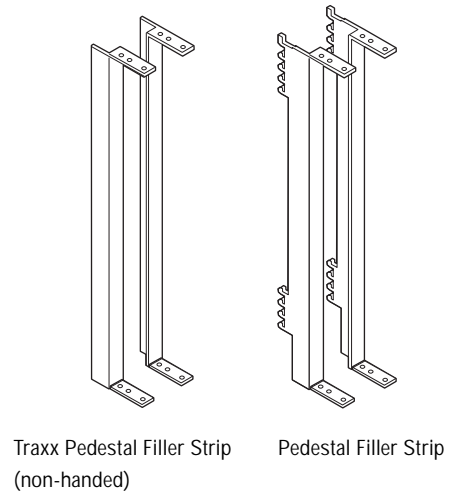
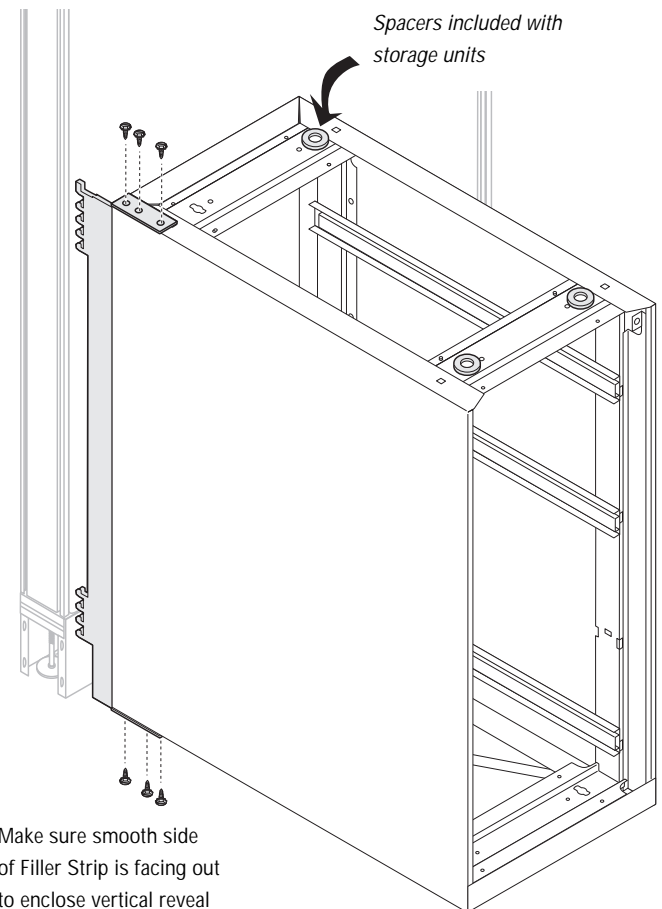

Figure C



Proper product installation, in accordance with these instructions, is the responsibility of the installing agent. If you have any questions concerning these instructions, please call your Customer Care Team.

Traxx®

Flexboard

Tools Required

- None

Package Contents

- 1 Flexboard

Installation

1. Grip flexboard firmly on each side and position in front of Traxx. (Figure A).
2. Tilt top of flexboard towards Traxx. (Figure B).
3. Insert tabs on both top brackets into the center reveal of the Traxx. (Figure C).
4. Ensure both brackets are fully inserted. (Figure D).
5. Allow bottom of flexboard to rotate inward flush against wall. (Figure E).

Note: Flexboards can also hang off the top edge of the upper Traxx, however, the anti-dislodgement feature will not engage in this position and will prevent the projection screen or marker swivel board from passing over the flexboard.

Figure A

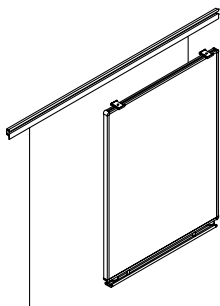

Figure B

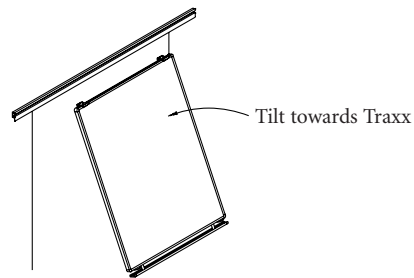

Figure C

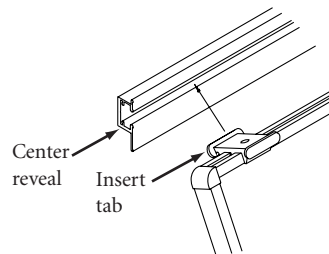

Figure D

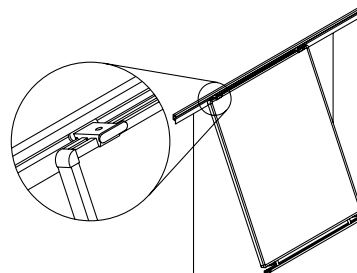
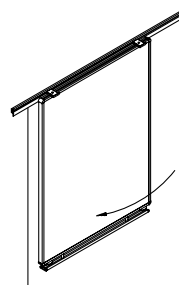

Figure E



Note: For safety, two people are required when mounting the Overhead Projection Screen or Swivel Marker Board.

Note: For clarity, in this instruction the frame is being shown without the Projection Screen or Swivel Marker Board.

TRAXX®
Assembly Instructions

**Overhead
Projection
Screen and
Swivel Marker
Board**

Recommended Tools
• None

Package Contents	Qty.
• Overhead Projection Screen	1
Or	
• Swivel Marker Board	1

1 Position screen in front of Traxx (Figure A).

Figure A

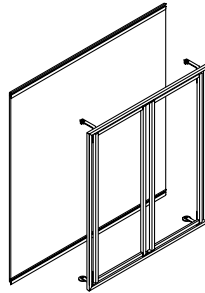

2 Tilt top of screen towards top Traxx (Figure B).

Figure B

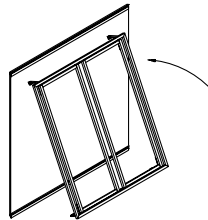

3 Hook both top brackets over the upper channel of the Traxx. Brackets must be hooked to the upper channel and center reveal for anti-dislodgement mechanism to operate correctly. Allow bottom of screen to rotate inward to normal operating position (Figure C).

Figure C

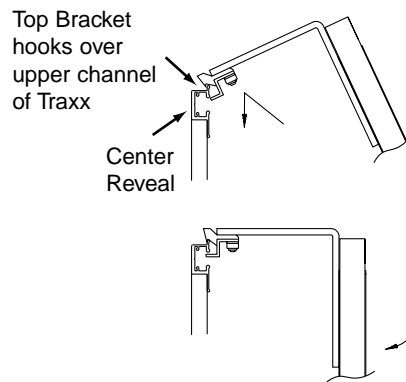

4 Ensure top brackets are seated firmly on upper channel of Traxx (Figure D).

Figure D

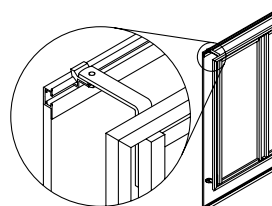

Telephone 800.482.1818
Fax 812.482.8300
www.furniture.kimball.com

Form #AISYTR003-00
#1469021

Printed in U.S.A.
© 2000 Kimball International, Inc.

Proper product installation, in accordance with these instructions, is the responsibility of the installing agent. If you have any questions concerning these instructions, please call Kimball Customer Care Teams.

Note: The frame is shown without the Projection Screen or Swivel Marker Board in these illustrations.

1 Place Overhead Projection Board or Swivel Marker Board face down on a clean, smooth, firm surface. Be careful not to puncture the face of the screen or scratch the board (Figure A).

Figure A

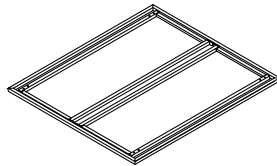

2 Attach bottom brackets to each lower corner of the frame using the provided screws and lockwashers inserted into the pre-drilled holes (Figure B).

Figure B

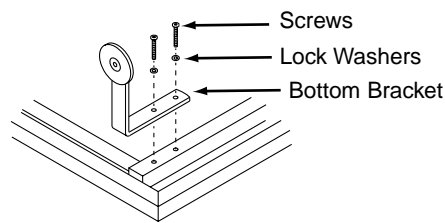

3 Tighten securely using the included Allen Wrench (Figure C).

Figure C

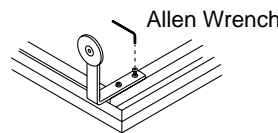

Note: Observe labels and graphics on the front of the screen or board to determine top and bottom.

4 Attach top brackets to each upper corner of the frame using the provided screws and lockwashers inserted into the pre-drilled holes (Figure D).

Figure D

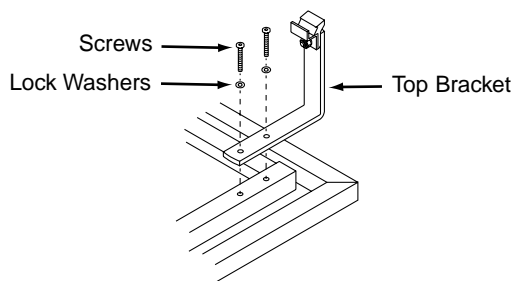

5 Tighten securely using the included Allen Wrench. Board is now ready to be installed into Traxx (Figure E).

Figure E

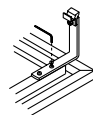

TRAXX®

Assembly Instructions

Overhead Projection Board and Swivel Marker Board Brackets

Recommended Tools

- Allen Wrench (included in package contents)

Package Contents	Qty.
• Top Brackets	2
• Bottom Brackets	2
• Lockwashers	8
• Cap Screws	8
• Allen Wrench	1



Telephone 800.482.1818
 Fax 812.482.8300
www.furniture.kimball.com

Form #AISYTR004-00
 #1469022

Printed in U.S.A.
 © 2000 Kimball International, Inc.

1 Firmly grasp Flip Chart Holder and position in front of Traxx. Tilt top of Flip Chart Holder towards rail (Figure A).

Figure A

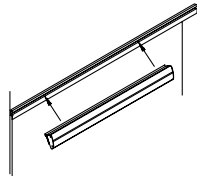

2 Insert extrusion on back of Flip Chart Holder into center reveal of Traxx. Rotate bottom of Flip Chart Holder in towards rail. Press down on Flip Chart Holder, ensuring extrusion hooks onto lower channel of center reveal of Traxx (Figure B).

Figure B

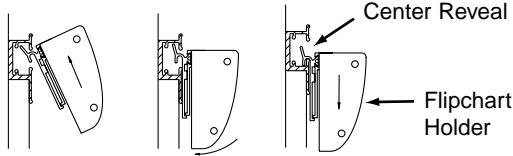

3 Press firmly along length of Flip Chart Holder to secure in locked position (Figure C).

Figure C

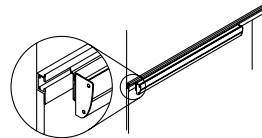

4 To mount paper onto Flip Chart Holder, rotate bottom edge of holder cover upward to open position (Figure D).

Figure D

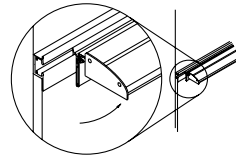

5 Reposition pegs to match holes in chart paper pad (Figure E).

Figure E

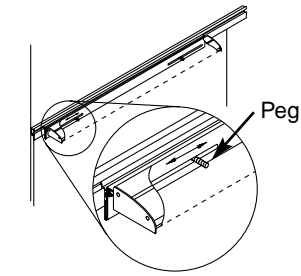

Note: If Flip Chart Holder is mounted to upper channel of Traxx, the anti-dislodgement feature will not engage and will prevent the Projection Screen or Marker Swivel Board from passing over the Flip Chart Holder.

6 Place chart paper pad over pegs. (Figure F).

Figure F

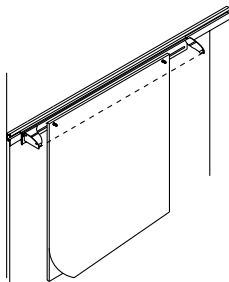

7 Rotate holder cover downward to normal operating position (Figure G).

Figure G

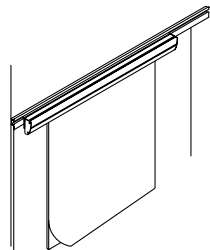

TRAXX®
Assembly Instructions

Flip Chart Holder

Recommended Tools
• None

Package Contents	Qty.
• Flip Chart Holder	1



Telephone 800.482.1818
Fax 812.482.8300
www.furniture.kimball.com

Form #AISYTR005-00
#1469024

Printed in U.S.A.
© 2000 Kimball International, Inc.

1 Grip Extendable Flip Chart Holder firmly on each side and position in front of Traxx (Figure A).

Figure A

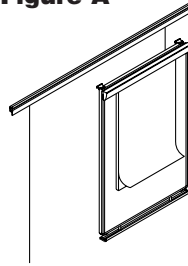
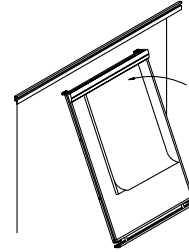

Figure B



2 Tilt top of Extendable Flip Chart Holder towards Traxx (Figure B).

3 Insert tabs on both top brackets into the center reveal of the Traxx (Figure C).

Figure C

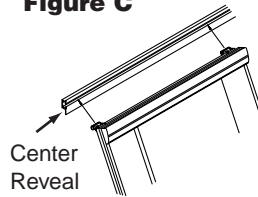
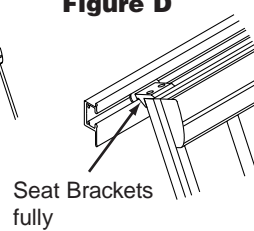

Figure D



4 Ensure both brackets are fully inserted (Figure D).

5 Allow bottom of Extendable Flip Chart Holder to rotate inward flush against wall (Figure E).

Figure E

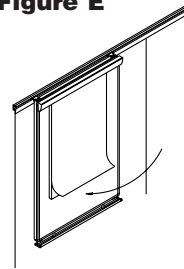
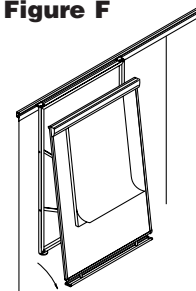

Figure F



6 To extend Flip Chart Holder from frame, grasp sides of board and gently extend (Figure F).

Grasp board and extend gently

Note: If Extendable Flip Chart Holder is mounted to upper channel of Traxx, the anti-dislodgement feature will not engage and will prevent the Projection Screen or Marker Swivel boards from passing over the Extendable Flip Chart Holder.

7 To mount paper onto Flip Chart Holder, rotate bottom edge of holder cover upward to open position (Figure G).

Figure G

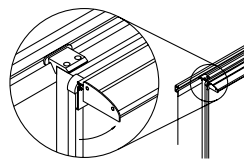
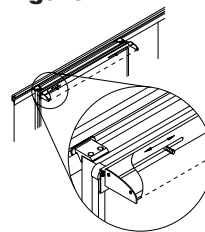

Figure H



8 Reposition pegs to match holes in chart paper pad (Figure H).

9 Place chart paper pad over pegs (Figure I).

Figure I

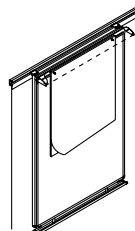
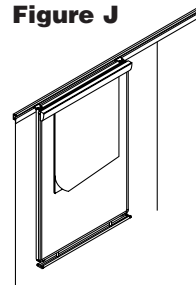

Figure J



10 Rotate holder cover downward to normal operating position (Figure J).

TRAXX®

Assembly Instructions

Extendable Flip Chart Holder

Recommended Tools

- None

Package Contents

- | Package Contents | Qty. |
|--------------------------------|------|
| • Extendable Flip Chart Holder | 1 |



Telephone 800.482.1818
 Fax 812.482.8300
www.furniture.kimball.com

Form #AISYTR007-00
 #1469020

Printed in U.S.A.
 © 2000 Kimball International, Inc.

Traxx®

Presentation Rail

Tools Required

- None

Package Contents

- Presentation Rail

Installation

1. Ensure correct position of Presentation Rail before installing. (Figure A).
2. Hook rear flange of Presentation Rail over lip in center reveal of Traxx and press down firmly to lock into position. (Figure B).
3. When aligning two rails side by side, remove the end cap from one rail and slide that rail into the end cap on the adjacent rail. Slide rails firmly together for a snug fit. (Figure C).

Figure A

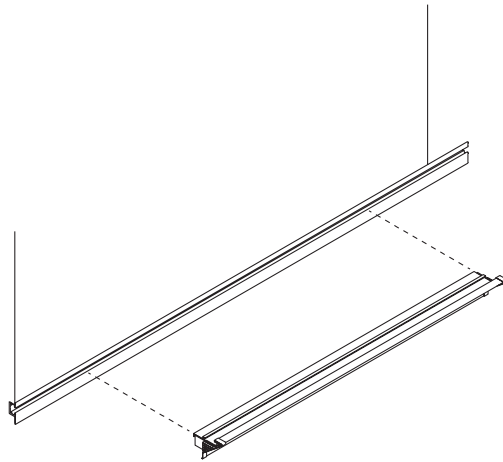

Figure B

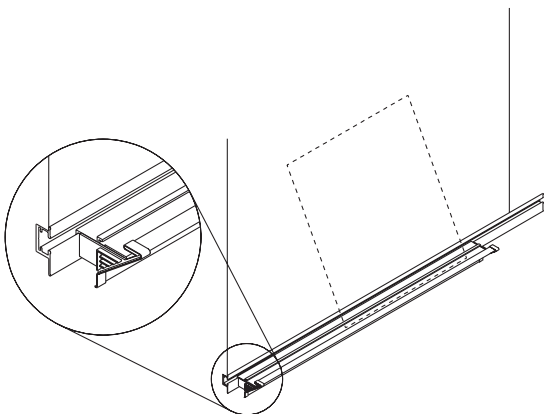
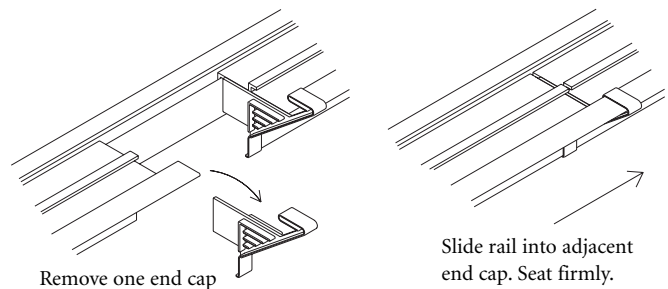

Figure C



Note: The flexboard is illustrated in this instruction.

1

Turn Flexboard upside down and place on clean, smooth surface (Figure A).

Figure A

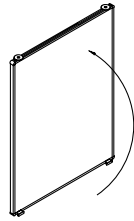

2

Insert the retainers through the large opening in the channel on the bottom of the flexboard and position one above each of the mounting holes in the bottom of the channel (Figure B).

Figure B

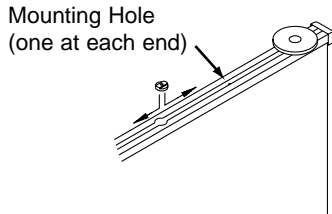

3

Hold the Penholder so the cupped side is facing the board. Insert a mounting screw through one of the mounting holes in the Penholder. Place a spacer over the screw, insert the screw through the retainer and into the mounting hole on the board (Figure C). Use the Allen Wrench to secure the Penholder to the board, but do not fully tighten at this time (Figure D).

Figure C

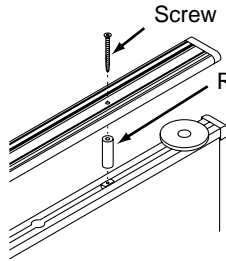
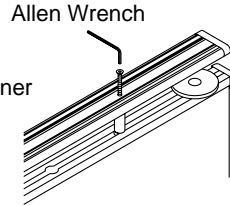

Figure D



4

Attach the other mounting screw and spacer to other end of the Penholder, ensure the screw passes through the retainer and into the mounting hole on the bottom of the board. Center the pen holder on the board, then use the Allen Wrench to fully tighten both screws on Penholder (Figure E).

Figure E

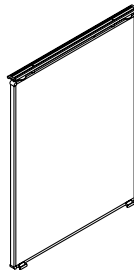

5

Turn flexboard upright (Figure F). The flexboard is ready to be installed on the Traxx.

Figure F

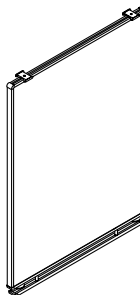

TRAXX®

Assembly Instructions

Penholder Installation

Recommended Tools

- Allen Wrench

Package Contents	Qty.
• Penholder	1
• Spacers	2
• Retainers	2
• Mounting Screws	2



Telephone 800.482.1818
 Fax 812.482.8300
 www.furniture.kimball.com

Form #AISYTR006-00
 #1469023

Printed in U.S.A.
 © 2000 Kimball International, Inc.

These instructions provide the basic information for replacing damaged or worn rollers on flexboards.

1 Invert Flexboard to expose rollers (Figure A).

Figure A

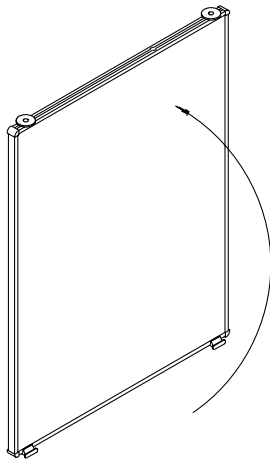

2 Drill out roller rivet using 4mm bit (Figure B). Make sure all traces of rivet are removed.

Figure B

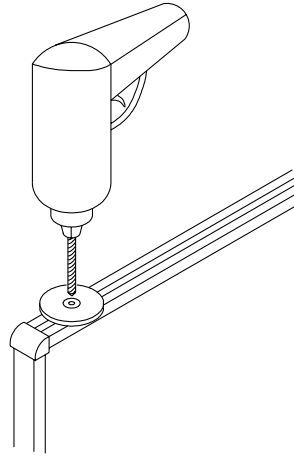

3 Insert mounting screw into replacement parts (roller, spacer, washing and bushing). Screw this assembly into drilled out hole in the flexboard channel reveal. Do not over-tighten (Figure C).

Figure C

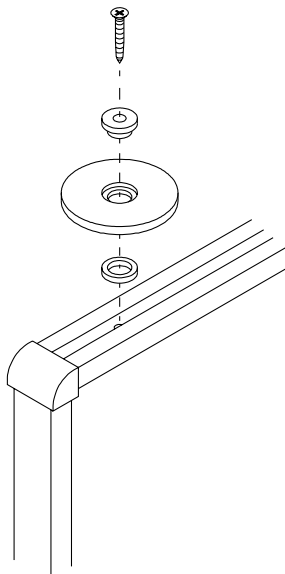

TRAXX®
Assembly Instructions

Flexboard Roller Replacement

Recommended Tools

- Power Drill
- 4mm Drill Bit
- Phillips Screwdriver

Package Contents

	Qty.
• Replacement Roller	1
• Washer/Spacer	1
• Mounting Screw	1
• Bushing	1



Telephone 800.482.1818
Fax 812.482.8300
www.furniture.kimball.com

Form #AISYTR011-00
#1469025

Printed in U.S.A
© 2000 Kimball International, Inc.

Proper product installation, in accordance with these instructions, is the responsibility of the installing agent. If you have any questions concerning these instructions, please call Kimball Customer Care Teams.

These instructions provide the basic information for installing replacement plastic corners and top brackets on the Flexboard.

1 If Top Bracket is to be replaced, remove plastic corner nearest to that bracket. Even if both Top Brackets are being replaced, only one corner needs to be removed. Use slotted screwdriver or other flat, blunt tool to gently pry edges of front and back sides of plastic corner. Use care to avoid marring finish of Flexboard frame (Figure A). If only plastic corner is being replaced, proceed to Step 6.

Figure A

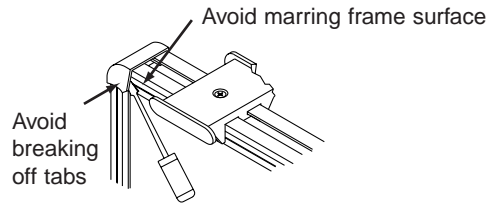

2 After corner is removed, use Phillips screwdriver to remove mounting screw from top bracket(s) (Figure B).

Figure B

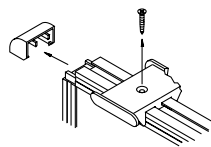

3 Slide old bracket(s) out of channel in Flexboard frame (Figure C).

Figure C

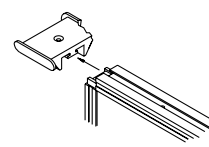

4 Slide new bracket(s) into Flexboard channel, ensuring bracket flange is inside channel reveal. Position bracket(s) over mounting hole in channel (Figure D).

Figure D

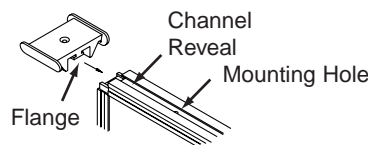

5 Use new mounting screw to attach bracket(s) to frame by inserting screw through bracket and into mounting hole (Figure E).

Figure E

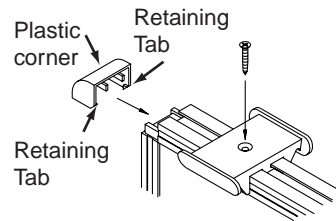

6 Replace plastic corner on Flexboard frame by gently prying out sides of corner with screwdriver on the front and back sides of frame while pushing corner into position. Avoid breaking retainer tabs off of plastic corner and use care not to mar surface of Flexboard frame (Figure F).

Figure F

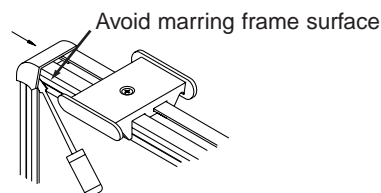

TRAXX®
Assembly Instructions

**Flexboard
Top Bracket
and
Plastic Corner
Replacement**

Recommended Tools

- Slotted Screwdriver
- Phillips Screwdriver

**Package
Contents**

Qty.

- | | |
|------------------|---|
| • Top Bracket | 1 |
| • Mounting Screw | 1 |
| • Plastic Corner | 2 |



Telephone 800.482.1818
Fax 812.482.8300
www.furniture.kimball.com

Form #AISYTR010-00
#1469027

Printed in U.S.A.
© 2000 Kimball International, Inc.

Proper product installation, in accordance with these instructions, is the responsibility of the installing agent. If you have any questions concerning these instructions, please call Kimball Customer Care Teams.

These instructions provide the basic information for installing replacement plastic corners on the Extendable Flip Chart Holder.

1 For ease of corner replacement, ensure Flip Chart Holder is fully extended out and down (Figure A).

Figure A

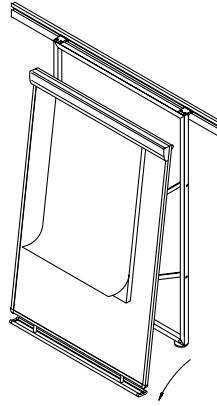

2 Use slotted screwdriver or other flat, blunt tool to remove plastic corners. Gently pry front and rear edges of plastic corner while pulling it away from Chart Holder Frame. Use care to avoid marring finish of frame (Figure B).

Figure B

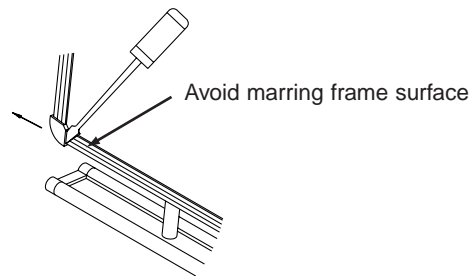

3 Position replacement corner piece on corner of frame (Figure C).

Figure C

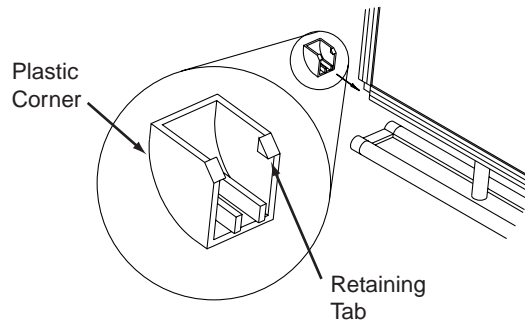

4 Use screwdriver to gently pry out sides of plastic corner on front and back sides of flipchart holder frame while pushing corner into position. Avoid breaking retainer tabs off of plastic corner and use care to not mar surface of holder frame (Figure D).

Figure D

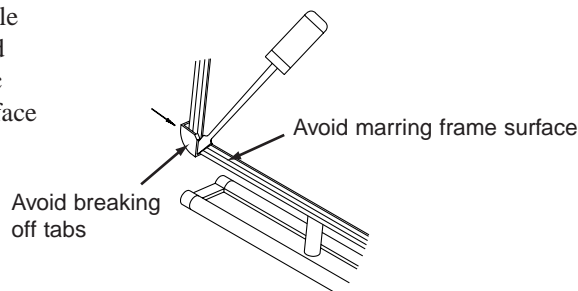

TRAXX®
Assembly Instructions

**Extendable
Flip Chart
Holder
Plastic Corner
Replacement**

Recommended Tools

- Slotted Screwdriver

**Package
Contents**

- Plastic Corner **Qty.** 2

Kimball®
Office Furniture

Telephone 800.482.1818
Fax 812.482.8300
www.furniture.kimball.com

Form #AISYTR012-00
#1469026

Printed in U.S.A.
© 2000 Kimball International, Inc.