

Fastener Concealment

Tools Required

- Screwdriver or other blunt, thin object
- Scissors

Package Contents

- 1 Fastener Concealment (60' Roll)

Installation

1. Begin installation of fastener concealment by squeezing end into a "V" shape and place into the center reveal lower groove of Traxx. Press upper portion of concealment into groove. Continue installation ensuring the vinyl concealment stays in lower groove. Felt concealment is mounted into the center reveal, but does not need to be placed in the lower groove. (Figure A).
2. Use your finger or any blunt, thin object to push the fastener concealment securely into the center reveal. Be careful not to scratch the Traxx. Continue to insert the fastener concealment the length of the Traxx channel. (Figure B).
3. At the end of the Traxx run, use scissors to cut fastener concealment to required length. Cut vinyl fastener concealment 3" longer than Traxx to compensate for any stretch and recoil.

Figure A

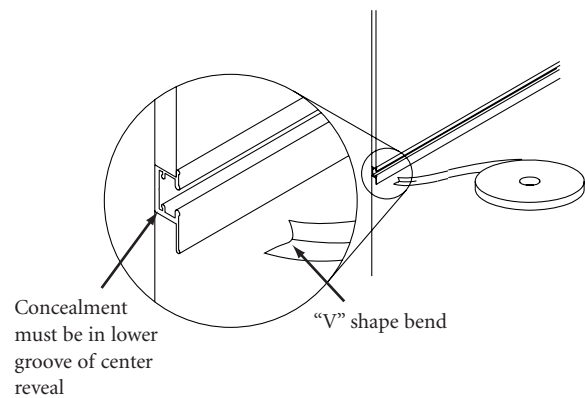

Figure B

