

# Footprint®

## Lunar Overhead Storage Cabinet Ganging Bracket for Xsite®/Traxx®

### Tools Required

- Electric Drill/Driver
- Rubber (non-marring) Mallet
- #3 Phillips Head Bits

### Package Contents

- 1 Ganging Bracket
- 2 #10 x 1/2" Self-drilling Phillips Panhead Screws

### Installation

**Note:** This instruction covers installation of ganging brackets for all Lunar cabinetry assembled and installed on Xsite and Traxx only. All operations to assemble the cabinet and doors can be done by one person, but it is recommended that two people install the units to the panel system/Traxx.

**Important:** This instruction explains basic Lunar ganging bracket assembly techniques. Please see assembly instruction "Lunar Overhead Storage, Flipper Door Cabinet" for basic cabinetry assembly and installation to panel systems as needed.

### Purposes of the ganging bracket:

- To align the front lower edge of the adjacent cabinet.
- To add rigidity to the installed cabinets.

**Pre-installation action:** As mentioned above, reference assembly instruction "Lunar Overhead Storage, Flipper Door Cabinet" to assemble all cabinetry and install it to Xsite panels and/or Traxx. Take care to not damage the unit(s) or the panel. Inventory the package contents before proceeding with assembly/installation. Stop if there are insufficient items to complete the assembly.

1. Figure A shows a single door Lunar overhead cabinet for reference.
2. Figure B shows a typical side-by-side application for ganging on an Xsite panel run.

Figure A

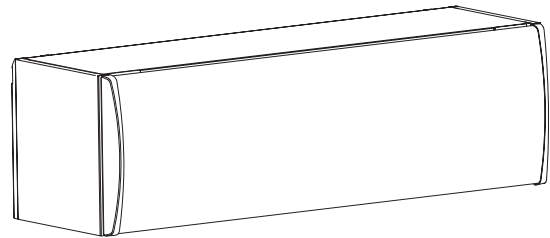
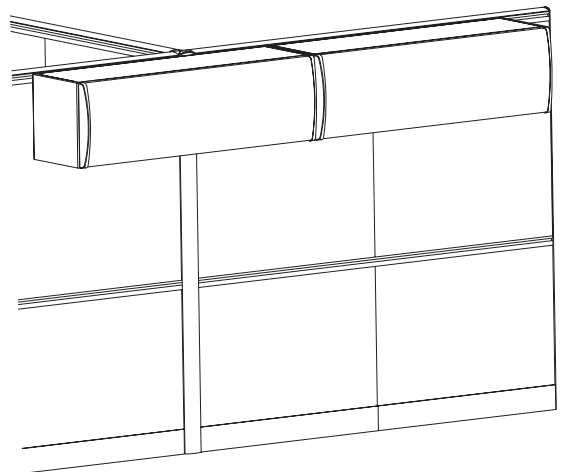

Figure B



# Footprint

## Installation (continued)

3. Position the cabinets in their leveled and desired location.  
To slide cabinets right or left, lift the lower front edge of each cabinet, thus lifting the cabinet away from the panel face(s). Open the cabinet doors and fully slide them back. Press the adjacent cabinets together by pushing horizontally and slightly lifting the front edge of each cabinet. The cabinet ends must be in direct contact with no gaps. (Figure C).
4. Continue pushing and slightly lifting the cabinets. Loosely position the ganging bracket under the lower front flanges of the cabinet so that the vertical “ears” of the ganging bracket are directly behind the edge of the lower front shelf flange. (Figure D).
5. With the ganging bracket in position, press the bracket upward to its final fully-seated position. Significant pressure will be required as the bracket “ears” are intended to grip the interior end panels of the cabinet, aiding in positioning/holding power of the assembly. A rubber non-marring mallet may be needed to fully seat the bracket. (Figure E).

Figure C

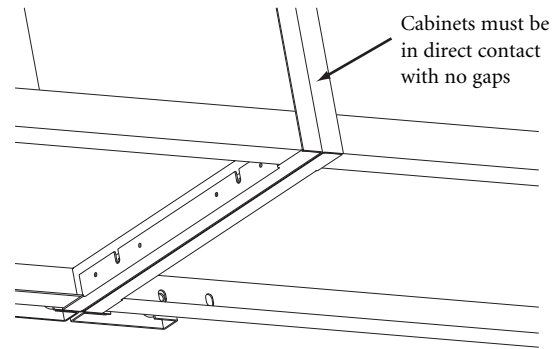

Figure D

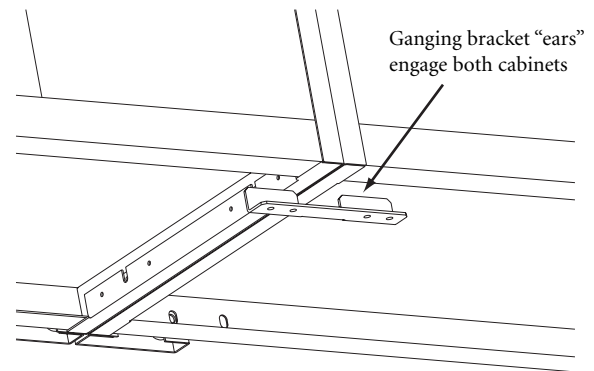
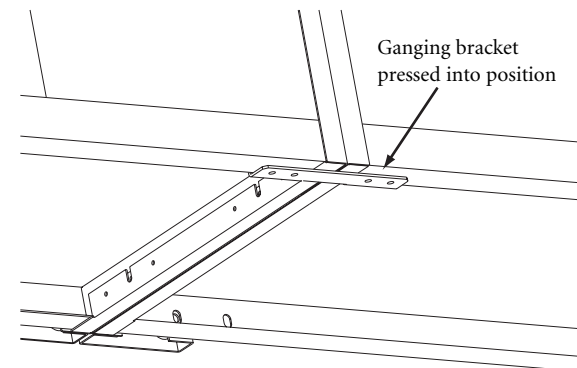

Figure E



# Footprint

## Installation (continued)

6. Continue pushing and slightly lifting the cabinets. Install the self-drilling screws into either of the holes, one per side, in the lower flange of the ganging bracket, drilling directly into the lower flange of the cabinet shelf. Two holes per side are provided in case the initial attempt at screw installation fails and will allow a second try without having to field drill the ganging bracket. To obtain the best grip, angle each screw outward from the center of the bracket, which positions each screw to the most outward edge of its hole in the bracket. This forces the edge of the bracket hole to be in direct contact with the screw thread as it is engaged, thus not allowing slippage. (Figure F).
7. After all screws are firmly installed, lower cabinets down to their normal position. Re-check that the front, lower edges of the cabinet end panels are in alignment and are in direct contact with no gaps. (Figure G).
8. Close cabinet doors. Per previous assembly/installation instructions, re-check all door and lock operation.

Figure F

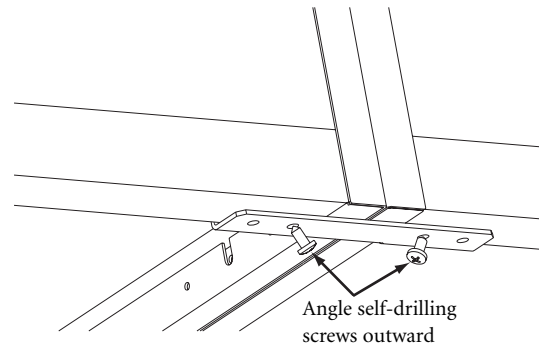

Figure G

