

Fundamental[®], LF Series[®]

General Setup

Tools Required

- Flat Head Screwdriver
- Phillips Head Screwdriver
- Hammer and Punch
- Level
- #8-32 3/8" Hex Socket Nut Driver

General Information

- These instructions provide the basic information to do the following in any Fundamental, LF Series: remove and reinstall drawers, and gang units.
- Fundamental ADA File only: Screw-on pulls are packaged inside drawer to prevent damage. Assemble using hardware provided.
- One person can perform all operations although two may be required to position larger units.

Installation

Removing Drawers

1. Fully extend drawer (Figure A).
2. While gripping and lifting near the top edge of the drawer side, hand strike the drawer side just above the extended slide to release the front locking tab (Figure A).
3. Repeat this procedure at the rear of the drawer side.
4. Support the released end of the drawer with one hand placed beneath the drawer center.
5. Strike the opposite drawer side to release each of the locking tabs.
6. Lift drawer from slides.

Figure A

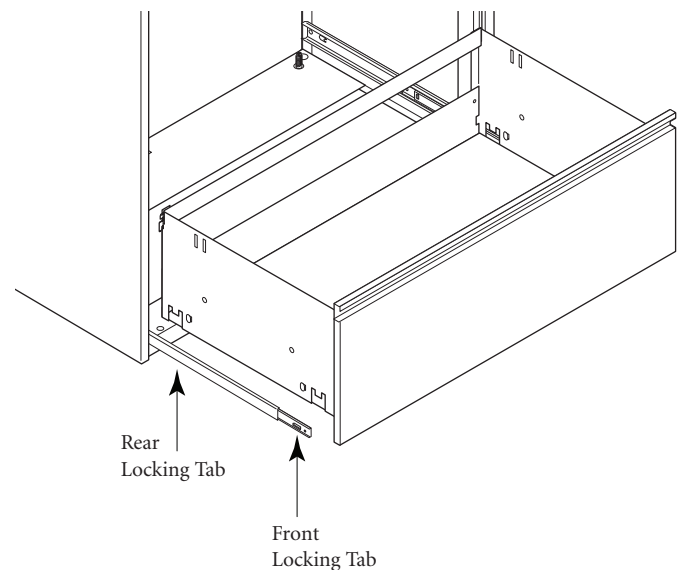

Fundamental[®], LF Series[®]

Installation (continued)

Leveling Cabinet / Adjusting Glides

LEVELING IS CRITICAL. ALL FILES MUST BE LEVELED.

- Bottom drawer must be removed.
 - If file is heavily loaded, it may be necessary to remove additional drawers in order to adjust glides accurately.
1. Locate the four glides at each inside corner of the cabinet (Figure B).
 2. With level on top of cabinet, adjust glides by inserting flat head screwdriver into glide cutout (Figure B). Turn screw driver clockwise to raise cabinet; turn counter-clockwise to lower cabinet.

Ganging Units

- Top drawers must be removed to provide access to inside of cabinet.
 - Units must be the same height.
 - Knockouts are provided along top sides (one) of file.
1. Using hammer and punch, remove appropriate knock-outs from the outside in.
 2. Bolt together through knock-outs (Figure C). Hardware not provided.

Reinstalling Drawers

Replace drawer by reversing procedure in “Removing Drawers.”

1. Fully extend slide from cabinet.
2. Align vertical tabs at front and rear with horizontal slot in slide and move front of drawer down until both locking tabs snap in place (see Figure D).

Figure B

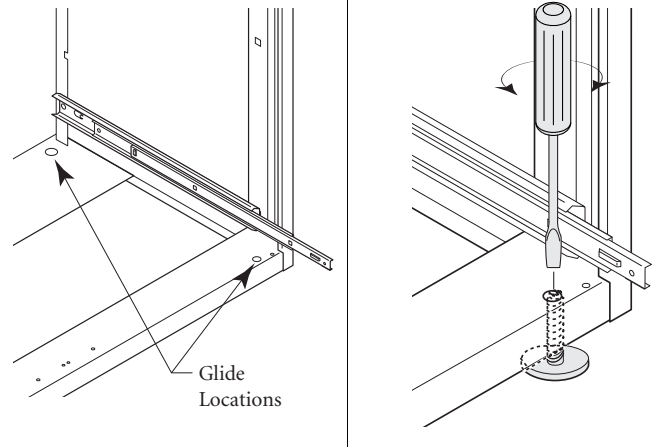

Figure C

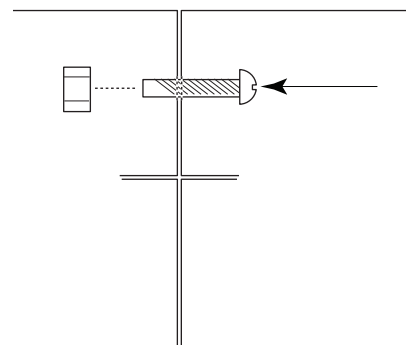
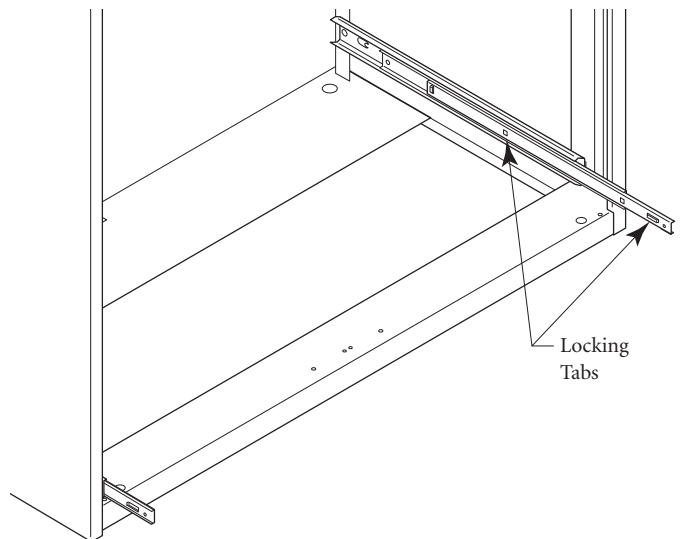

Figure D



Printed in U.S.A. © 2010 Kimball International, Inc. T 800.482.1818 F 812.482.8300

Proper product installation, in accordance with these instructions, is the responsibility of the installing agent. If you have any questions concerning these instructions, please call Kimball Office Customer Service.

Kimball[®]Office