Perks[®]

Assembly Instructions

2066779 Revision A-10

Complete Series Master Packet

Proper product installation, in accordance with these instructions, is the responsibility of the installing agent.
If you have any questions concerning these instructions, please call Kimball Office Customer Service.

Mobile Screens

Tools Required

- Hex Head Wrench
- Rubber Mallet

Package Contents

- | | |
|--|---|
| For Starter Screen: <ul style="list-style-type: none"> ■ 1 Starter screen ■ 2 Casters | For Add-on Screen: <ul style="list-style-type: none"> ■ 1 Add-on screen ■ 2 Handcuffs ■ 2 Handcuff screws ■ 1 Caster |
|--|---|

Installation

Note: A basic Screen Assembly consists of a Starter Screen (2 casters) and an Add-on Screen (1 caster) as a minimum.

- Place a Starter Screen and an Add-On Screen side by side on a clean, solid surface or floor; protect screen tubes from marks and scratches. (Figure A).
- Place the two sections of the handcuff around the adjacent top collars at the top of the screen tubes and fasten together with the handcuff screw as shown. (Figure B). Repeat procedure for lower connecting collars located above the casters.

Note: Additional Add-On Screens may be attached to the basic assembly by repeating Step 2.

Note: Over-tightening of the handcuff screws may constrain the folding capability of the mobile screens.

- Insert casters into sockets in the bottom of the screen tubes. Make sure caster fully seats in socket. If necessary, use a rubber mallet to seat caster. **DO NOT** strike caster with any other hard object. (Figure C).

Note: Each Starter Screen must have 2 casters inserted.

Use 1 caster with each add-on screen. There should be only one caster at each screen connection.

- Stand assembled unit upright. For safety and stability, make sure position of screens does not exceed 115°. (Figure D).

Figure A

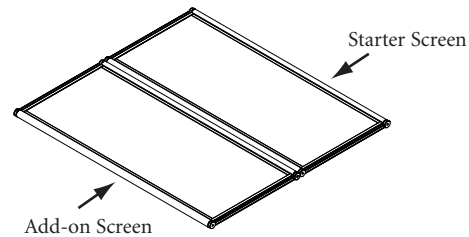

Figure B

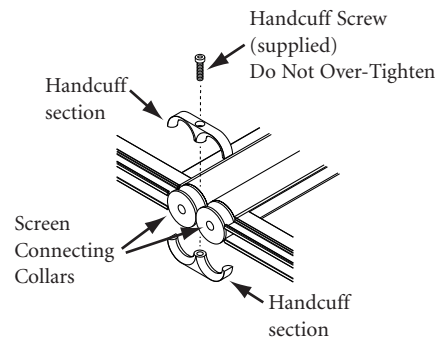

Figure C

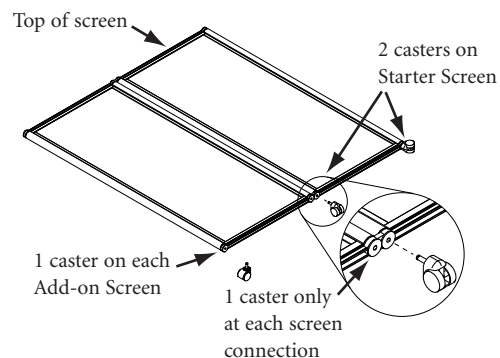
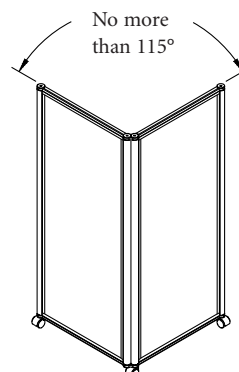

Figure D



Carousel Tray

Tools Required

- Drill
- Phillips Head Screwdriver
- 1/8" Bit and 1/2" Socket

Package Contents

- Carousel Tray
- 1 Standard Washer
- Mounting Plate
- 1 Lock Nut
- 4 #8 x 3/4" Flathead Screws
- Roller Catch Assembly
- 2 #8 x 1 1/2" Panhead Screws

General Information

- These instructions provide the basic information to install a Carousel Tray onto any worksurface.

Installation

Carousel Tray:

1. Position mounting plate 1" from front edge of worksurface in desired location. (Figure A).
2. Secure bracket with four flathead screws provided.
3. Align hole in tray over threaded stem on mounting plate.
4. Assemble washer then lock nut and tighten with 1/2" socket.

Roller Catch:

Note: Roller catch stabilizes carousel tray at rear, preventing it from unintentional free-rotation, e.g. if accidentally bumped.

1. Align Carousel Tray with front edge of worksurface. Position roller catch inside depression at center back of tray. (Figure B).
2. Mark worksurface through holes in bracket. Drill two pilot holes and mount bracket to worksurface with two 1 1/2" panhead screws provided.

Figure A

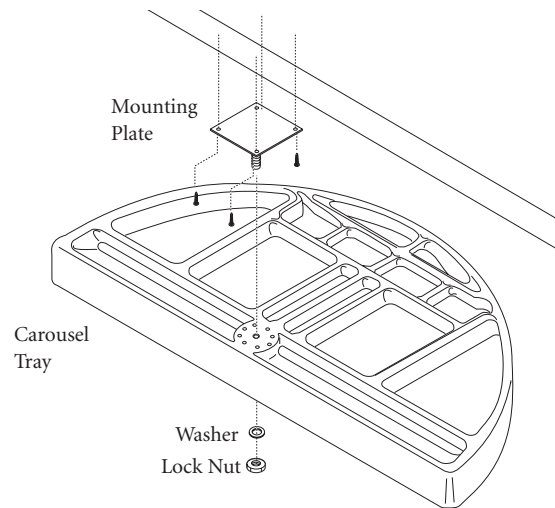
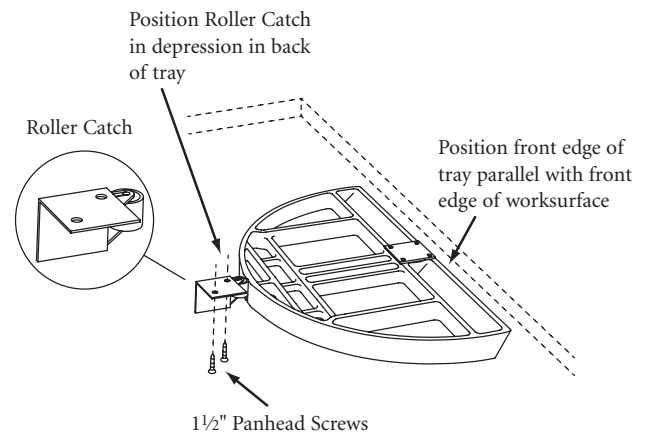

Figure B



Center Drawer

Tools Required

- Drill
- Phillips Head Bit
- Tape Measure or Ruler
- Pencil

Package Contents

- Center drawer with two slides
- 4 Screws

Installation

1. Locate center drawer by setting back $\frac{1}{4}$ " from front edge of worksurface at the desired location. (Figure A).
2. Hold center drawer in place and mark the locations for the slide screws on the underside of the worksurface.
3. Attach drawer in marked locations using screws provided.

Note: Center drawer cannot be used under a 24"D worksurface when using a modesty panel.

Figure A

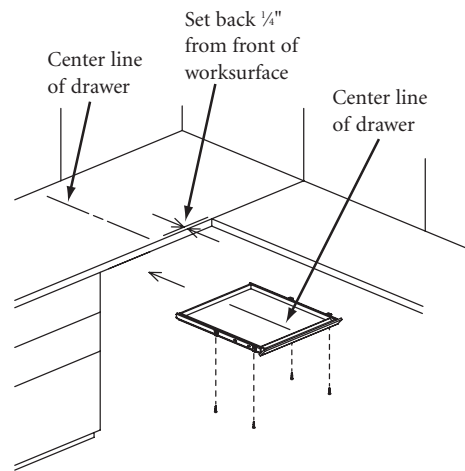

Hanging Marker Tile

Tools Required

- None

Package Contents

- 1 Eraser Tray
- 1 Hanging Marker Tile

Installation

1. Lay Hanging Marker Tile on a solid surface. (Mounting brackets on the back of the tile should be at the top). Ensure face of marker tile is clean and dry. (Figure A).
2. Peel off pre-mounted adhesive tape backing. (Figure B).
3. Ensure tray is in upright position (curved edge of tray pointing up). Align bottom and side edges of tray with edge of marker tile. Do not attach any part of the tray to the tile frame. Press tray firmly onto face of tile. (Figure C).

Figure A

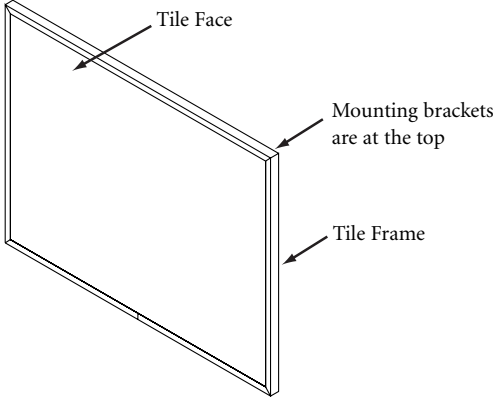

Figure B

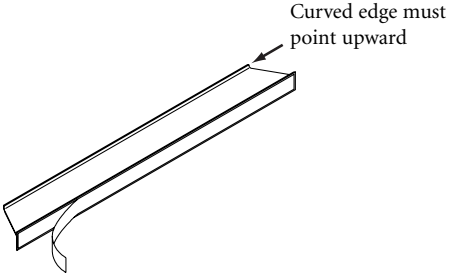
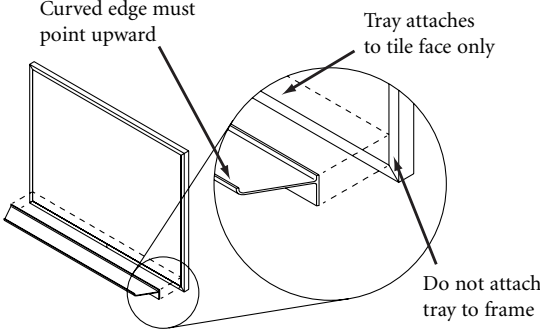

Figure C



Printed in U.S.A. © 2007 Kimball International, Inc. T 800.482.1818 F 812.482.8300

Proper product installation, in accordance with these instructions, is the responsibility of the installing agent. If you have any questions concerning these instructions, please call Kimball Office Customer Care.

Kimball®Office

Wall Mount Markerboard or Tackboard

Tools Required

- Tape Measure
- Level
- Phillips Screwdriver
- Drill

Package Contents

- 1 Markerboard or Tackboard
- 1 Pencil Tray (Markerboard only)
- 1 Wall Mount Bracket
- 5 #10 x 1" Truss Head Phillips Sheet Metal Screws (Markerboard only)
- 4 1½" Screws for Marker Tray

Installation

1. Lay board face down on a smooth, solid surface and remove shipping screw that is holding wall mount (shorter) portion of bracket to board. (Figure A).

Note: Fasteners needed to attach wall mount bracket to wall are **NOT** included.

See chart at right for recommended fasteners.

Figure A

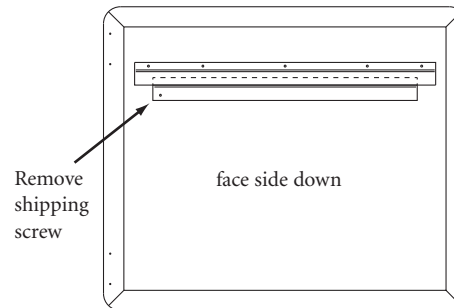

Wood Studs

For 2" x 4" wood studs or greater:
#10 x 2" screws

Metal Studs

For 20 gauge metal studs or heavier:
1. #7 x 1¼" Phillips Flathead self-starting screw for ¾" drywall;
2. #7 x 1½" Phillips Flathead self-starting screws for ½" or ¾" drywall

Concrete or Block Wall

1. ¼" toggle bolts;
2. ¼" - 20 expansion anchors;
3. STAR ¼" short lag screw expansion shields;
4. Vinyl screw anchors for ¼" lag bolts and #12 x 1½" screws

Installation (continued)

- Position wall mount bracket on the wall at desired location. At least two studs must be used for support with wood or metal stud mounting. (Figure B). Ensure bracket is level. Drill pilot holes required for fasteners thru bracket $\frac{1}{2}$ " from bottom edge of bracket. For wood or metal stud mount, use one fastener at each stud. (Figure B).

For concrete or block wall mount, it is recommended a fastener be placed 2" from each end and in the center. (Figure C).

- Attach the pencil tray to the front of the board using the four $1\frac{1}{2}$ " screws provided. (Figure D).
- Hold the board securely and slip the lower edge of the mounting bracket over and behind the upward protruding lip of the wallmount bracket. Then slide the board down to lock it into position. (Figure E).

Figure B

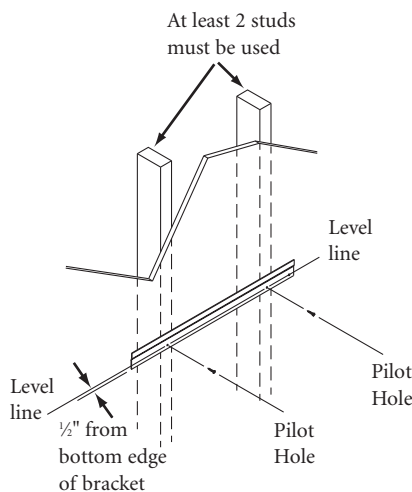

Figure C

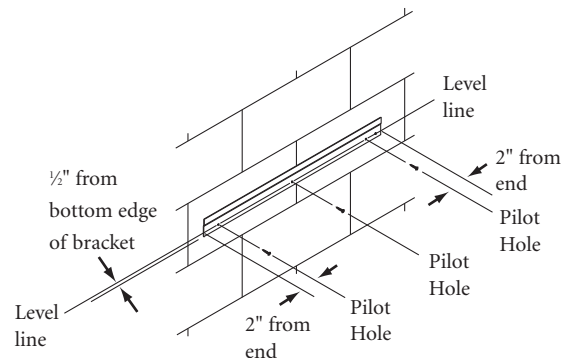

Figure D

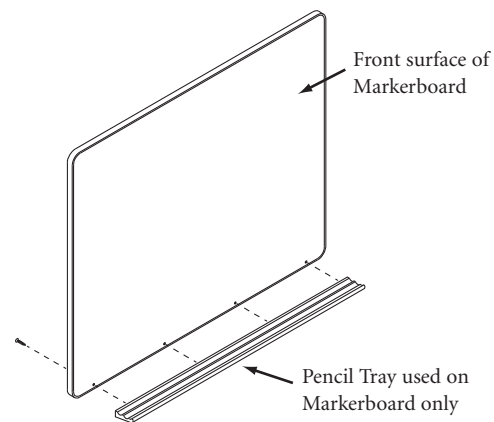
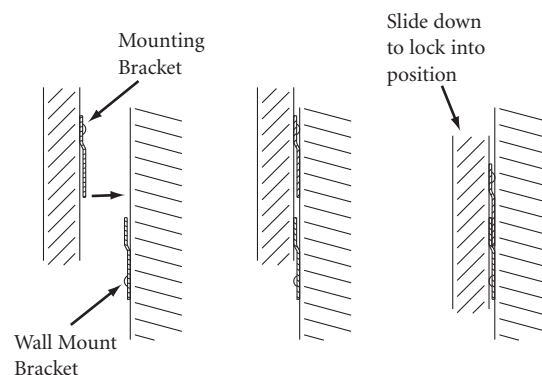

Figure E



Proper product installation, in accordance with these instructions, is the responsibility of the installing agent. If you have any questions concerning these instructions, please call Kimball Office Customer Service.

Kimball®Office

Work Tools Bumper Placement

Tools Required

- None

Package Contents

- Peel-off Bumpers

Installation

Note: The rubber bumpers are intended for use on Work Tools when they are hung on Xsite® TRAXX®, Traxx or slat tile.

1. Peel the rubber bumpers from their adhesive backing and firmly affix them to the rear of the work tool. If the work tool is to be placed on a worksurface, affix a bumper near each corner of the bottom of the work tool. (Figure A).
2. When the work tool is being hung on Xsite Traxx, Traxx or slat tile the rubber bumpers should be located within $\frac{3}{8}$ " of the bottom of the work tool hanging flange. Space the rubber bumpers evenly across the width of the work tool. (Figure B).

Figure A

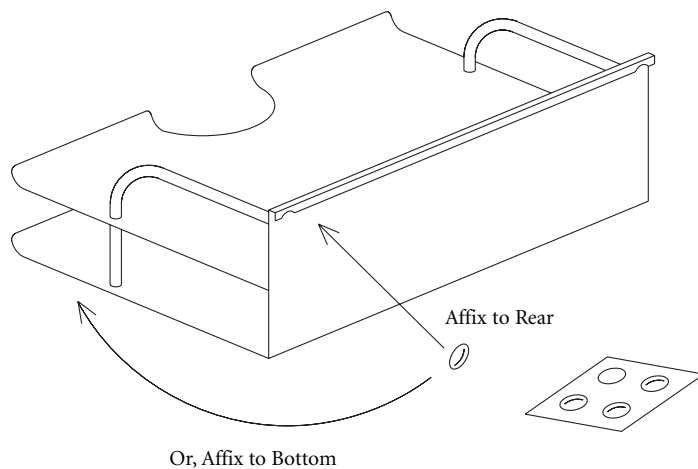
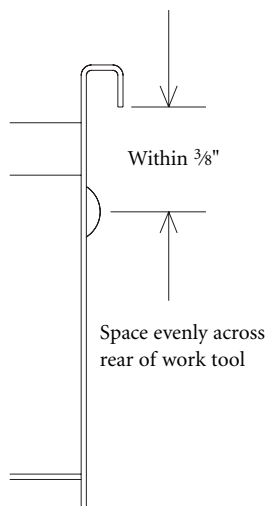

Figure B



Intuitive Adjustment Monitor Arm Attachment

Tools Required

- None

Clamp Mount Installation

Important: Holds a single monitor up to 20 lbs. For use only on the straight edge of a worksurface; not applicable for Knife, reverse Knife, and slope edges.

1. Remove Bottom Assembly from Base by loosening screws with hex key. (Figure A).
2. Position Base at surface edge. (Figure B).
Note: If Clamp is installed along wire manager edge of work surface, the bottom edge of the wire manager will need to be notched. (Figure C).
3. From under surface, reattach Bottom Assembly. Tighten screws and clamp Disk Screws with hex key to secure. (Figure D).
Note: Proceed to Step 12 Attach VESA Bracket to monitor.

Figure A

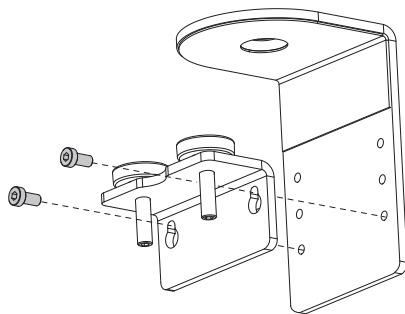

Figure B

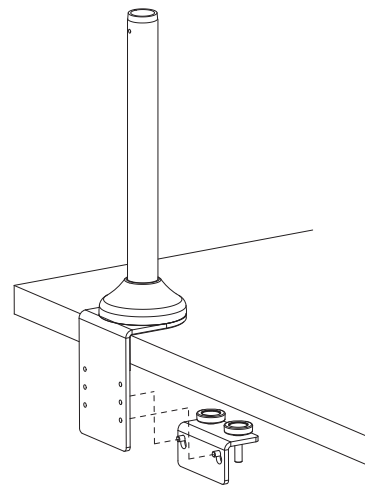

Figure C

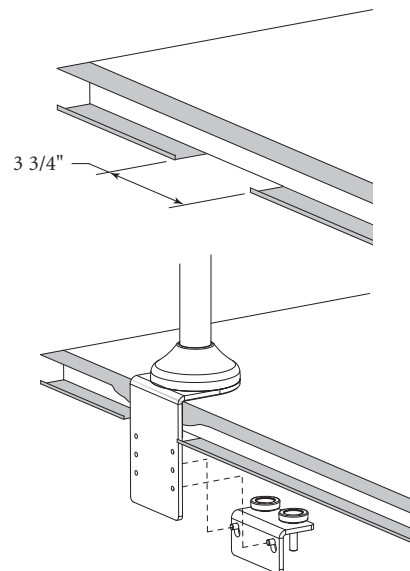
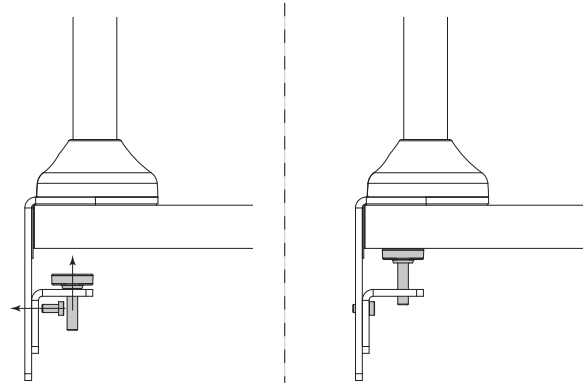

Figure D



Slat Mount Installation

Important: For use only on metal slat tiles, 24" and 30" with Cetra Slat Tiles, and 18", 24", or 30" with 1-high or 2-high Xsite Slat Tiles. 2-High Xsite slat tiles require an extra mid-frame support for stability, specified separately. One monitor arm per slat tile.

- Loosen set screws with hex key and slide bracket into grooves on slat wall. (Figure E).
- Tighten set screws with hex key until the brackets are securely fastened to the slat wall. (Figure E).

Note: Proceed to Step 12 Attach VESA Bracket to monitor.

Bolt-Through Mount Installation

Important: Cannot be used with 1 9/16" worksurface or placed over a pedestal, modesty panel, or support panel.

- Drill 1/2" hole through surface in desired location.
- Apply protective foam sheet to bottom of base if desired.
- Pass large bolt through hole in curved plate. Make sure to note the direction of the curve. Pass bolt through hole in surface and screw into vertical assembly (pole). (Figure F).
- Verify that the small hole at the top of the pole is facing away from the user and then tighten large bolt with provided hex key.

Note: Proceed to Step 10 Attach Arm to Mounting Post and to Step 12 Attach VESA Bracket to monitor.

Arm to Mounting Post Installation

- Align groove in Arm Post with Screw on Mounting Post and slide Arm Post into Mounting Post. (Figure G).
- Secure with screw.

Figure E

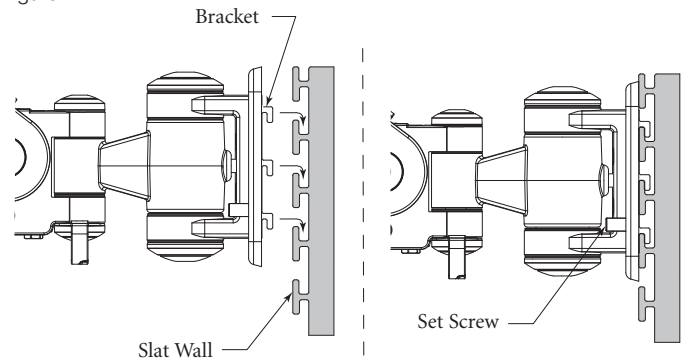

Figure F

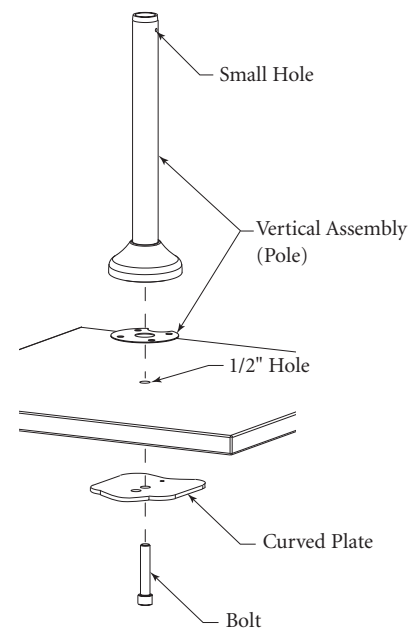
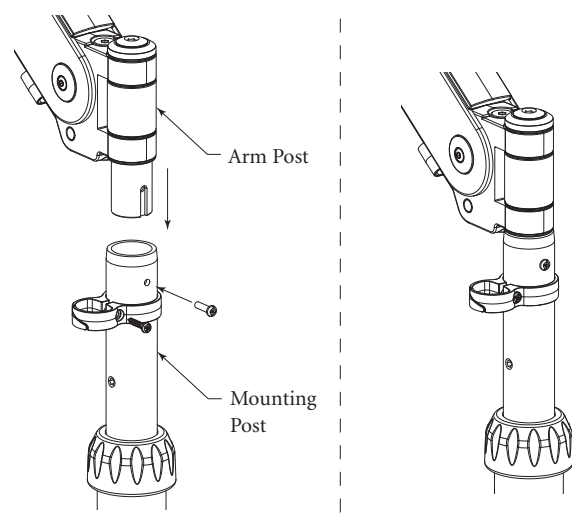

Figure G



VESA Bracket to Monitor Installation

12. Select 75mm or 100mm VESA Bracket to match hole pattern on back of monitor.
13. Place VESA Bracket in position on back of monitor with cut-out toward top of monitor and attach using screws provided. For this you may also use screws that came with your monitor. (Figure H).

Important: Monitor should not exceed 20 lbs.

Monitor to Mounting Arm Installation

14. Place cut-out on VESA Bracket over Lip at end of Arm. Secure monitor to arm using two (2) screws. (Figure I).

Cable Management

15. Route the monitor and power cables through clips as shown. The clip for the pole must be opened and slipped over the pole and then secured with the supplied screw to the desired height as indicated. (Figure J).

Figure H

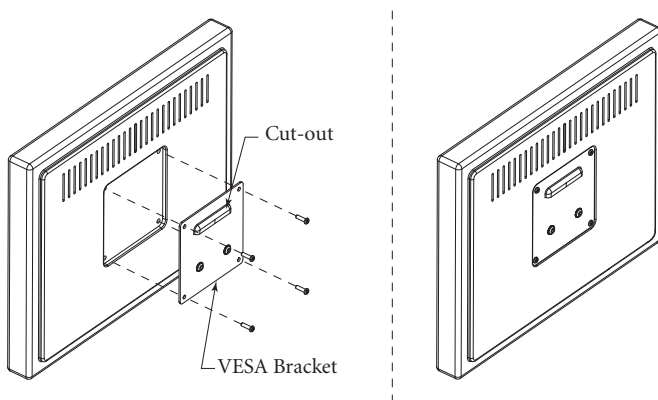

Figure I

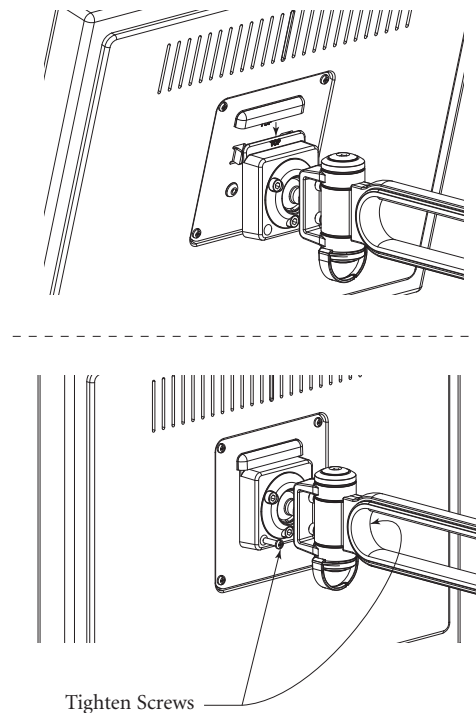
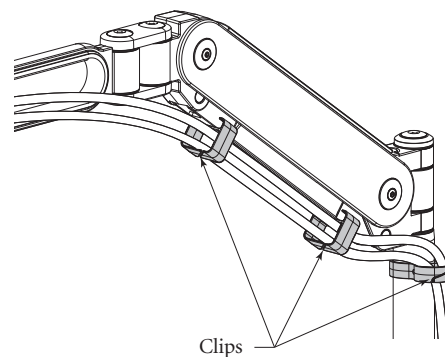

Figure J



Friction Adjustments

16. If desired, friction on the Ball Joint may be increased. This can be achieved by tightening the three (3) Ball Joint Friction Screws. (Figure K).
17. Adjust the Tension Screw to increase or decrease the strength of the arm to balance the weight of the monitor. Turn the Screw clockwise to decrease tension (for smaller monitors) or counter-clockwise to increase tension (for larger monitors). (Figure L).

Figure K

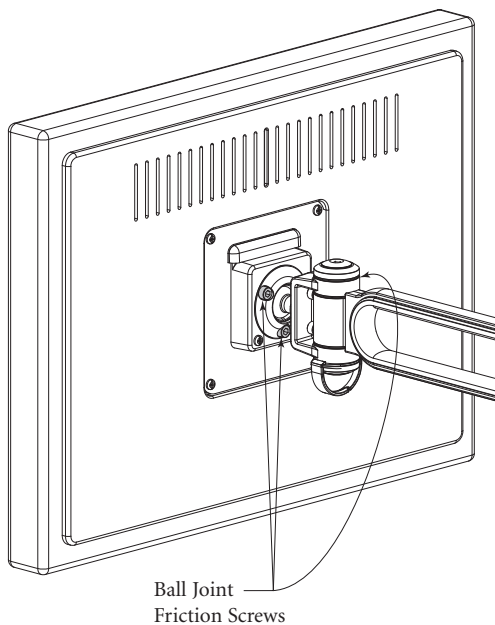
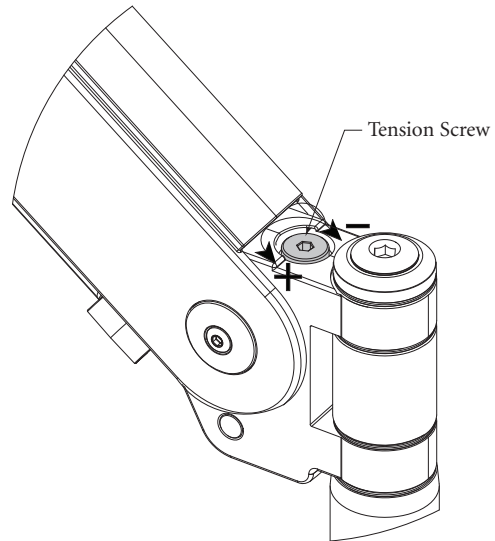

Figure L



Manual Adjustment Monitor Arm Attachment

Tools Required

- None

Clamp Mount Installation

Important: Holds a single monitor up to 20 lbs. For use only on the straight edge of a worksurface; not applicable for Knife, reverse Knife, and slope edges.

1. Remove Bottom Assembly from Base by loosening screws with hex key. (Figure A).
2. Position Base at surface edge. (Figure B).
Note: If Clamp is installed along wire manager edge of work surface, the bottom edge of the wire manager will need to be notched. (Figure C).
3. From under surface, reattach Bottom Assembly. Tighten screws and clamp Disk Screws with hex key to secure. (Figure D).
Note: Proceed to Step 11 Attach VESA Bracket to monitor.

Figure A

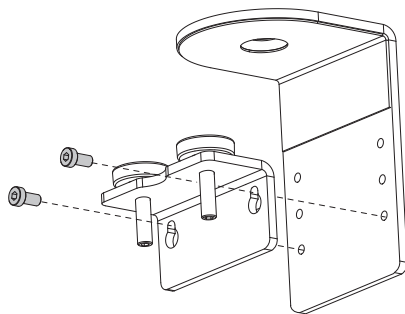

Figure B

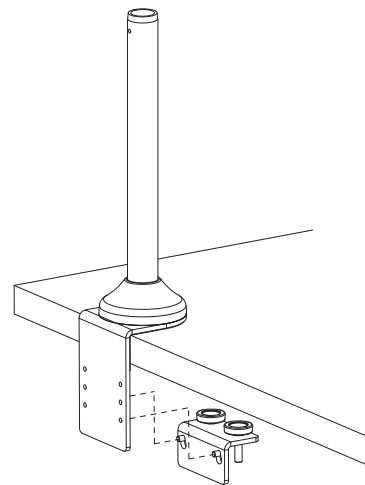

Figure C

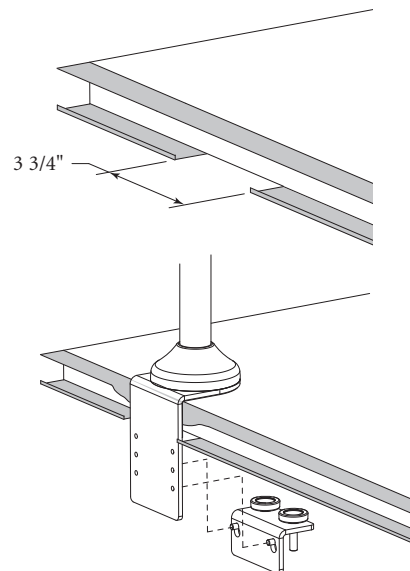
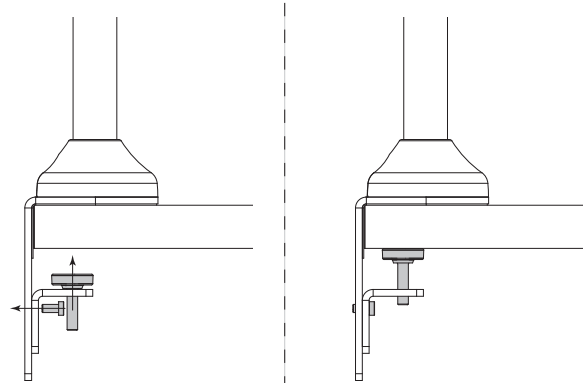

Figure D



Slat Mount Installation

Important: For use only on metal slat tiles, 24" and 30" with Cetra Slat Tiles, and 18", 24", or 30" with 1-high or 2-high Xsite Slat Tiles. 2-High Xsite slat tiles require an extra mid-frame support for stability, specified separately. One monitor arm per slat tile.

- Loosen set screws with hex key and slide bracket into grooves on slat wall. (Figure E).
- Tighten set screws with hex key until the brackets are securely fastened to the slat wall. (Figure E).

Note: Proceed to Step 11 Attach VESA Bracket to monitor.

Figure E

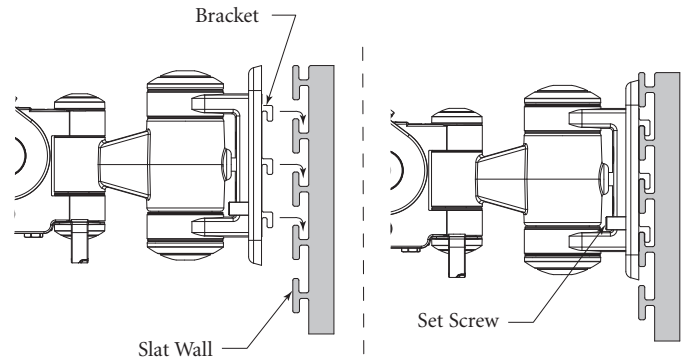

Bolt-Through Mount Installation

Important: Cannot be used with 1 9/16" worksurface or placed over a pedestal, modesty panel, or support panel.

- Drill 1/2" hole through surface in desired location.
- Apply protective foam sheet to bottom of base if desired.
- Pass large bolt through hole in curved plate. Make sure to note the direction of the curve. Pass bolt through hole in surface and screw into vertical assembly (pole). (Figure F).
- Verify that the small hole at the top of the pole is facing away from the user and then tighten large bolt with provided hex key.

Note: Proceed to Step 10 Attach Arm to Mounting Post and to Step 11 Attach VESA Bracket to monitor.

Figure F

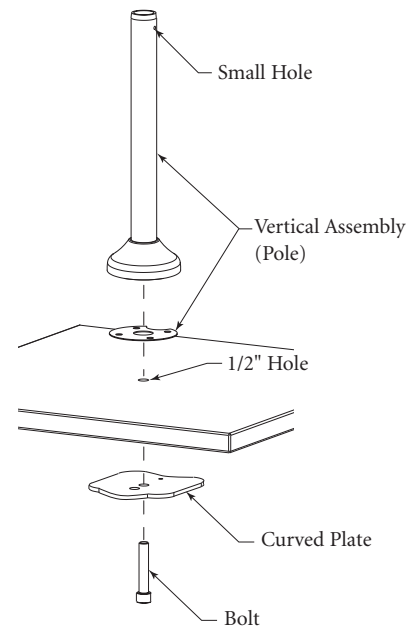

Arm to Mounting Post Installation

- Place bracket on Mounting Post. Tighten lever to secure at desired height. (Figure G).

Figure G

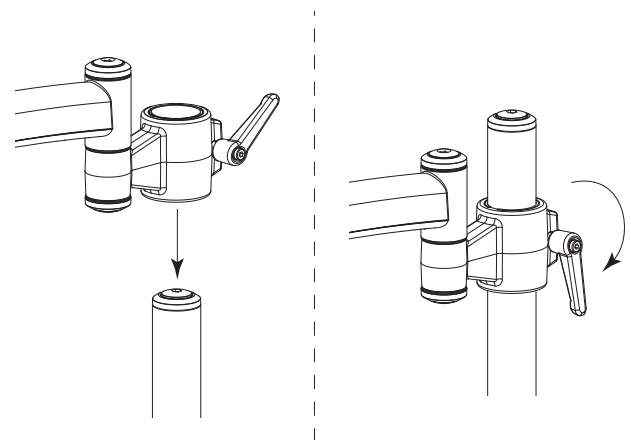

VESA Bracket to Monitor Installation

11. Select 75mm or 100mm VESA Bracket to match hole pattern on back of monitor.
12. Place VESA Bracket in position on back of monitor with cut-out toward top of monitor and attach using screws provided. For this you may also use screws that came with your monitor. (Figure H).

Important: Monitor should not exceed 20 lbs.

Monitor to Mounting Arm Installation

13. Place cut-out on VESA Bracket over Lip at end of Arm. Secure monitor to arm using two (2) screws. (Figure I).

Cable Management

14. Route the monitor and power cables through clip as shown. The clip for the pole must be opened and slipped over the pole and then secured with the supplied screw to the desired height as indicated. (Figure J).

Figure H

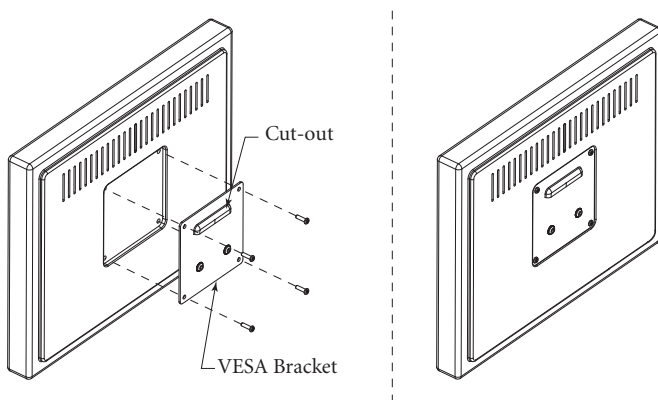

Figure I

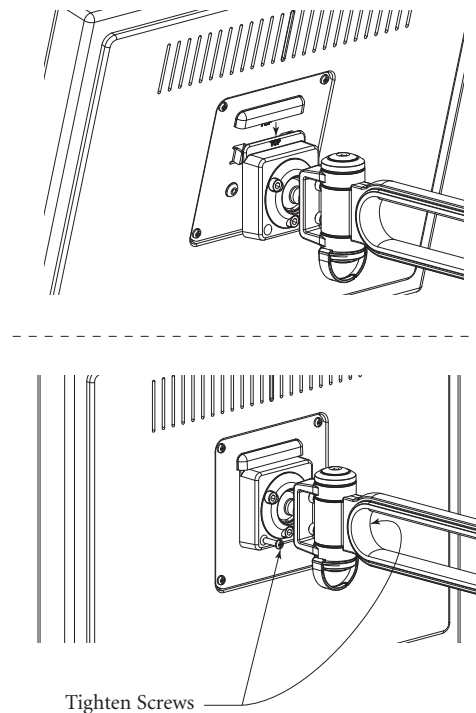
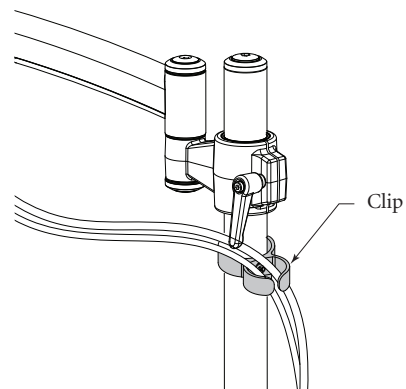

Figure J



Friction Adjustments

15. If desired, friction on the Ball Joint may be increased. This can be achieved by tightening the three (3) Ball Joint Friction Screws. (Figure K).

Figure K

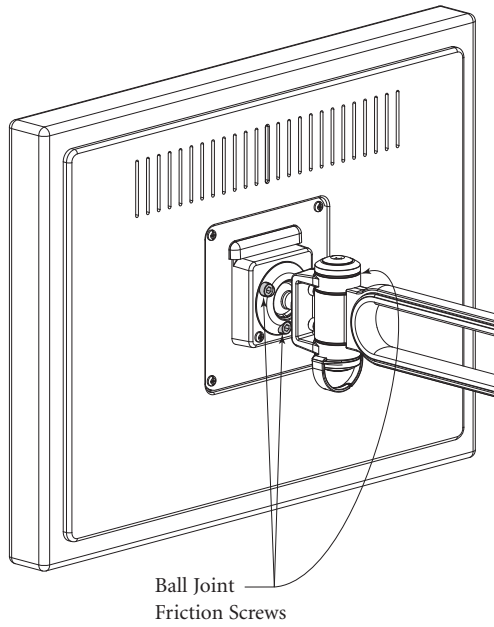

Name Plate Mounting

Tools Required

- None

Xsite Traxx, Traxx, and Slat Tile Mount

1. See Figure A.

Cetra & Interworks EQ - Panel Hook Mount

2. See Figure B.

Hard Surface Mount

3. Clean surface area which name plate will be mounted.
4. The flat mounting bracket is mounted with double faced tape. Remove protective strip from tape and place flat mounting bracket in desired location. (Figure C).
5. Place magnetic name holder on mounting bracket. (Figure C).

Glass Panel Mount

6. Clean surface area which name plate will be mounted.
7. The flat mounting bracket is mounted with double faced tape. Remove protective strip from tape and place flat mounting bracket in desired location. On the reverse side of glass, remove paper backer from blinder and position it to hide the mounting bracket on the opposite side of the glass. (Figure D).
8. Place magnetic name holder on mounting bracket. (Figure D).

Figure A

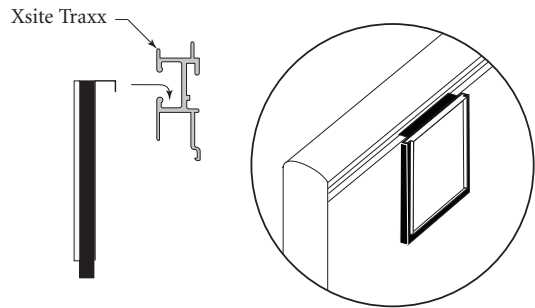

Figure B

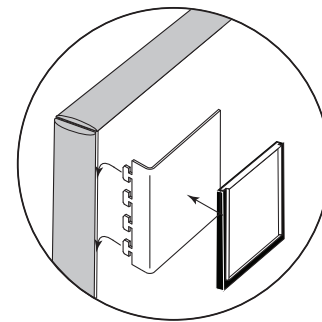

Figure C

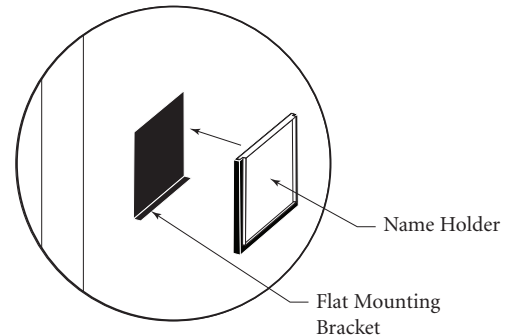
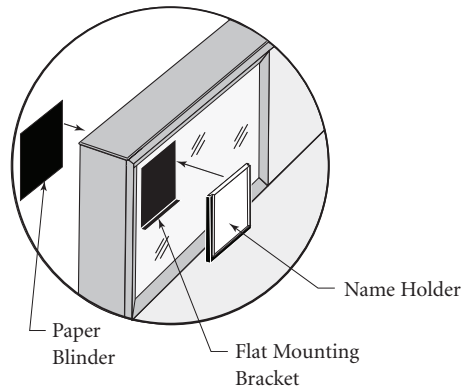

Figure D



Printed in U.S.A. © 2008 Kimball International, Inc. T 800.482.1818 F 812.482.8300

Voice/Data and Power Modules

Tools Required

- None

Package Contents

- 1 Voice/Data Module or Power Module

Installation

1. For installation in wire manager, feed all cabling from the module through the wire management channel. Position the lower flange of the module into the rubber portion of the channel. (Figure A).

Figure A

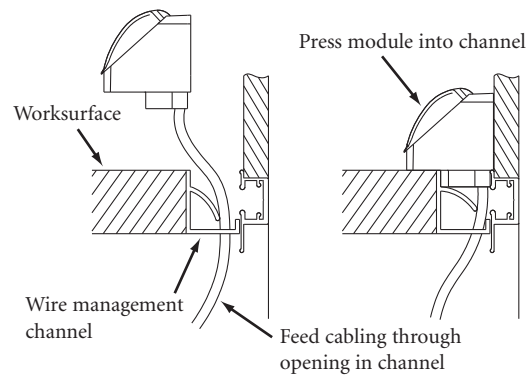

Undersurface Cable Manager

Tools Required

- #2 Phillips Head Bit
- Screw Gun
- Hack Saw
- (if cutting to length)

Package Contents

- 12 #8 Panhead Screws

Installation

1. Measure the area where the Undersurface Cable Manager is to be mounted. Mark and cut the cable manager to the desired length.
2. On “W” shaped cable manager, peel the protective coating from the tape strip provided. Position the cable manager in its desired location and press firmly into place. “U” shaped cable managers does not come with tape strip. (Figure A).
3. The cable managers can be permanently attached to the underside of the worksurface using #8 panhead screws provided. The “W” shape has a V-groove to assist with screw location. (Figure B).

Figure A

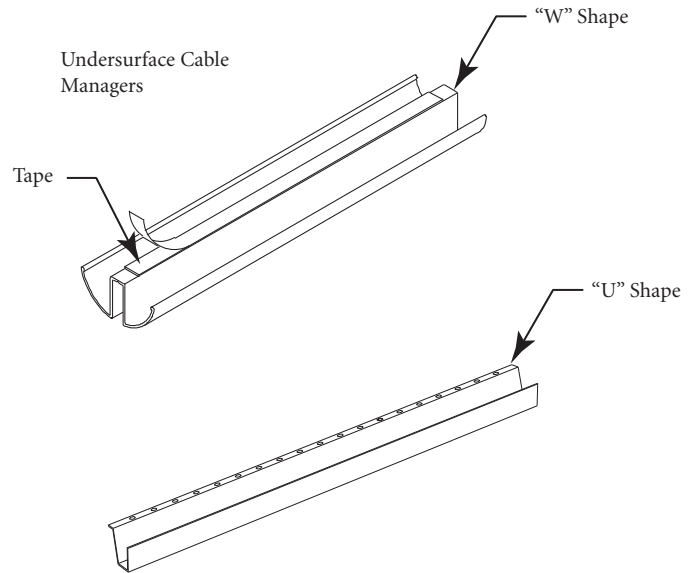
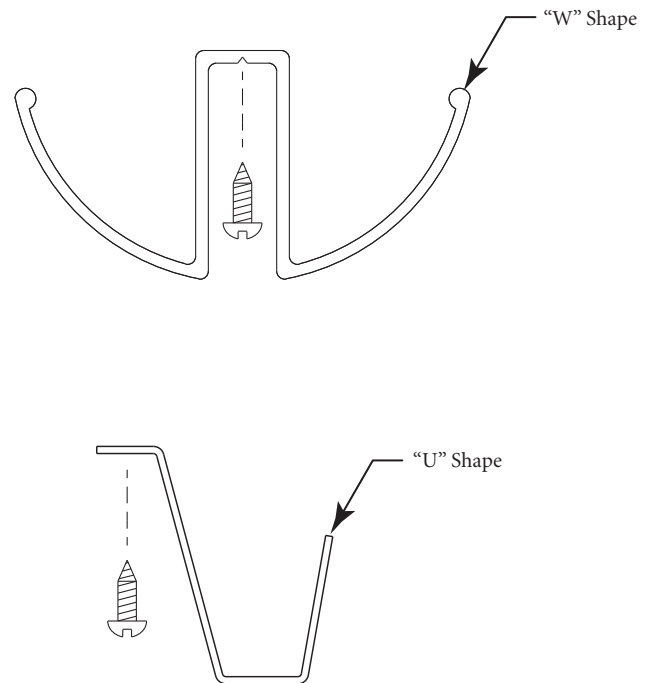

Figure B



Printed in U.S.A. © 2008 Kimball International, Inc. T 800.482.1818 F 812.482.8300

Vertical Cable Manager

Tools Required

- None

Package Contents

- None

Installation

1. See Figure A & Figure B.

Figure A

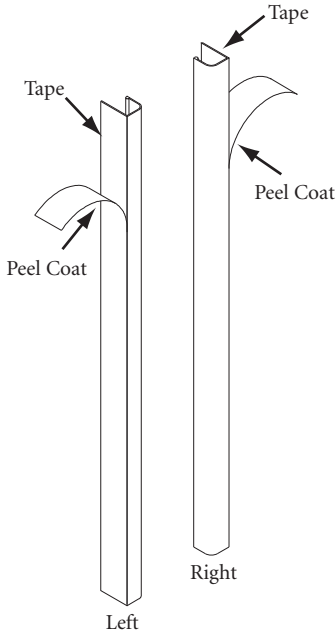
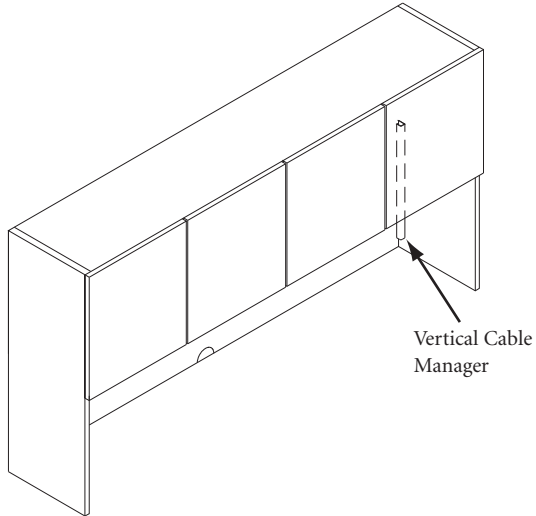

Figure B



Printed in U.S.A. © 2008 Kimball International, Inc. T 800.482.1818 F 812.482.8300

Proper product installation, in accordance with these instructions, is the responsibility of the installing agent. If you have any questions concerning these instructions, please call Kimball Office Customer Service.

Kimball Office

Undersurface Power/Data Center

Tools Required

- Screwdriver

Package Contents

- 1 Electrical Module
- 1 Mounting Frame
- 2 Screws

Installation

1. Select mounting location for the power/data center frame.
It is suggested that the power/data center be mounted where it is easily visible and accessible. (Figure A).
Note: If the frame is being mounted to an Aspire folding table, make sure it does not span any folds. Also, be sure it does not interfere with any cables or springs and that it does not block access to any locking mechanisms.
2. Mount frame to underside of worksurface using the two screws provided. (Figure B).
3. Pass the plug end through the frame. (Figure C). Firmly push the power/data center into frame until it snaps into place. (Figure D).
Note: If desired, electrical module can be mounted in the frame in the inverted position.

Figure A

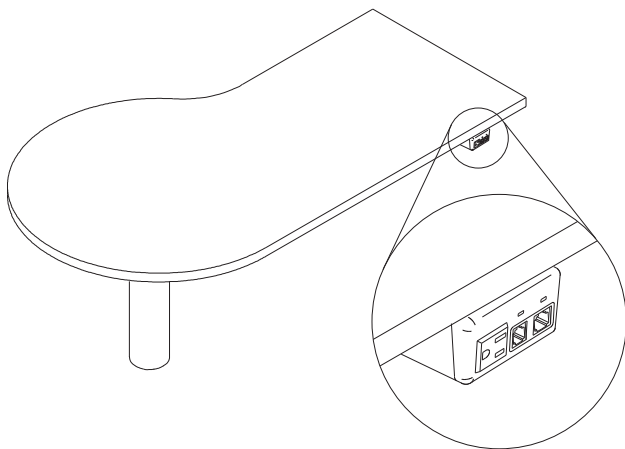

Figure B

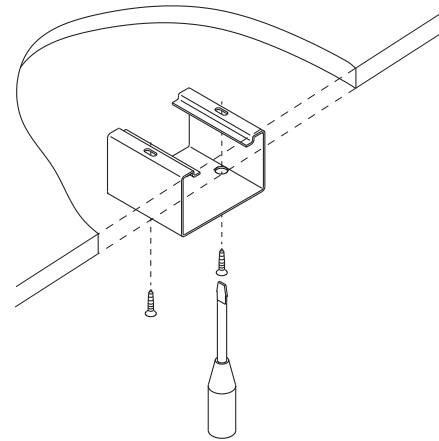

Figure C

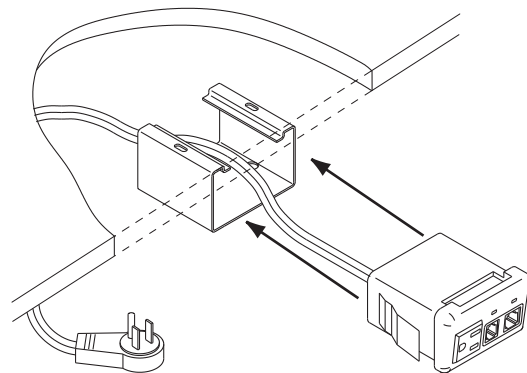
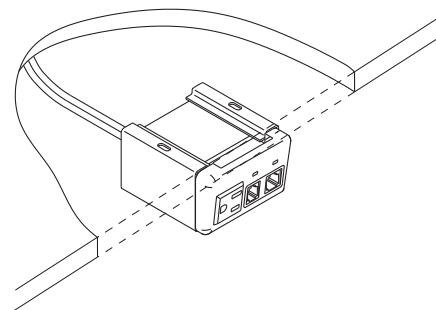

Figure D



Power/Data Grommet Insert

Tools Required

- None

Package Contents

- 1 Power/Data Grommet Insert

General Information

- The power/data grommet insert can be located in any worksurface. It is used when it is desirable to have access to electrical power and telephone/data at the worksurface. Excess cabling can be routed under the worksurface through an opening in the metal cap.
- Check for clearance under worksurface **BEFORE** boring to avoid brackets, panels or similar interferences.
- Fits G7 grommet/option on Evoke, Definition, Transcend, Senator, President, Innsbruck, and Osterley Park.

Installation

1. If worksurface has existing grommet, remove the plastic trim ring that came with the metal grommet cap, and replace it with the power/data grommet insert cup. (Figure A).
Note: If worksurface does not contain grommet, refer to Grommet Installation assembly instructions.
2. A universal knock-out is a feature of the power/data connector cup. The knock-out will work with the following data ports:
 - Amp - 1.800.522.6752
 - Panduit - 1.800.777.3300 ex. 1884
 (Figure B).

Figure A

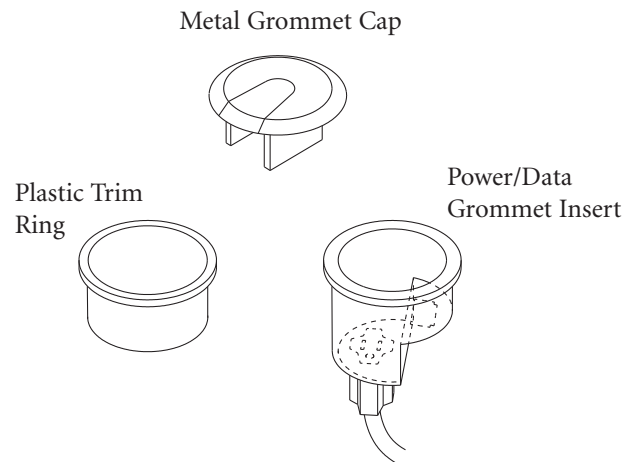
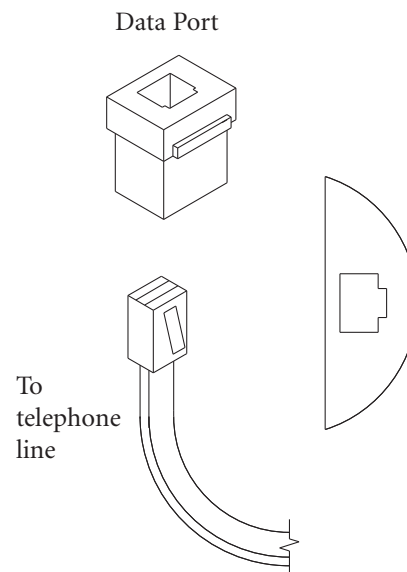

Figure B



Field Installed Grommet

Tools Required

- Tape Measure
- Rubber Mallet
- Hole Saw
- Power Drill
- Drill Bit - As Required

Package Contents

- Grommet (qty. per order)

General Information

- Grommets can be located in any worksurface.
- Check for clearance under worksurface **BEFORE** boring to avoid brackets, panels or similar interferences.

Installation

1. Verify the model number for the grommet being installed and note appropriate drill bit to be used. (Figure A).
2. Prepare face side of surface (drilling side) by placing masking tape or similar material over area to be drilled to prevent tear out. Measure and mark grommet location noting minimum distances recommended from the edge of the core material or adjacent worksurface. Using specified drill bit, bore hole through worksurface as shown. (Figure B).
3. Place grommet in hole. As required, use rubber mallet to secure grommet into place by tapping grommet along its outer edges, not in the center. Install grommet cap.

Figure A

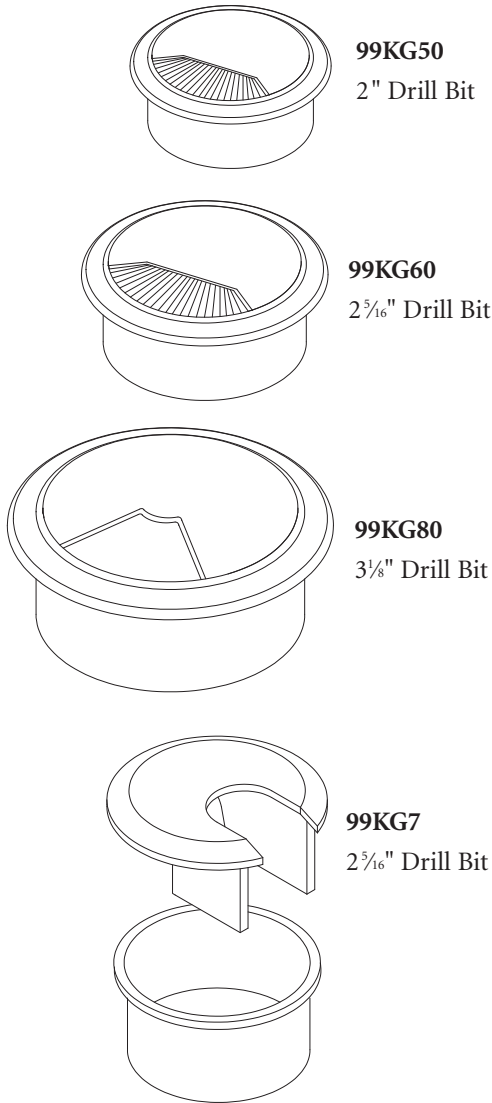
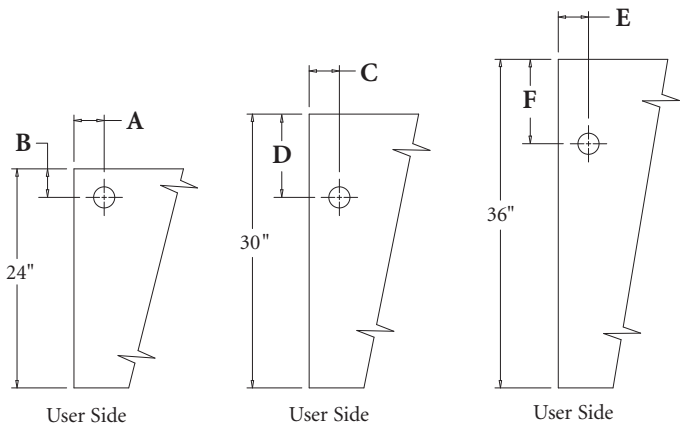

Figure B

Series	Dimensions					
	A	B	C	D	E	F
Definition	3 3/8"	3 3/8"	3 3/8"	9 3/8"	3 3/8"	9 3/8"
Invoke	14 1/8"	5 3/8"	14 1/8"	5 3/8"	14 1/8"	5 3/8"
Prevail	3 5/16"	3 5/16"	3 5/16"	7 23/32"	3 5/16"	9 1/16"
Priority	3 3/8"	3 3/8"	3 3/8"	7 1/2"	3 3/8"	7 1/2"
Transcend	5"	5"	5"	7 1/4"	5"	7 1/4"
Footprint	5"	5"	5"	5"	5"	5"



Proper product installation, in accordance with these instructions, is the responsibility of the installing agent. If you have any questions concerning these instructions, please call Kimball Office Customer Service.

Kimball®Office

Panel Mount Markerboard or Tackboard

Tools Required

- Tape Measure
- Level
- Phillips Screwdriver
- Drill

Package Contents

- 1 Markerboard or Tackboard
- 1 Pencil Tray (Markerboard only)
- 2 Cabinet Spacers
- 8 #8 x 5/8" Panhead Phillips Sheet Metal Screws
- 2 End Panel Brackets
- 5 #10 x 1" Truss Head Phillips Sheet Metal Screws (Markerboard only)
- 4 1/2" Screws for Marker Tray

Installation

1. Attach pencil tray to front of board using four 1/2" screws provided. (Figure A).
2. Attach end panel brackets to top rear side of board, and attach cabinet spacers to bottom rear side of board using 5/8" sheet metal screws provided as shown. Make sure hooks on end panel brackets are pointing down. (Figure B).
3. Hold the board securely in front of desired location in panel run. (Figure C). Tilt top of board slightly toward panel and insert top hooks of both end panel brackets into openings in "J" members between panels. Rotate board to enable bottom hooks of end panel brackets to engage "J" members. Press down firmly to lock into position. (Figure D).

Figure A

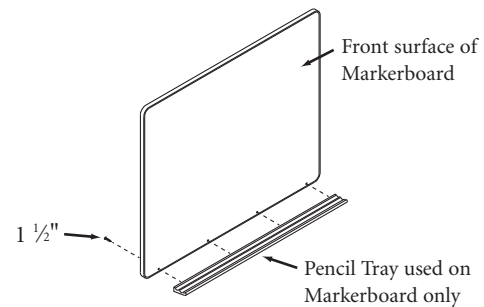

Figure B

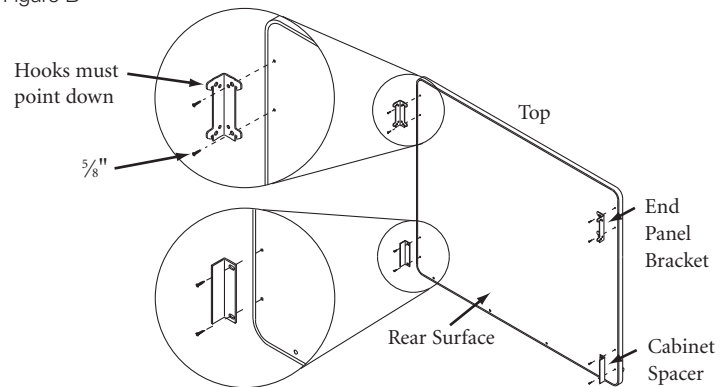

Figure C

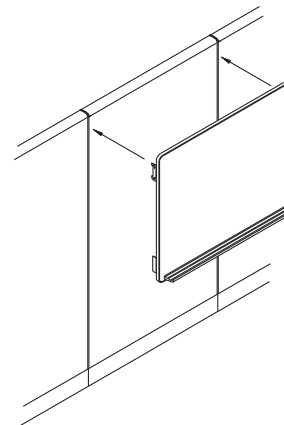
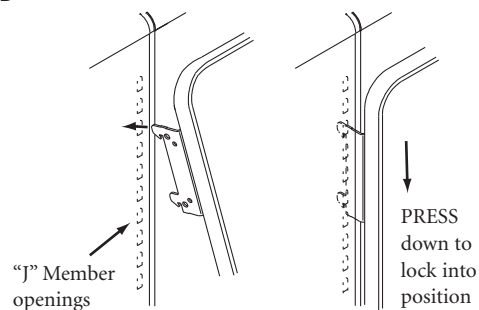

Figure D



Corner Sleeve

Tools Required

- Screw Gun
- #2 Phillips Head Bit

Hardware Required (Included)

- 2 #8 x 5/8" Panhead Screws

Installation

1. See Figure A.

Figure A

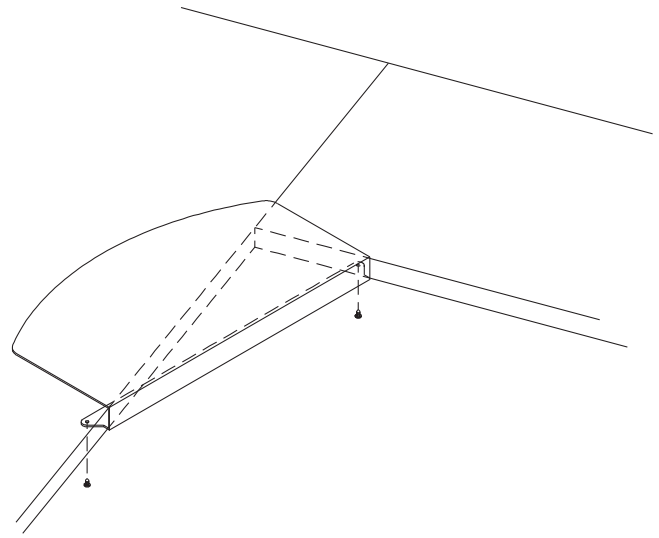

Optional Keyboard Kit to Corner Sleeve Attachment

Hardware Required (Included)

- 2 #8-32 x 1/2" Long Machine Screws
- 2 #8-32 K Locknuts

Installation

1. See Figure B.

Figure B

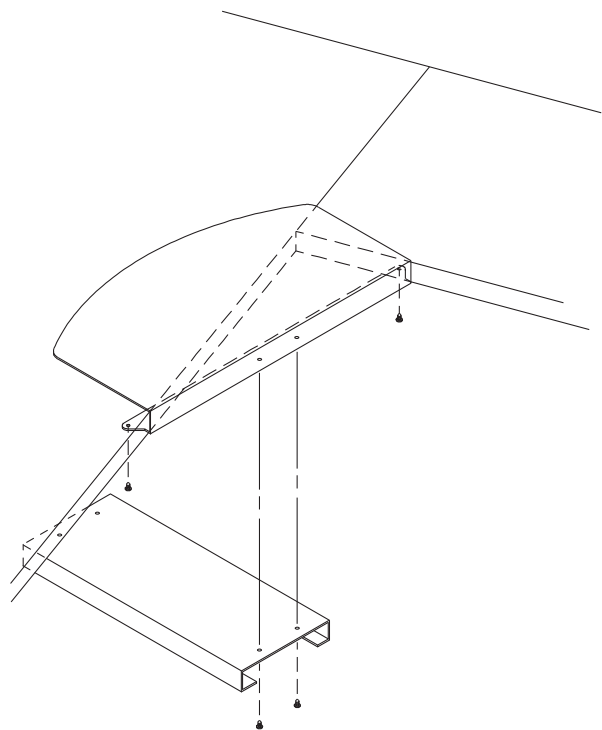

Printed in U.S.A. © 2008 Kimball International, Inc. Kimball Office T 800.482.1818 F 812.482.8300
 National T 800.482.1717 F 812.482.8800

Proper product installation, in accordance with these instructions, is the responsibility of the installing agent. If you have any questions concerning these instructions, please call Kimball Office Customer Service.

Equipment Lock

Tools Required

- 1/16" Drill Bit

Installation

1. The Equipment Lock consists of two locks tethered together by a stainless steel cable. The rear of each lock has a T-shaped prong which engages into the Kensington slot that is located in laptop computers, docking stations, printers, CPU towers and other portable electronic equipment. The two locks are equipped with removable lock cores which can be re-keyed to suit user-preference. (Figure A).

Figure A

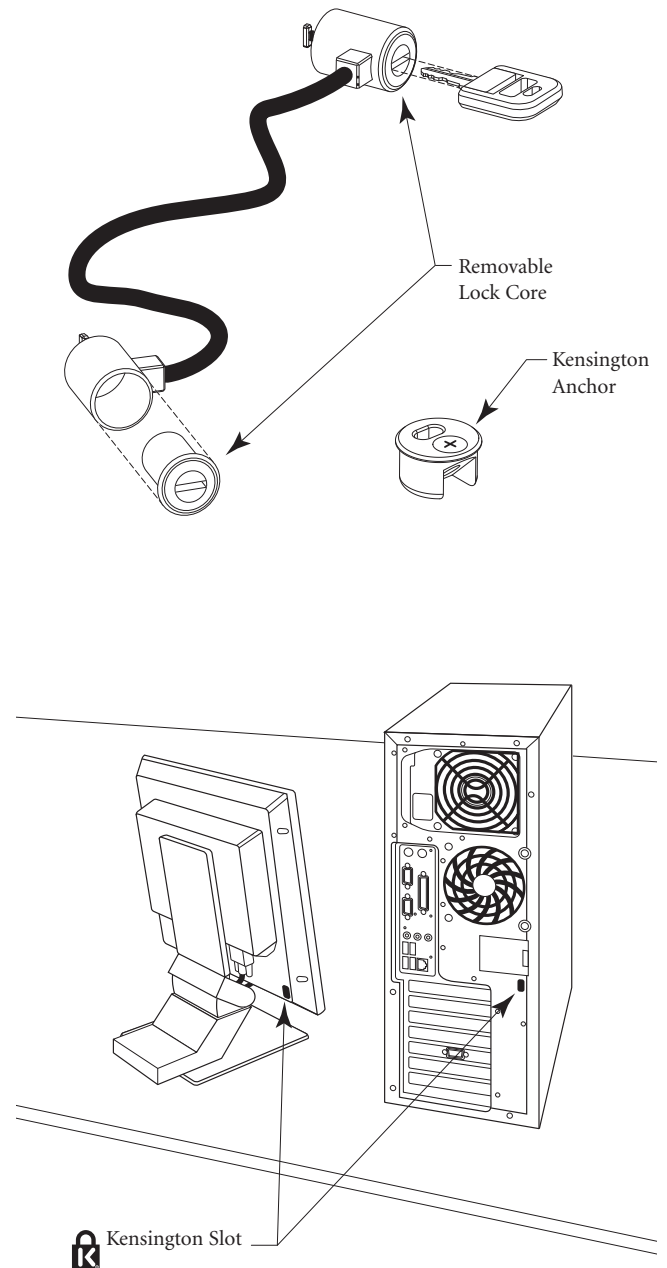

Installation (continued)

Scenario

- The Senario Tables have a Kensington slot machined into each undersurface support arm. One end of the security cable secures to the slot in the furniture, the other can be secured into the Kensington slot in the portable equipment. (Figure B).
- The round Scenario tables have a Kensington slot located in the mounting plate on the underside of the worksurface. (Figure C).

Hum

- The Hum cable managers have Kensington slots stamped into the lower floor of the tray. One end of the security cable secures to the slot in the cable manager, the other end can be secured into the Kensington slot in the portable equipment. (Figure D).

Kensington Wood Anchor

- The Kensington Wood Anchor can be field-installed into any wood-based panel. Bore an $\frac{1}{16} \times \frac{1}{2}$ " deep hole into the furniture, push the Kensington Wood Anchor into the hole, and tighten the screw to secure the anchor to the furniture. We recommend the underside of a worksurface (near a grommet hole) or the inside of an end panel as potential hole location. (Figure E).

Figure B

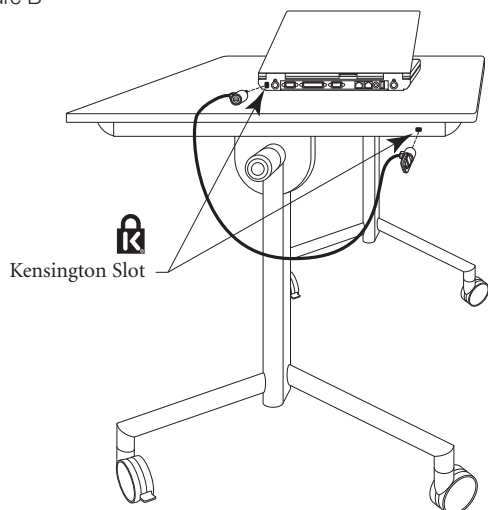

Figure C

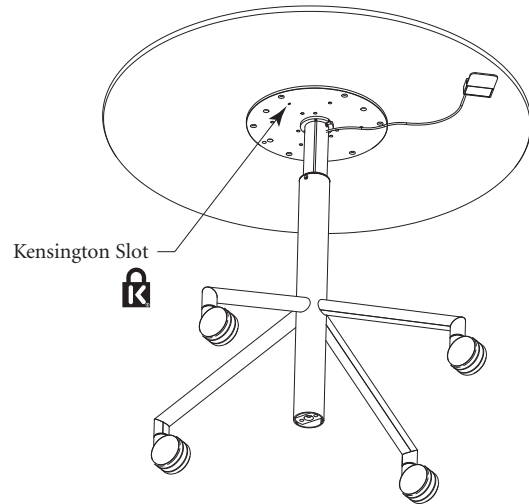

Figure D

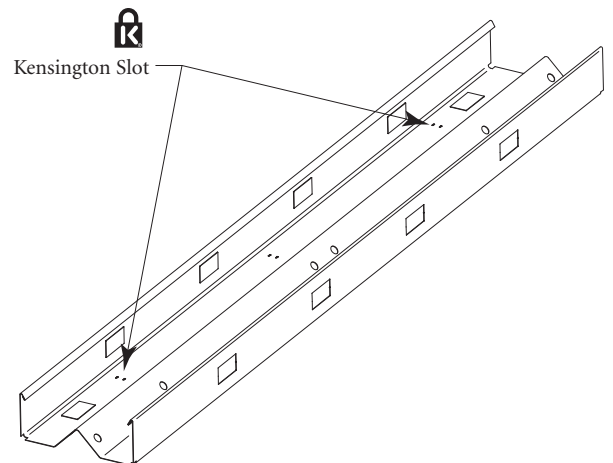

Figure E

