

# Name Plate Mounting

## Tools Required

- None

## Xsite Traxx, Traxx, and Slat Tile Mount

1. See Figure A.

## Cetra & Interworks EQ - Panel Hook Mount

2. See Figure B.

## Hard Surface Mount

3. Clean surface area which name plate will be mounted.
4. The flat mounting bracket is mounted with double faced tape. Remove protective strip from tape and place flat mounting bracket in desired location. (Figure C).
5. Place magnetic name holder on mounting bracket. (Figure C).

## Glass Panel Mount

6. Clean surface area which name plate will be mounted.
7. The flat mounting bracket is mounted with double faced tape. Remove protective strip from tape and place flat mounting bracket in desired location. On the reverse side of glass, remove paper backer from blinder and position it to hide the mounting bracket on the opposite side of the glass. (Figure D).
8. Place magnetic name holder on mounting bracket. (Figure D).

Figure A

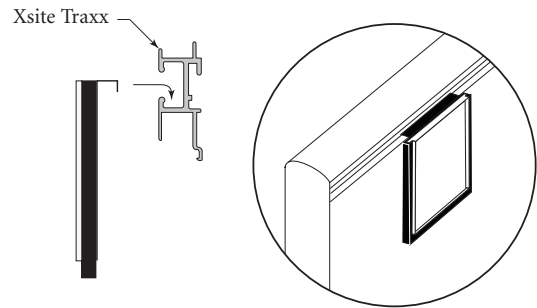

Figure B

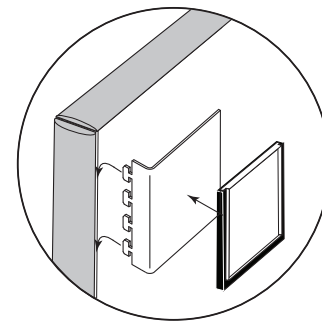

Figure C

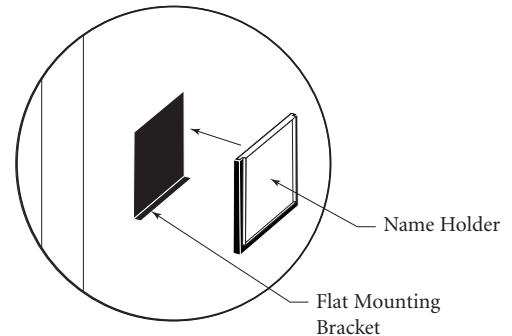
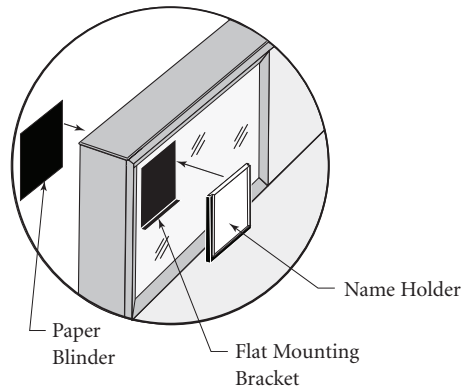

Figure D



Printed in U.S.A. © 2008 Kimball International, Inc. T 800.482.1818 F 812.482.8300