

Manual Adjustment Monitor Arm Attachment

Tools Required

- None

Clamp Mount Installation

Important: Holds a single monitor up to 20 lbs. For use only on the straight edge of a worksurface; not applicable for Knife, reverse Knife, and slope edges.

1. Remove Bottom Assembly from Base by loosening screws with hex key. (Figure A).
2. Position Base at surface edge. (Figure B).

Note: If Clamp is installed along wire manager edge of work surface, the bottom edge of the wire manager will need to be notched. (Figure C).

3. From under surface, reattach Bottom Assembly. Tighten screws and clamp Disk Screws with hex key to secure. (Figure D).

Note: Proceed to Step 11 Attach VESA Bracket to monitor.

Figure A

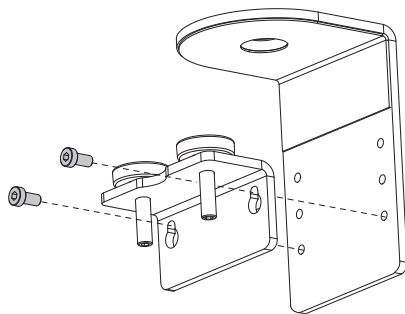

Figure B

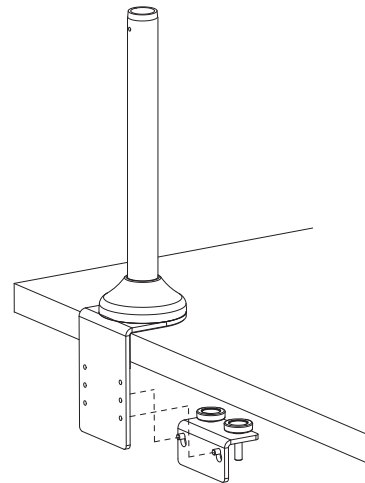

Figure C

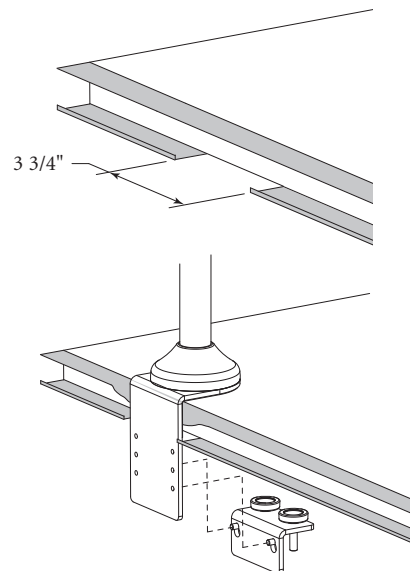
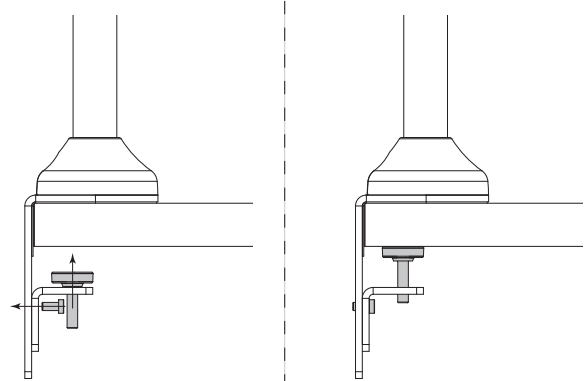

Figure D



Slat Mount Installation

Important: For use only on metal slat tiles, 24" and 30" with Cetra Slat Tiles, and 18", 24", or 30" with 1-high or 2-high Xsite Slat Tiles. 2-High Xsite slat tiles require an extra mid-frame support for stability, specified separately. One monitor arm per slat tile.

- Loosen set screws with hex key and slide bracket into grooves on slat wall. (Figure E).
- Tighten set screws with hex key until the brackets are securely fastened to the slat wall. (Figure E).

Note: Proceed to Step 11 Attach VESA Bracket to monitor.

Figure E

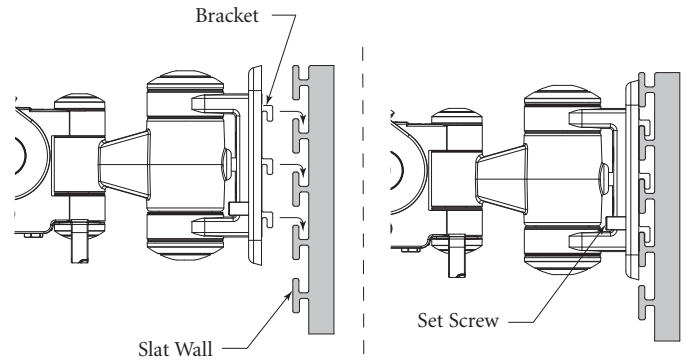

Bolt-Through Mount Installation

Important: Cannot be used with 1 9/16" worksurface or placed over a pedestal, modesty panel, or support panel.

- Drill 1/2" hole through surface in desired location.
- Apply protective foam sheet to bottom of base if desired.
- Pass large bolt through hole in curved plate. Make sure to note the direction of the curve. Pass bolt through hole in surface and screw into vertical assembly (pole). (Figure F).
- Verify that the small hole at the top of the pole is facing away from the user and then tighten large bolt with provided hex key.

Note: Proceed to Step 10 Attach Arm to Mounting Post and to Step 11 Attach VESA Bracket to monitor.

Figure F

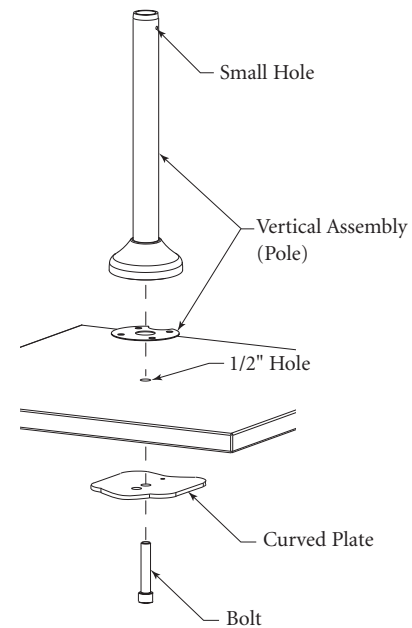

Arm to Mounting Post Installation

- Place bracket on Mounting Post. Tighten lever to secure at desired height. (Figure G).

Figure G

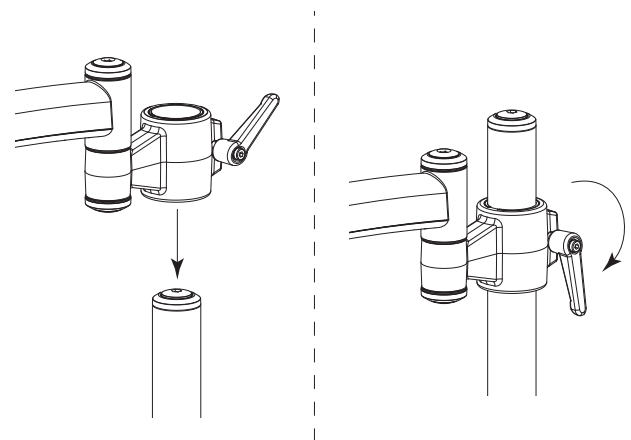

VESA Bracket to Monitor Installation

11. Select 75mm or 100mm VESA Bracket to match hole pattern on back of monitor.
12. Place VESA Bracket in position on back of monitor with cut-out toward top of monitor and attach using screws provided. For this you may also use screws that came with your monitor. (Figure H).

Important: Monitor should not exceed 20 lbs.

Monitor to Mounting Arm Installation

13. Place cut-out on VESA Bracket over Lip at end of Arm. Secure monitor to arm using two (2) screws. (Figure I).

Cable Management

14. Route the monitor and power cables through clip as shown. The clip for the pole must be opened and slipped over the pole and then secured with the supplied screw to the desired height as indicated. (Figure J).

Figure H

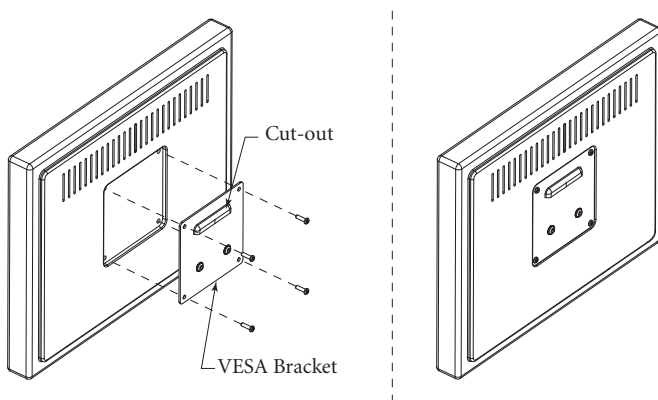

Figure I

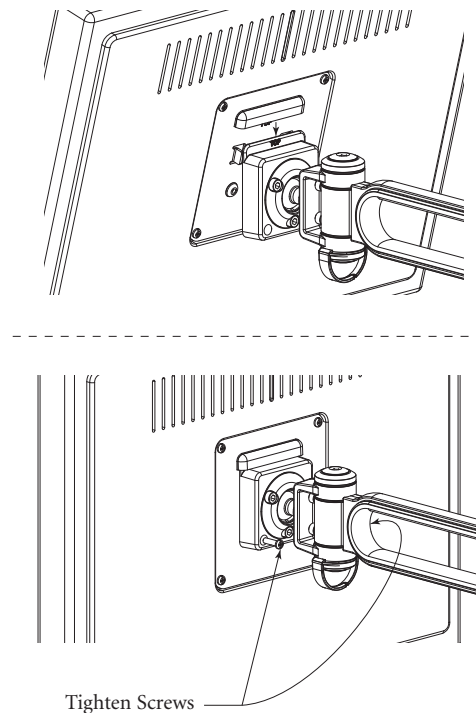
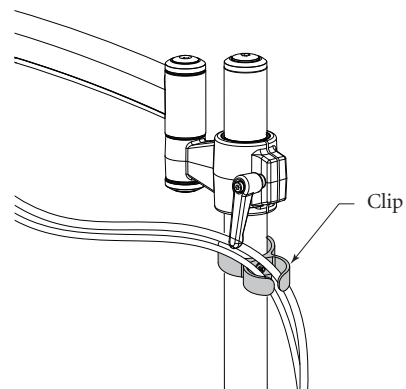

Figure J



Friction Adjustments

15. If desired, friction on the Ball Joint may be increased. This can be achieved by tightening the three (3) Ball Joint Friction Screws. (Figure K).

Figure K

