

## Corner Sleeve

### Tools Required

- Screw Gun
- #2 Phillips Head Bit

### Hardware Required (Included)

- 2 #8 x 5/8" Panhead Screws

### Installation

1. See Figure A.

Figure A

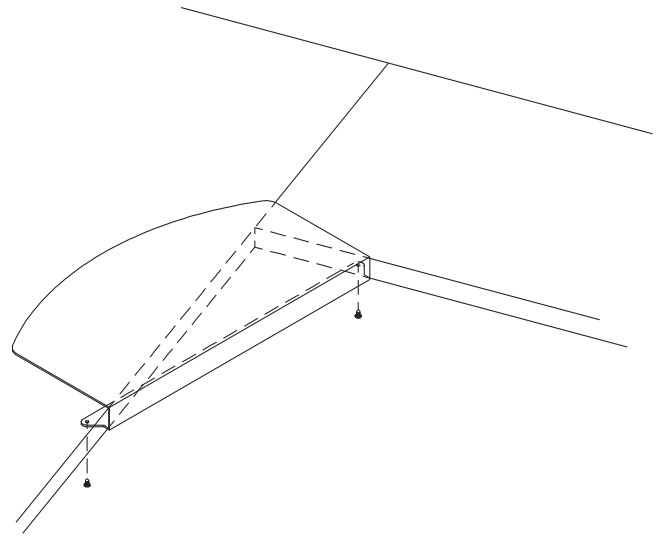

## Optional Keyboard Kit to Corner Sleeve Attachment

### Hardware Required (Included)

- 2 #8-32 x 1/2" Long Machine Screws
- 2 #8-32 K Locknuts

### Installation

1. See Figure B.

Figure B

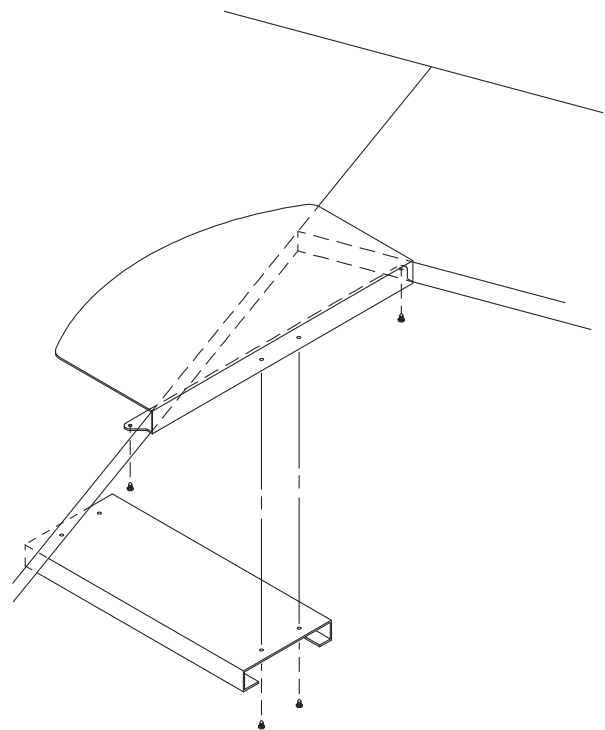

Printed in U.S.A. © 2008 Kimball International, Inc. Kimball Office T 800.482.1818 F 812.482.8300  
 National T 800.482.1717 F 812.482.8800

Proper product installation, in accordance with these instructions, is the responsibility of the installing agent. If you have any questions concerning these instructions, please call Kimball Office Customer Service.