

Prevail™

Modesty Panel for U-Shaped Desk

Tools Required

- Tape Measure
- #2 Phillips Head Bit
- Power Screwdriver

Package Contents

- 1 Modesty Panel
- 10 #8 x 1¼" Cleat
- 10 #8 x 1¼" Panhead Screws

Installation

Note: It is recommended that more than one person be used to install the Modesty Panel and/or move the U-Shaped desk.

- Determine the user side of the U-shaped desk. The side of the desk with the inset door on the end support panel is considered the user side. (Figure A).
- The Modesty Panel has two (2) mounting cleats that are pre-attached. All mounting cleats will face the user side of the desk. Place the Modesty Panel face down (cleats up) on a smooth solid surface. Determine which end of the Modesty Panel will be flush to the desk end support panel. Center the 10" cleat on that end of the Modesty panel, making sure one side of the cleat and end of the Modesty Panel are flush. Attach the 10" cleat to the Modesty Panel with two (2) of the #8 x 1¼" Panhead screws provided. (Figure B).

Note: If U-Shaped Desk is already attached to a return or U-configuration, skip to Step 4.

- Carefully turn the U-Shaped Desk upside down on a smooth, solid surface. Take care to not mar the worksurface.
- Position the Modesty Panel on the underside of the worksurface, centered on the support panel and the metal desk leg. Make sure all cleats face the user side and the 10" cleat is flush against the end support panel. (Figure C).

Figure A

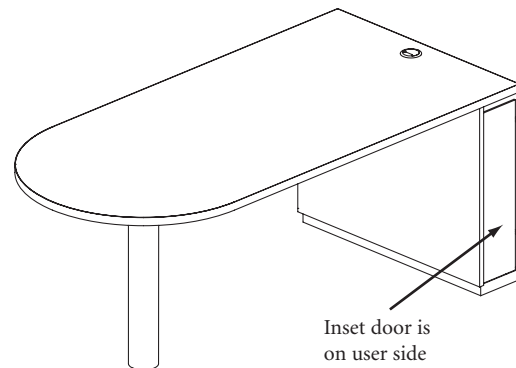

Figure B

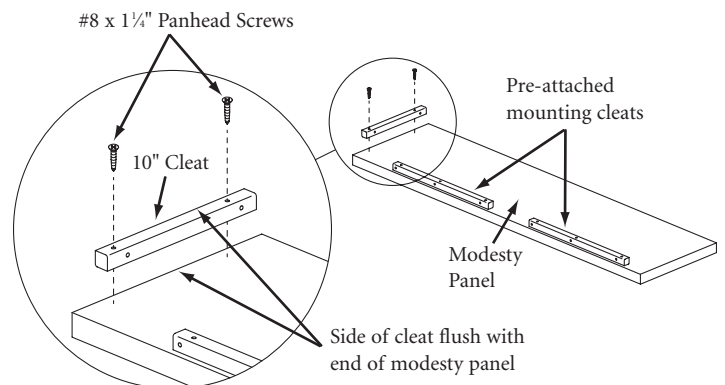
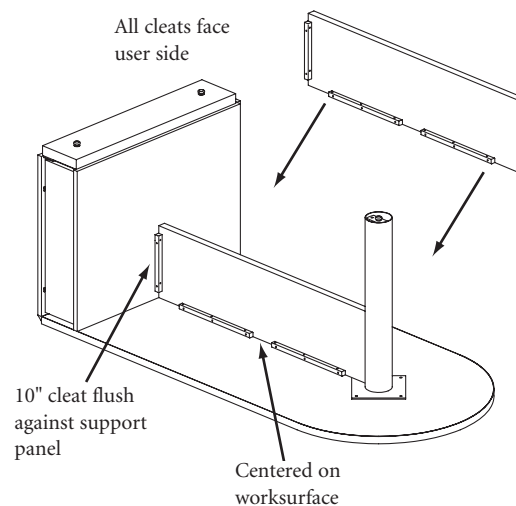

Figure C



Prevail

Installation (continued)

5. Attach each of the longer cleats to the underside of the worksurface with three (3) of the #8 x 1/4" Panhead screws provided, inserted through the pre-drilled holes.

Caution: Over-driving the screws could cause them to break through the worksurface.

Attach the 10" cleat to the end support panel with two (2) of the #8 x 1/4" Panhead screws provided, inserted through the pre-drilled holes. (Figure D).

6. If assembled unit is upside down, carefully turn upright. The illustration shows the U-Shaped desk from the approach side. (Figure E).

Figure D

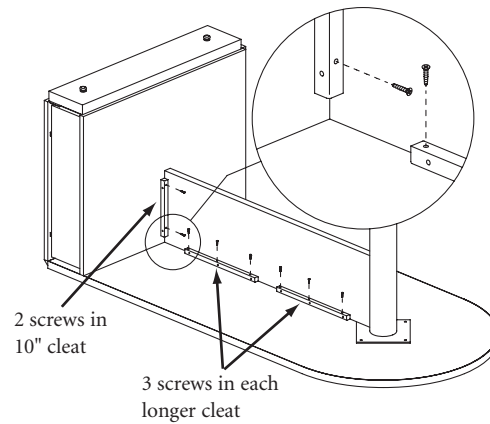

Figure E

