

Prevail®

Modesty Panel Attachment to Credenza

Tools Required

- Phillips Screwdriver
- Phillips Head Bit
- or Screw Gun

Package Contents

- Credenza
- Modesty Panel
- Hinges (2 or 3)
- 2 Slide Bolts
- 4 #6 x 3/4" Screws
- #8 x 1" Screws (6 for 2 hinges, 9 for 3 hinges)
- #8 x 5/8" Screws (6 for 2 hinges, 9 for 3 hinges)

Installation

1. Mount each hinge to the bottom of the unit worksurface using three (3) #8 x 1" screws inserted into the pre-drilled holes in the worksurface. (Figure A).

Note: Longer unit lengths use three (3) hinges.

2. Attach Modesty Panel to hinges by inserting six (6) or nine (9) #8 x 5/8" screws provided through hinges and into pre-drilled holes in the back of the Modesty Panel. (Figure B).

Note: At this point, secure Modesty Panel tight enough to hold in place. Once assembled unit is mounted between other units and leveled, utilize the slotted mounting holes for final adjustment and alignment.

3. Install the slide bolts into the modesty panel using the #6 x 3/4" screws provided. Take care that the bolts slide in the proper direction. (Figure C).
4. Each slide bolt will have a corresponding slot to accept it. (Figure D).

Figure A

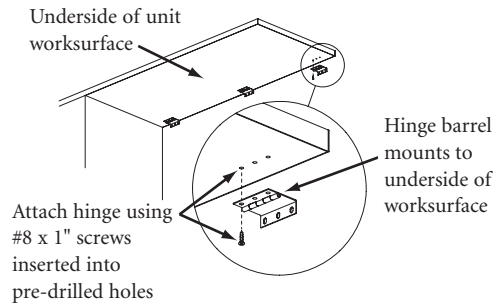

Figure B

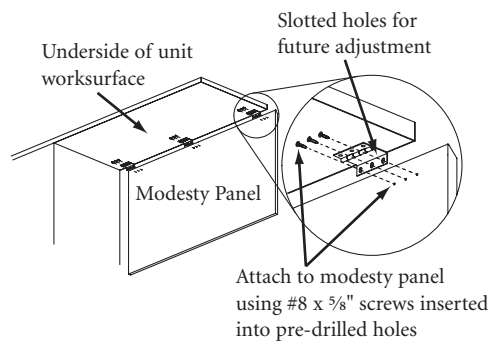

Figure C

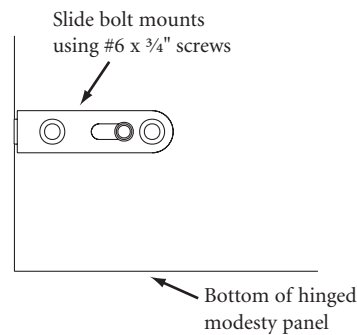

Figure D

