

Prevail™

“U” Shaped Desk

Tools Required

- Level
- #2 Phillips Head Bit
- 7/32" Nut Driver
- Tape Measure
- Screw Gun

Package Contents

- Beveled Door

Installation

Note: The “U” Shaped Desk is not intended to be used as a stand-alone unit. It should always be used in conjunction with a return.

1. Place unit in desired location. Level unit. Leveling glides can be accessed by opening doors of the “U” shaped desk and the bottom of the column leg. (Figure A).
2. The “U” shaped desk design allows for attachment of either right- or left-hand returns and bridges. This instruction will show a sample installation of a RIGHT HAND return.
3. Please be aware! For shipping purposes, the beveled door is shipped in a separate box within the main carton. It is attached to the corrugated support tube around the column leg. It is attached to the corrugated support tube around the column leg.
4. The beveled door panel will always be on the APPROACH side of the desk. (Figure B). The doors should be switched to the proper sides to accommodate both right and left hand applications. The “U” shaped desk comes with additional, pre-installed hinge plates to accommodate the switching of doors. (Figure C).

Figure A

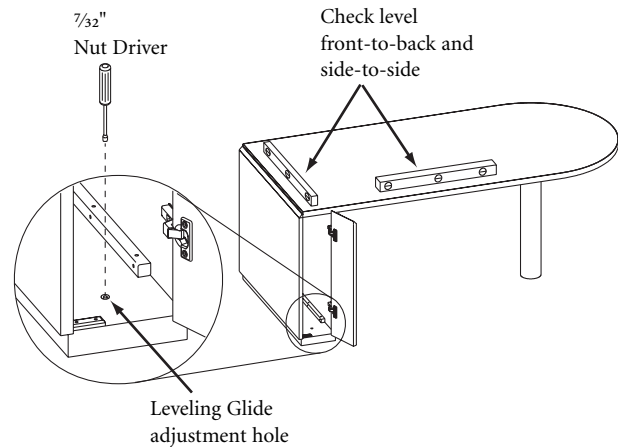

Figure B

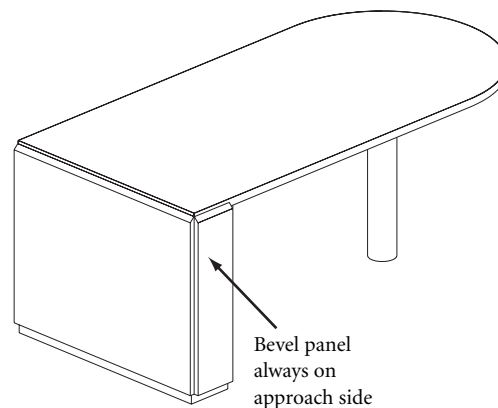
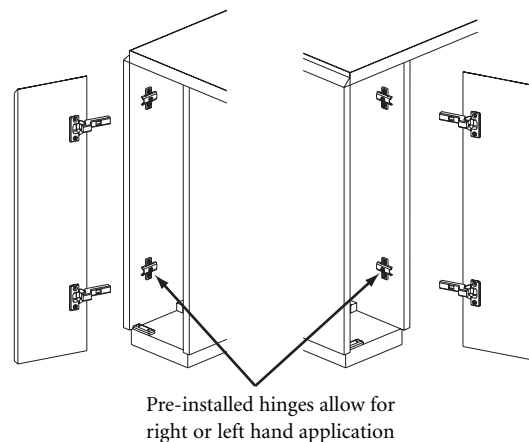

Figure C



Prevail

Installation (continued)

5. For DOOR REMOVAL AND INSTALLATION: For removal, firmly pull hinge release lever back. To re-install, place the hinge on the mounting plate and push the rear of the hinge with finger pressure. The “snap” sound confirms a secure attachment. (Figure D).
6. For SIDE ADJUSTMENT OF DOOR: Turn hinge front screw clockwise to increase door overlay; counterclockwise to decrease overlay. (Figure E).
7. For DOOR DEPTH ADJUSTMENT: Loosen hinge rear screw. Adjust door to desired position and re-tighten rear screw. (Figure F).

Figure D

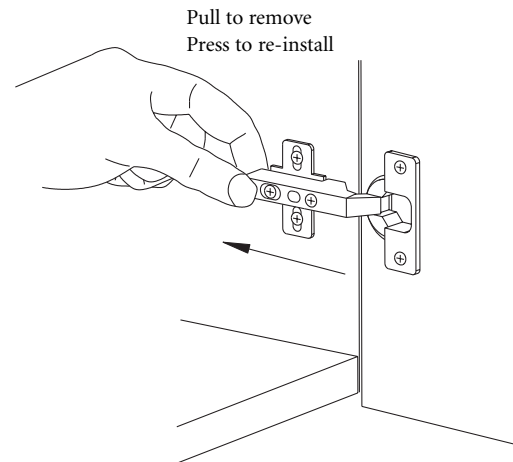

Figure E

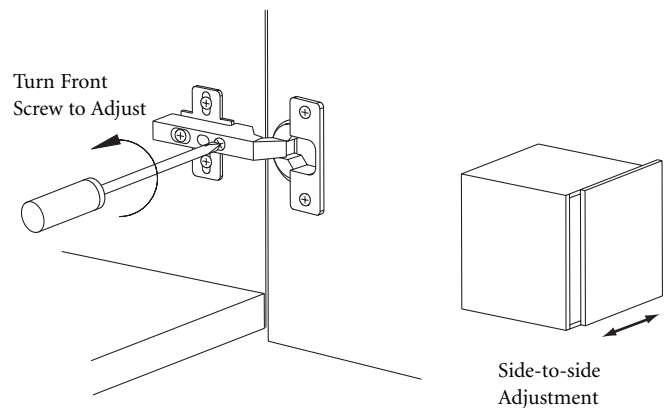
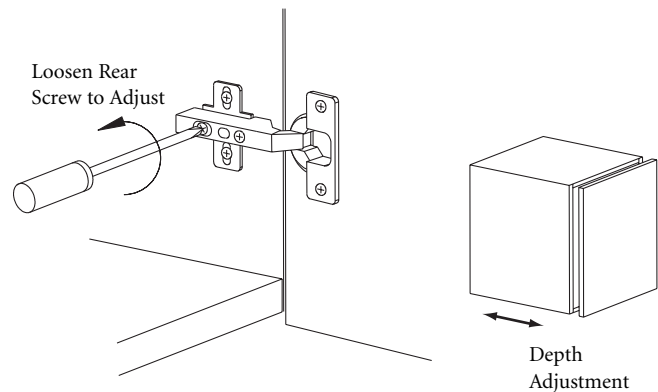

Figure F



Proper product installation, in accordance with these instructions, is the responsibility of the installing agent.
If you have any questions concerning these instructions, please call Kimball Office Customer Care.

Kimball[®]Office

Prevail

Installation (continued)

8. For DOOR HEIGHT ADJUSTMENT: Loosen screws on the hinge mounting plate. Adjust door to desired position and re-tighten screws. (Figure G).
9. Attach return to "U" shaped desk. Reference: Prevail Assembly Instruction "Bridge/Modesty or Return Attachment" for proper procedure. (Figure H).
10. The return will ship with two (2) slide bolts. Install the slide bolts into the pre-drilled holes in the hinged modesty panel. Take care to ensure that the bolts slide in the proper direction. The bolt nearest the "U" shaped desk should engage the gap between the desk end panel and inside door. (Figure I).

Figure G

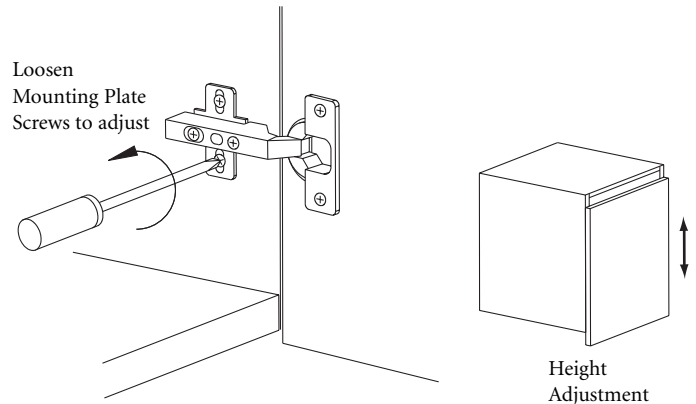

Figure H

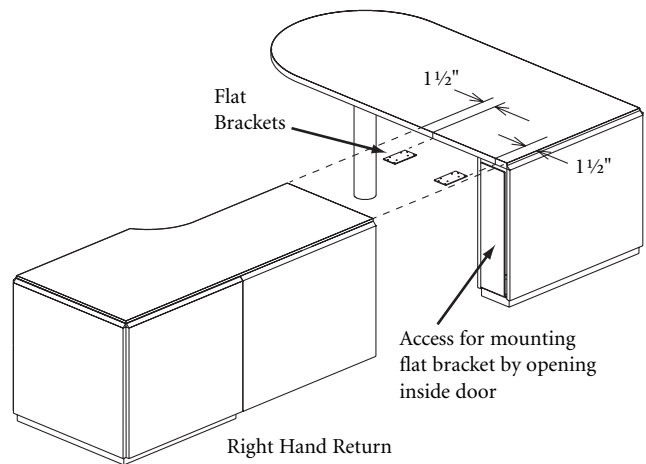

Figure I

