

Innsbruck/Osterley Park

Executive Return

Tools Required

- Level
- #2 Phillips Head Bit
- Tape Measure
- Screw Gun
- Drill Bits

Package Contents

- 16 #10 x 1" Panhead Screws (for flat brackets)
- 2 Flat Brackets
- 10 #8 x 1¼" Panhead Screws (for connecting rail)

Installation

1. The executive return arrives assembled in a carton. It can be attached to a single pedestal desk. (Figure A).
2. Place the desk and return in their desired location. Level both units. Attach the flat brackets to the underside of the main unit at the locations shown, using the provided #10 x 1" panhead screws. Center the flat brackets with the edge of the main unit. (Figure B).
3. Align the return to the main unit. Position the tops so the outer edges of the main and return units are flush and pulled tight against each other with no gaps. Fasten the return top to the flat brackets using the provided #10 x 1" panhead screws. (Figure C).

Note: Flat brackets are shipped on the underneath side of the return top.

Figure A

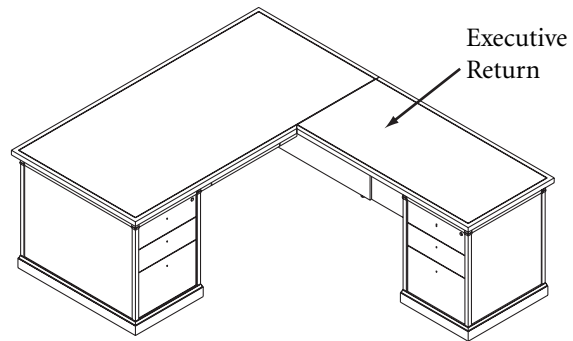

Figure B

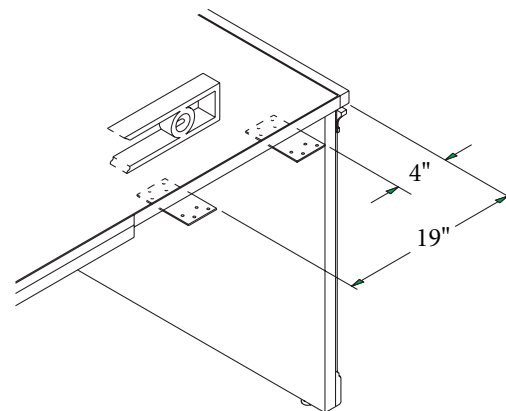
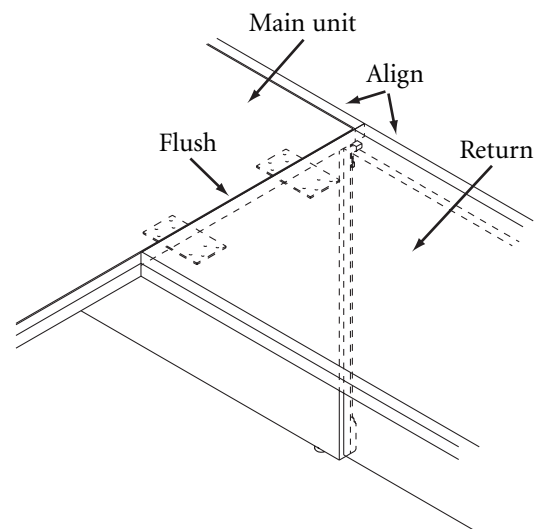

Figure C



Innsbruck/Osterley Park

Installation (continued)

- Align the main unit end panel and the return unit modesty panel to eliminate any gap between them. This can be done by adjusting the levelers up/down on the return or main units. Once any gap is eliminated, attach the main unit to the return unit using the return connecting rail and the #8 x 1¼" panhead screws provided. Re-level units. (Figure D).

Note: Connecting rail is shipped on the underneath side of the return top.

- After unit is assembled, attach the enclosed flat moulding and capital over the seam where the return attaches to the desk. Center the pieces over the seam and attach with enclosed double-sided tape. (Figure E).

Figure D

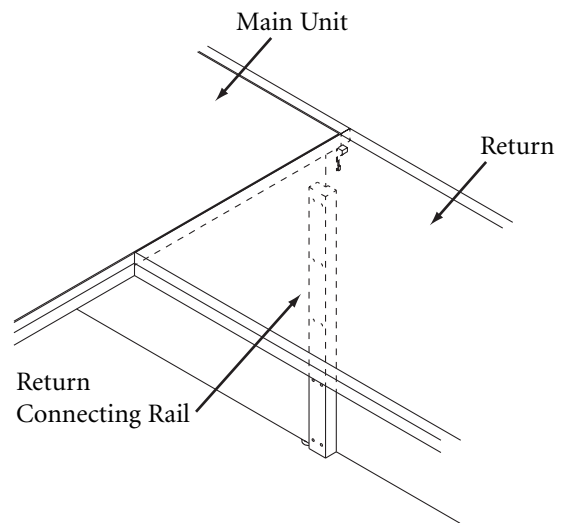

Figure E

