

# President/Senator/Innsbruck/Osterley Park

## Table Desk

### Tools Required

- Level
- 3/4" Socket
- Socket Wrench

### Package Contents

- 1 Table Desk
- 4 Table Leg with Lag Bolt, Washer, Lock Washer and Nut

### Installation

**Note:** This instruction shows the President Table Desk assembly as an example. This instruction can also be applied to Senator and Innsbruck/Osterley Park Table Desk assembly. For safety, and to avoid damage to the unit, it is recommended that more than one person be used to assemble and move the Table Desk.

1. The table desk will arrive unassembled with the legs located on the underneath side of the worksurface. Carefully un-carton and place worksurface face down on a smooth, clean, soft surface. (Figure A).
2. Remove the table legs from the underside of the worksurface and remove all foam packing. Legs are numbered 1, 2, 3, and 4 on their top ends to correspond with their appropriate corner location, which is numbered on the underside of the worksurface. (Figure B).
3. During production, a wooden spacer is fastened to the apron rail where the legs attach. Normally, they are removed before shipment. However, if any spacers remain on the apron rail please remove and discard all of them as they will interfere with installation of the table legs. (Figure C).
4. Locate the table leg numbered "1" and remove the nut, lock washer, and washer from the lag bolt. (Figure D).

Figure A

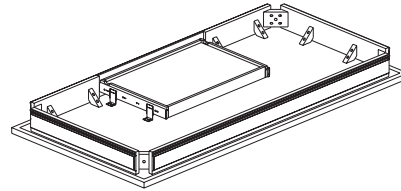

Figure B

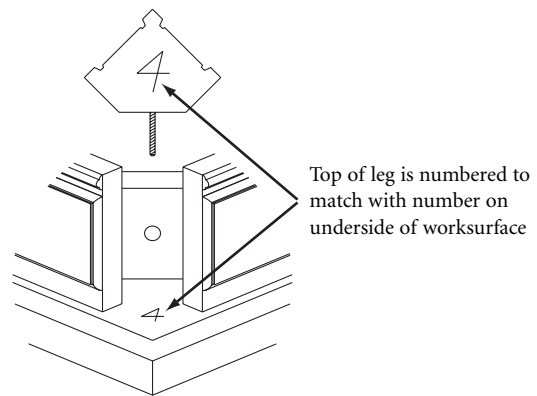

Figure C

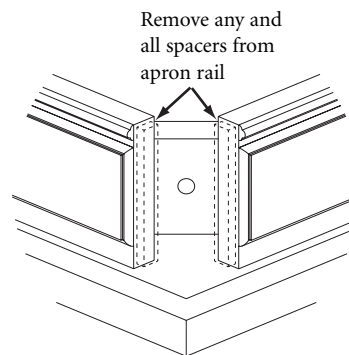
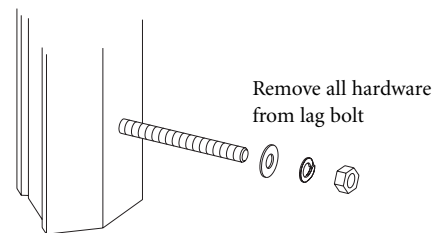

Figure D



# President/Senator/Innsbruck/Osterley Park

## Installation (continued)

5. Insert the lag bolt through the hole in the corner block at the corner numbered "1" on the worksurface. (Figure E).
6. Secure the leg to the table by installing the hardware in the following order: washer, lock washer, nut – to the outside of the corner block. Make sure the leg is perpendicular and flush to the apron rails. Tighten the nut firmly by using the  $\frac{3}{4}$ " socket wrench, but do not over-tighten. (Figure F).
7. Refer to Steps 4, 5, and 6 to install legs "2", "3", and "4" to their corresponding locations. (Figure G).
8. After all legs are installed, carefully turn table to the upright position. If the table displays a swaying motion, then one or more of the legs are not properly seated in their locations. Turn the table back over on the soft surface and re-check all legs to make sure they are perpendicular and flush to the apron rails and that all fasteners are properly installed and tightened. (Figure H).

Figure E

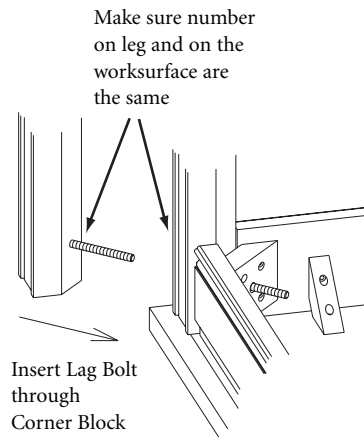

Figure F

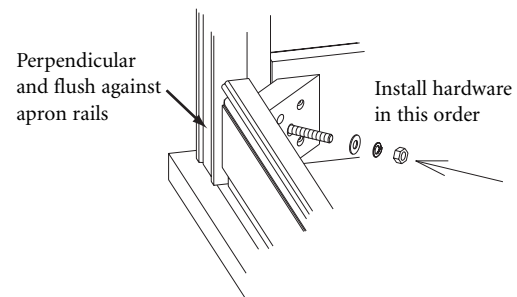

Figure G

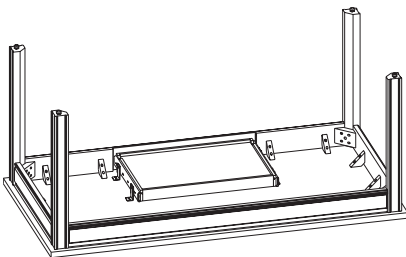

Figure H

