

# President/Senator

## Transaction Shelf

### Tools Required

- #2 Phillips Head Bit
- Cordless Drill

### Package Contents

- 1 Transaction Shelf
- 9 #8 x  $\frac{5}{8}$ " Panhead Screws
- 9 Brackets
- 9 #8 x  $\frac{3}{4}$ " Flathead Screws

### Installation

1. The transaction shelf can be used with the task/reception station. The transaction shelf can be positioned on either the left or right hand side of the station. The shelf rests **ON TOP** of the 43" high panels (not inset). (Figure A).
2. The transaction shelf is fastened to the station using the provided brackets and screws. The brackets mount flush with the top edge of the 43" high panels. The front brackets mount 10" off the inside edge of the station. The back brackets should be spaced about every 12". Fasten the brackets to the 43" high panels using the provided #8 x  $\frac{5}{8}$ " panhead screws. (Figure B).
3. Place the transaction shelf on top of the 43" high end panels. Position the shelf so that it overhangs all edges equally. Fasten the shelf to the brackets using the provided #8 x  $\frac{3}{4}$ " flathead screws. (Figure C).

Figure A

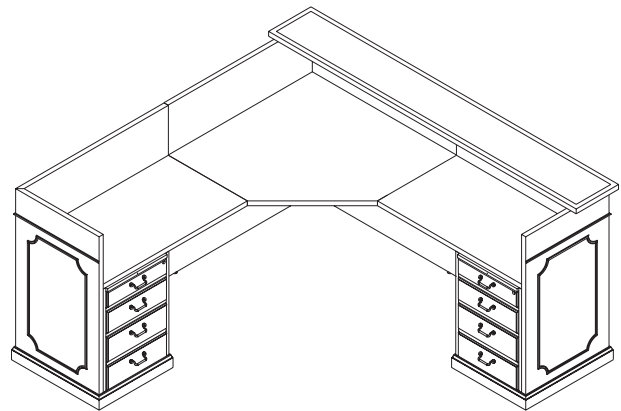

Figure B

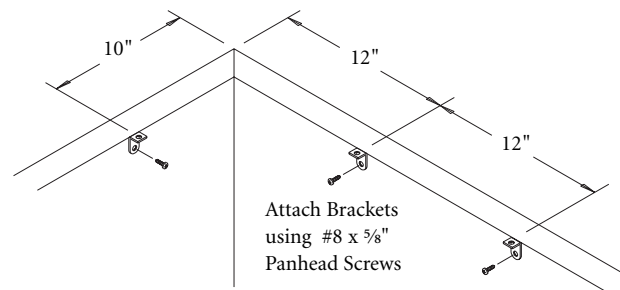

Figure C

