

# President/Senator

## Drawer Removal, Adjustment, and Unit Leveling

### Tools Required

- 7/32" Nutdriver
- Phillips Screwdriver
- Level
- Tape Measure or Ruler

### Installation

1. For Desk, Credenza, Return, Bridge, Lateral File & Drawer or Door Storage and Bookcases as applicable: Remove all drawers as required to access leveling glide adjustment holes.
  2. To remove drawers: Extend the box or file drawer to its full extension. Locate the drawer slide release tab, in the approximate location shown, on each side of the drawer box. Press both tabs in and pull drawer straight out until slide drawer members disengage from cabinet members. (Figure A).
  3. To remove lateral file drawers, extend the drawer forward. (Figure B). Press the two quick-disconnect release tabs and lift the drawer off the slide assembly. (Figure C).
- Note:** Shipping screws must be removed from drawer suspensions before drawer can be removed.
4. Turn the leveling glides fully "in" (counterclockwise) prior to leveling. Level the unit from front to back by first extending the glides on the outside corners (turn clockwise), then level the unit from side to side. Check adjustments by placing the level at the four positions shown. Adjust inside glides, if applicable, to help support the unit. (Figure D).
  5. Replace all drawers to their original locations. To re-install, fully extend cabinet slide members, making sure the chrome ball-bearing members are also forward. Carefully align drawer slide members with cabinet slide members and gently push drawer closed. Check for proper alignment by inspecting drawer front margins for spacing and squareness.

Figure A

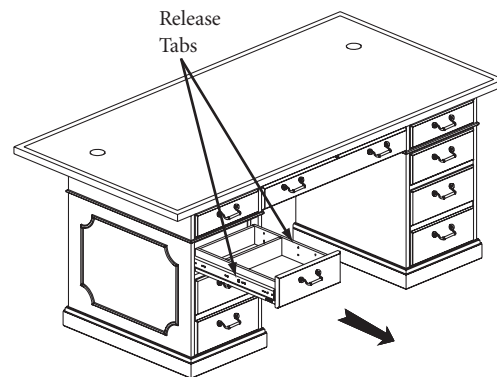

Figure B

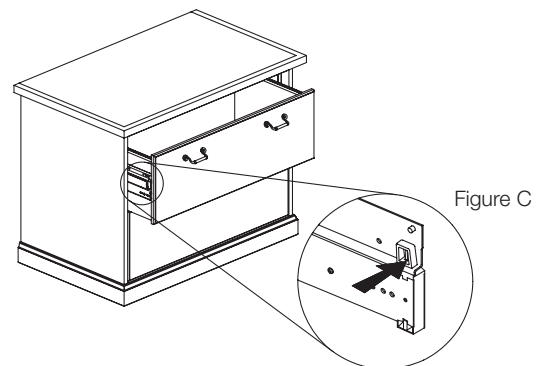
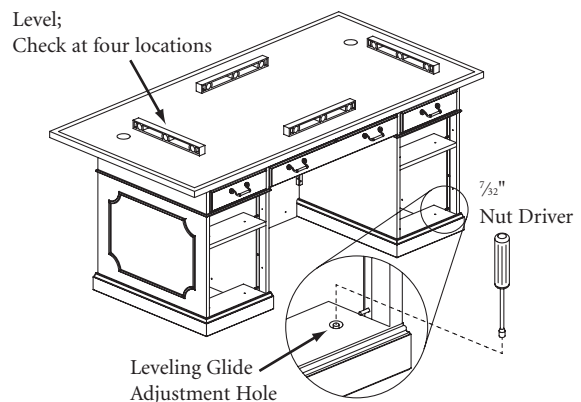

Figure D



# President/Senator

## Installation (continued)

6. If drawer front needs adjustment, open drawer and locate the four (4) Deerwood screws that attach the drawer front to the drawer box. (Figure E).

**Note:** *Lateral file drawer fronts use six (6) screws.*

7. Slightly loosen Deerwood screws and adjust drawer front to the approximate locations and gaps shown. (Figure F). Re-tighten all Deerwood screws. Repeat Steps 6 and 7 to adjust other drawers in unit.

Figure E

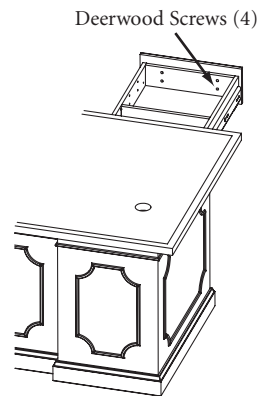

Figure F

