

Wireway Cover

Tools Required

- Flat Head Screwdriver

Installation

Note: Three types of wireway covers are available—with no power or data access, with power access, and with power and data access. With no power or data access wireway covers are generally used in highly visible areas. With power access and with power and data access wireway covers are used where receptacles, power entries, or data ports are required.

1. Slide open receptacle covers toward center where required. (Figure A).
2. Start in a corner. Engage bottom of flange of cover under wireway bracket on both verticals. Swing cover up and press top flange over top of brackets on both verticals. (Figure B). Use a flat top screwdriver with the tip pressed into the floor and raise the screwdriver so that it lifts the bottom flange along with the wireway bracket. The top flange will snap over the wireway bracket.

Figure A

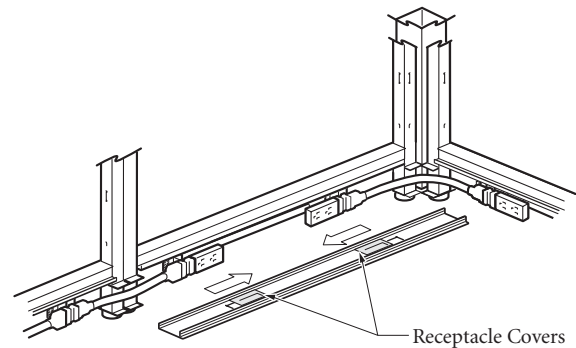

Figure B

