

President/Senator

Bridge Unit

Tools Required

- Level
- Tape Measure
- #2 Phillips Head Bit
- Screw Gun
- Drill Bits

Package Contents

- 4 Flat Brackets
- 2 Align-n-lock Fasteners
- 4 Hinges
- 44 #10 x 1" Panhead Screws
- 4 #8 x 5/8" Panhead Screws

Installation

1. The hinged modesty/bridge unit arrives un-assembled in a carton. Place the bridge face down on a smooth, hard surface. Take care to not mar the worksurface. (Figure A).
2. The bridge and modesty panel have pre-drilled holes used to attach the two units together with supplied hinges. Attach the hinge to the modesty panel using three #10 x 1" panhead screws in each hinge. Attach the modesty panel to the bridge using three of the provided #10 x 1" panhead screws in each hinge. (Figure B).
3. Turn the bridge assembly upright. The bridge assembly can be mounted between a single pedestal desk and credenza. (Figure C).

Figure A

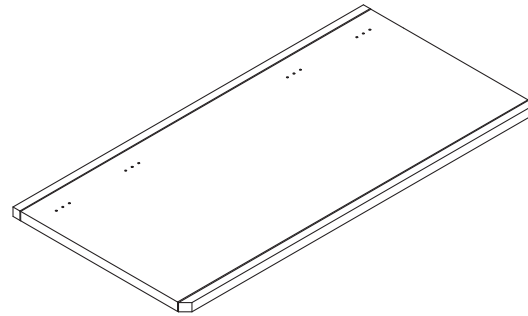

Figure B

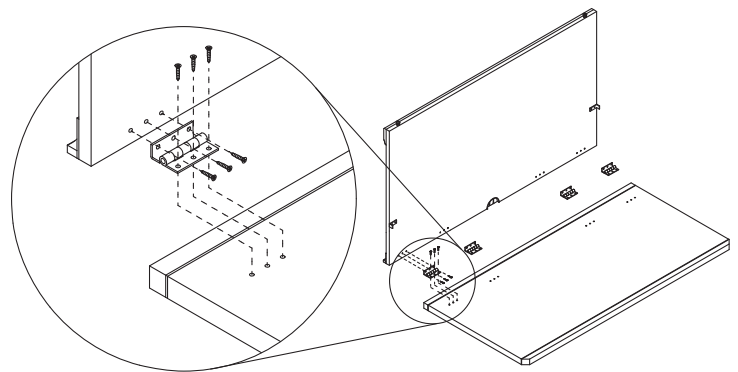
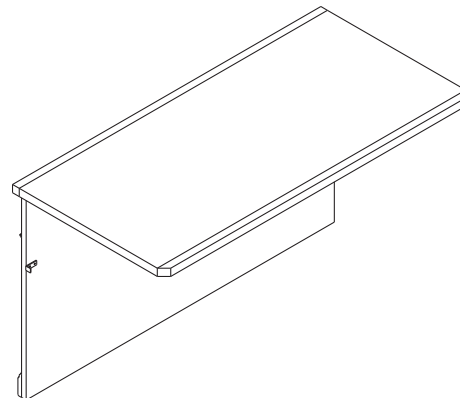

Figure C



President/Senator

Installation (continued)

- Position the main units in the desired locations. Leave enough space between the two units to allow for placement of the bridge. Level main units. Install the flat brackets to the undersides of the main units using the provided #10 x 1" panhead screws. Locate the flat brackets using the dimensions shown. Center the brackets with the edge of the unit worksurfaces. (Figure D).

Note: Flat brackets are shipped on the underside of the bridge top.

Use the pre-drilled holes in the desk end panel to mount the quick align-n-lock fastener using the #8 x 5/8" panhead screws. (Figure D). Fastener is shipped in the bridge hardware bag.

- Align the bridge worksurface to the main units. Position the tops so the outer edges of the main units and bridge worksurface are tight and flush against each other with no gaps. Attach the bridge worksurface to the flat brackets using the provided #10 x 1" panhead screws. (Figure E).
- Level all units. Align all margins vertically between the modesty panel and desk/credenza end panels. Eliminate all gaps. Engage quick align-n-lock fasteners on lower portion of modesty panel and rotate latch handles firmly. (Figure F). Adjust levelers on modesty panel snug to floor.

Note: Do not over-tighten levelers, otherwise units will become mis-aligned. (Figure G).

Figure D

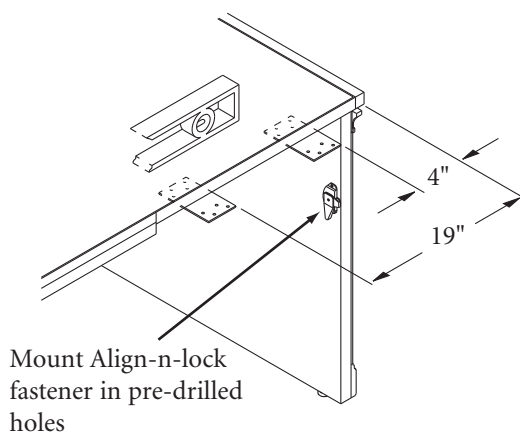

Figure E

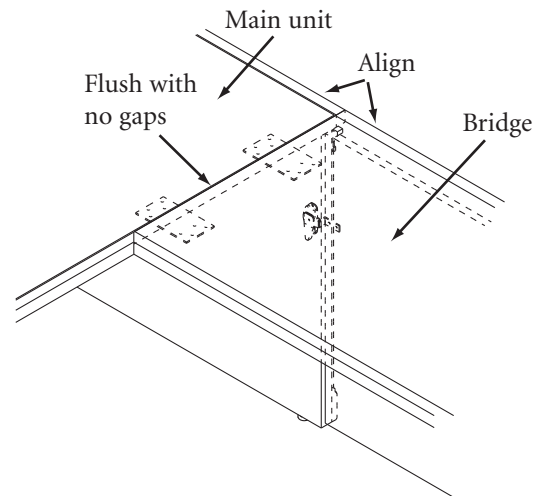

Figure F

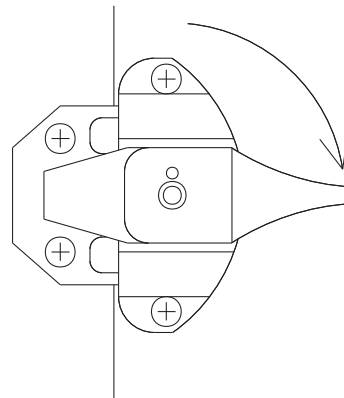

Figure G

