

Definition[®]

Modular Worksurfaces

Tools Required

- Tape Measure
- #2 Phillips Head Bit
- Screw Gun
- Level

Hardware Required

- #10 x 1" Panhead

Installation

1. Modular worksurfaces can be used alone, or in combination with pedestals, modesty panels, end panels, or support panels to make any desired configuration. (Figure A).
2. Position the main unit in the desired location. Level main unit. Install the flat brackets to the main unit using #10 x 1" panhead screws provided. (Figure B).
3. Align the worksurface to the main unit. Position the tops so the outer edge of the main unit and return unit are flush and pull tight against main unit. Fasten return top to the flat brackets using #10 x 1" panhead screws provided. (Figure C).

Figure A

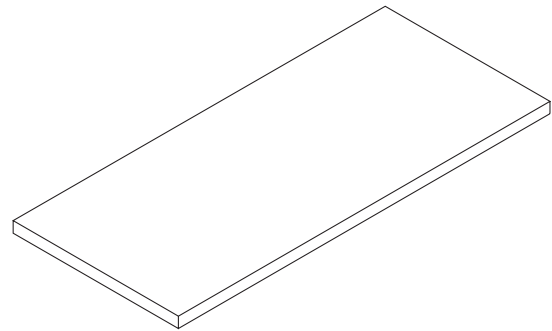

Figure B

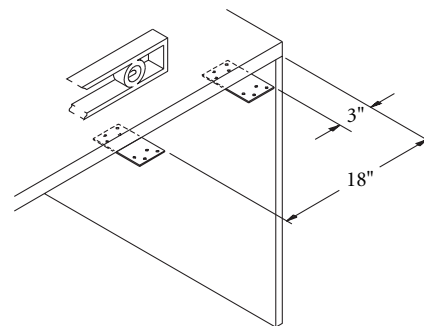

Figure C

