

Definition®

Task Transaction Shelf

Tools Required

- #2 Phillips Head Bit
- Tape Measure
- Screw Gun

Hardware Required

- #8 x $\frac{5}{8}$ " Panhead
- #8 x 1" Flathead
- Bracket

Installation

1. The transaction shelf can be used with the task/reception station. The transaction shelf can be positioned on either the right or left hand side of the station. The shelf rests on top of the 43" high panels. (Not inset). (Figure A).
2. The transaction shelf is fastened to the task station using the brackets and #8 x $\frac{5}{8}$ " panhead screws provided. The bracket mounts flush with the top edge of the 43" high panel. The front brackets mount 10" off the inside edge of the station. The back brackets should be spaced about every 12". Fasten in position. (Figure B).
3. Locate the transaction shelf on top of the 43" high end panels. There should be a $\frac{3}{32}$ " margin where the top overhangs the task/reception station. Fasten shelf to station using #8 x 1" flathead screws provided. (Figure C).

Figure A

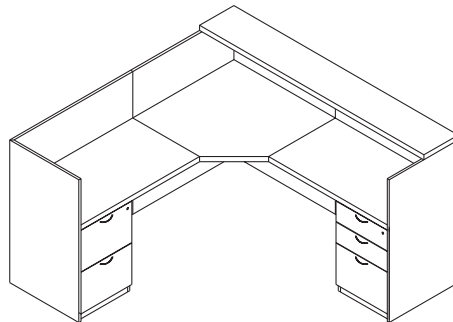

Figure B

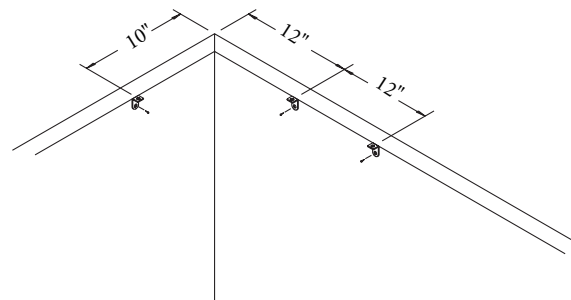

Figure C

