

# Universal Products

## Support Bases

### Tools Required

- #2 Phillips Head Bit
- Tape Measure
- Screw Gun

### Hardware Required

- #8 x 5/8" Panhead
- #8 x 1" Flathead
- Bracket

### Installation

1. Support bases are used to provide support for any worksurface shape. (Figure A).
2. To install, place worksurface on a clean, soft surface, underside facing up. Mark the center of the radius where the base attaches. Attach base to worksurface using #8 x 1" flathead screws and the #8 x 5/8" panhead screws provided. (Figure B).

Figure A

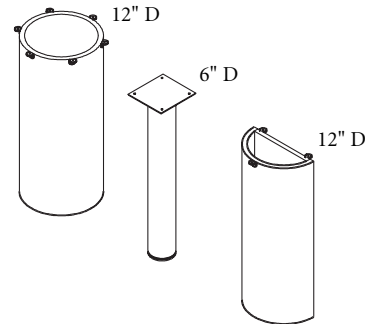

Figure B

