

Pedestal Drawer Removal

Tools Required

- None

Installation

1. Extend the box or file drawer to its full extension and remove shipping screw from drawer slide.
2. Locate the drawer slide release tab on each side of the drawer box. Press the tabs in and pull drawer up and out until slide drawer members disengage from cabinet members. (Figures A and B).
3. To reinstall drawer, extend slide cabinet members to full extension. Set drawer slide member on extended slide making sure back end of drawer slide member is under locator tab on extended slide. Push drawer down until release tabs snap into place. Gently push drawer closed. Check for proper alignment by inspecting drawer front margins for spacing and squareness. (Figure B).

Figure A

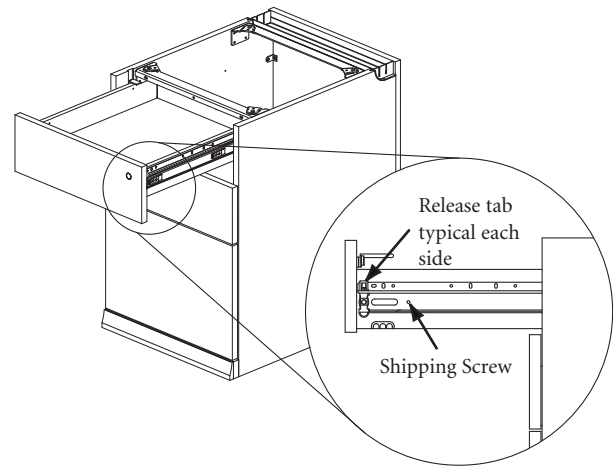

Figure B

