

# Unfold 4-Piece Folding Tables

## Tools Required

- Utility Knife
- #3 Allen Wrench

## Package Contents

- 4-piece Folding Table

## Installation

1. Position folded table in desired location. Cut all plastic ties from table frame, springs, and undersurface cabling. (Figure A).
2. To unfold table, open only one section of the table at a time. Pull outward on the outer section at one end of the table. Push down on the middle areas of the worksurfaces. Be careful to keep hands away from pinch points. (Figure B).  
**Note:** *If both sections of the table are folded/unfolded at the same time, the worksurfaces will be damaged.*
3. Table section will stop unfolding when worksurface pieces are horizontal. (Figure C).
4. To lock table section in position, firmly pull locking handles out and turn handle ends away from each other so that the handles are parallel to the bottom side of the worksurface. Release handles to allow them to snap into the locked position. (Figure D).  
**Note:** *Locking handles are on both sides of the table. Make sure all handles are in the locked position before using table.*

Figure A

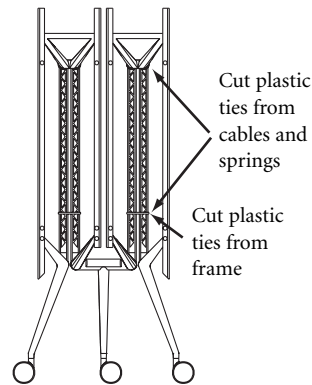

Figure B

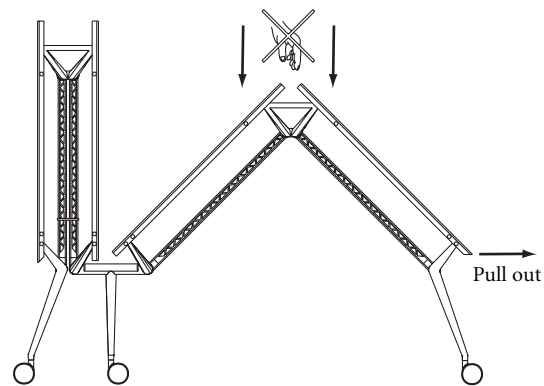

Figure C

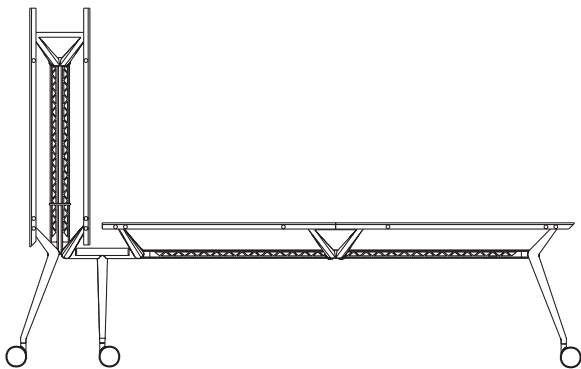
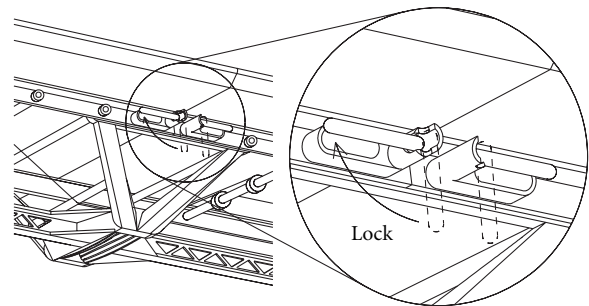

Figure D



# Aspire

## Installation (continued)

5. Follow Steps 2, 3, and 4 to unfold and lock the other section of the table. (Figure E).
6. To unlock table, firmly pull locking handles out and turn handles down until they are perpendicular to the worksurface. Release handles, making sure they remain in the unlocked position. Remember that locking handles are on both sides of the table. Make sure all handles are unlocked before folding table. (Figure F).
7. If the center area of the worksurface is uneven when the table is in the open position, the worksurfaces can be adjusted with set screws located under and behind the locking handles on each side of the table. (Figure G).
8. Check worksurfaces for unevenness. (Figure H).
9. Use the #3 Allen wrench to adjust set screws up or down until worksurfaces are flush. Adjust on both sides of table, if necessary. (Figure I).

Figure E

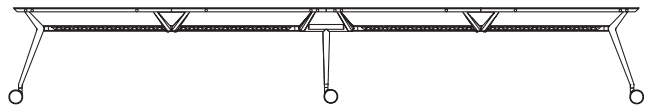

Figure F

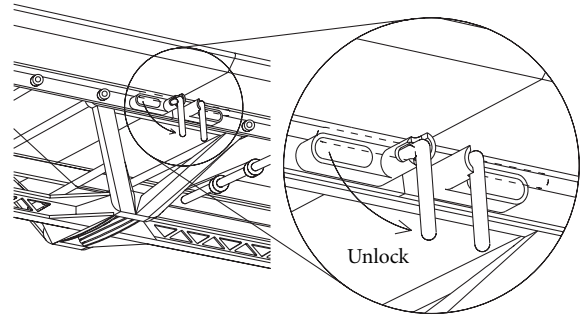

Figure G

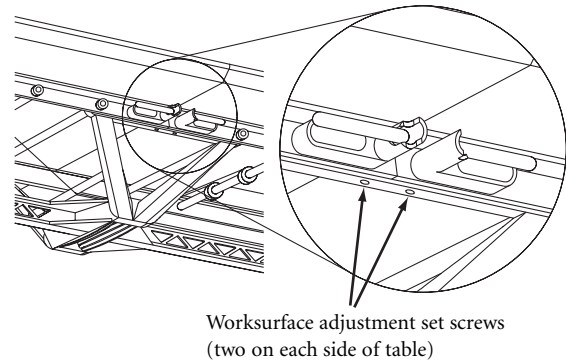

Figure H

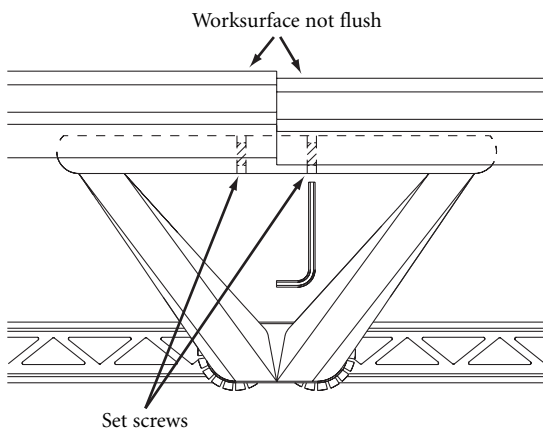
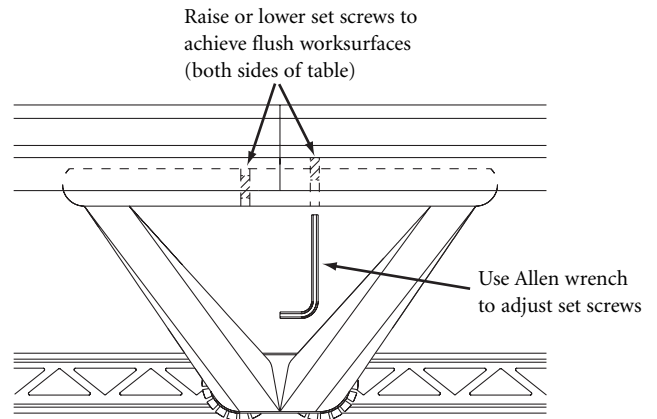

Figure I



Printed in U.S.A. © 2003 Kimball International, Inc. T 800.482.1818 F 812.482.8300

Proper product installation, in accordance with these instructions, is the responsibility of the installing agent. If you have any questions concerning these instructions, please call Kimball Office Customer Care.

Kimball<sup>®</sup>Office