

Aspire®

## Replacement of Gears in Folding Table Center Mechanism

### Tools Required

- Flat Head Screwdriver
- Rubber Mallet
- Electric Screwdriver with #4 Hex Drive
- Long-Nose Pliers
- Set of metric Allen Wrenches
- Lubriplate, Vaseline, or other similar lubricant

### Package Contents

- 2 Gear (Left and Right)
- 2 Location Pin
- 2 Pivot Ring
- 1 Male/Female Fastener

### Installation

**Note:** These instructions provide basic information for installing replacement gears in the folding table center mechanism. For safety purposes and to avoid damage and/or injury, it is recommended that two or more persons be used to move the wood tops, and that the wood tops be removed/installed with the base in the upright position.

**Note:** If a gear is being replaced at the end of the table, it will not be necessary to remove the center heart mechanism as outlined in steps 3, 4, 5, and 6. Follow steps 1 and 2, but modify to remove the top only from the side that is being replaced. Table will still need to be in folded position as per step 2, but you will only be required to remove leg on one side to replace gear. Continue with steps 7 through 17 as they apply to this situation.

**Note:** For ease of replacement and re-assembly, gears should only be replaced one side at a time. Determine which gear(s) is/are damaged before starting repairs.

1. Make sure table is fully open and locked. Use the electric screwgun with #4 hex bit to remove screws holding worksurfaces to table frame. Save all removed screws. (Reference Aspire Assembly Instruction: “Mount Wood Top to Table Base Understructure”). Carefully remove worksurfaces from frame and set aside. Unlock frame and move to fully folded position. (Figure A).

2. Use the long-nose pliers to remove the clevis pin from one of the turnbuckles attached to the “H” bracket at the bottom of the frame. Remove one of the springs from the “H” bracket. Loosening these items removes tension from the cables that pass through the center mechanism. (Figure B).

Figure A

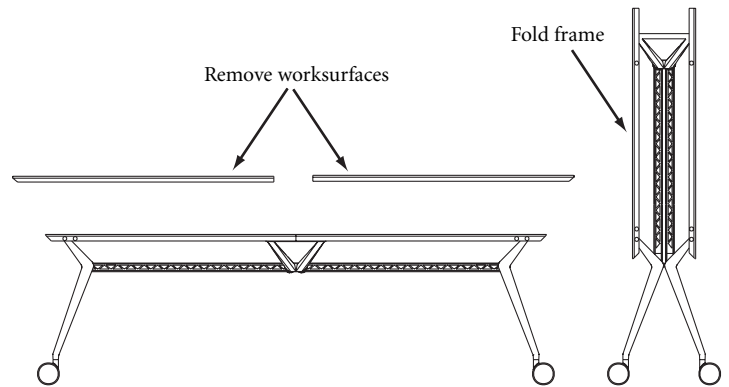
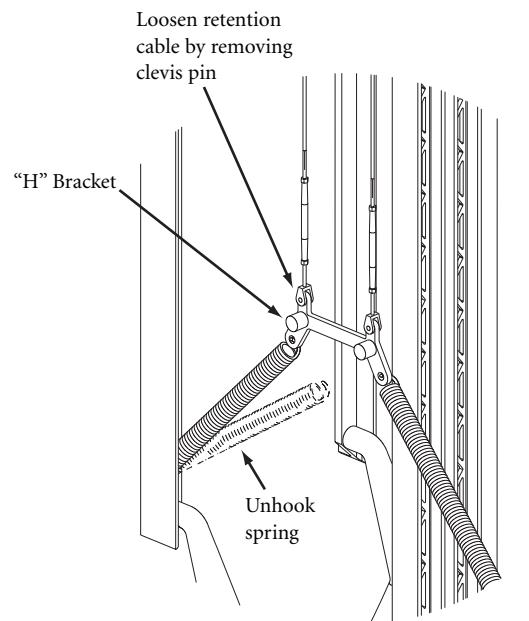

Figure B



# Aspire

## Installation (continued)

3. Begin on the frame side of the first gear(s) to be replaced. If the frame utilizes the “bayonet” style frame lock (with orange button), it must be removed first to expose the screws beneath it. (Figure C). Save all screws that attach lock mechanism to rails. Remove and save all screws and washers holding center “heart” mechanism and cable bars in place. (Figure D).
4. Pull both rails loose and pivot them away from the center. (Figure E).
5. Use an Allen Wrench to remove both set screws from the bottom of the chrome-finished “heart”. Retain the set screws. (Figure F).

Figure C

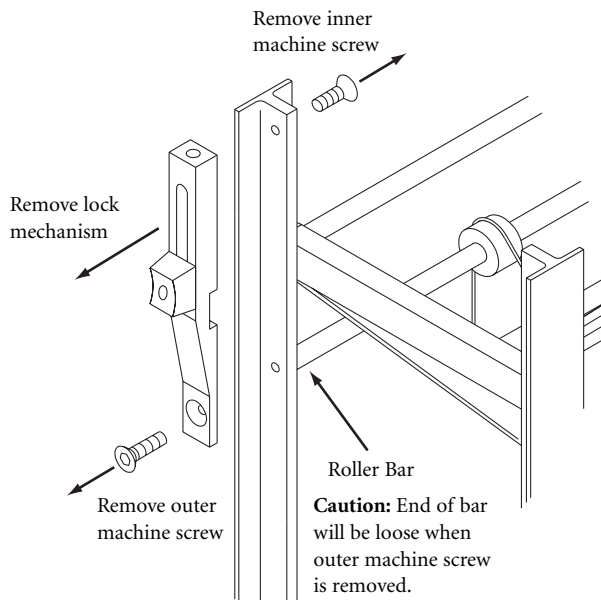

Figure D

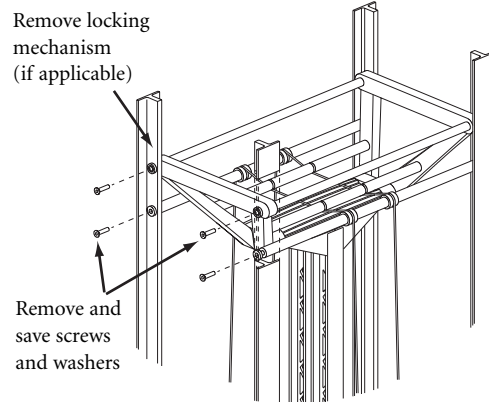

Figure E

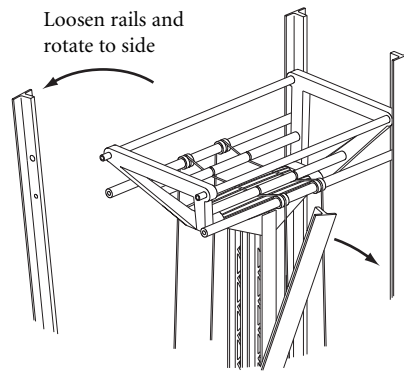
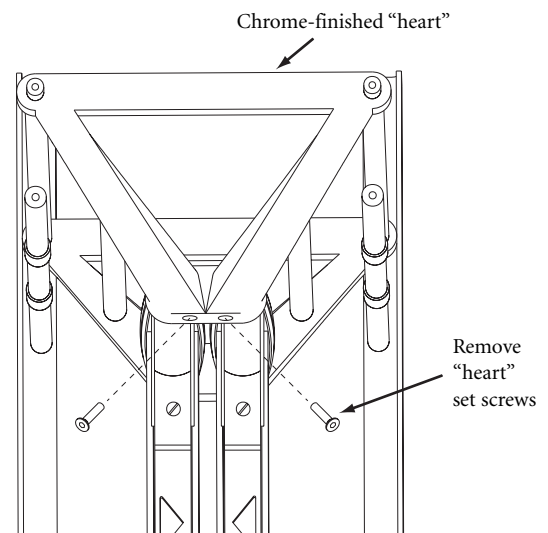

Figure F



# Aspire

## Installation (continued)

6. Pull “heart” away from center mechanism. Take care that no other bars or cables are dislodged. (Figure G).
7. Use flat screwdriver and Allen Wrench to remove Male/Female fastener from damaged gear. Discard fastener pieces. (Figure H).
8. Remove damaged gear from center support tube. (Figure I).
9. Insert new pivot ring into recess in new replacement gear. If necessary, tap ring lightly with rubber mallet to fully seat ring into gear. Take care to not damage ring or gear.

**Important:** Gears in center mechanism **MUST** mesh properly for correct folding action. Test fit, if necessary, to make sure chosen replacement gear is an exact mirror match of gear on opposite side of center rail. Improperly matched gears will cause center mechanism malfunction and could cause additional damage. (Figure J).

Figure G

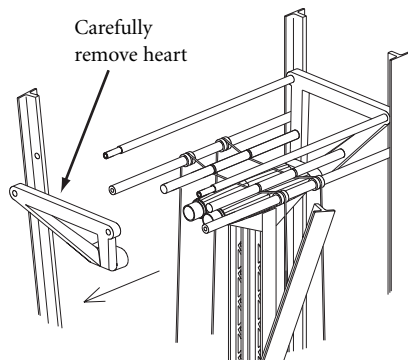

Figure H

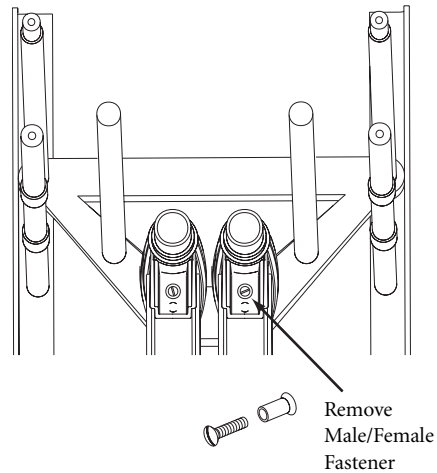

Figure I

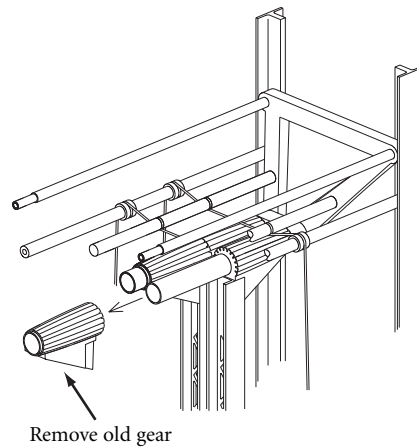
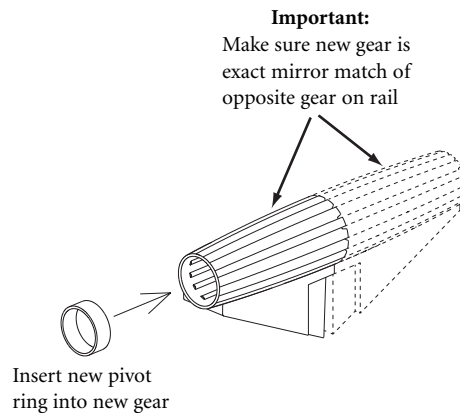

Figure J



# Aspire

## Installation (continued)

10. Remove old locating pins in center rail and replace with new pins from package (two required). (Figure K).  
**Note:** *If opposite gear has already been replaced during this work session, the locating pins are still good.*
11. Apply small amount of Lubriplate, Vaseline or other similar lubricant to center portion of support tube. Slide new gear/ring assembly onto support tube and fully seat assembly against center rail. Make sure assembly fully engages locating pins. (Figure L).  
**Note:** *Re-check gear to make sure it is a match for the gear on the opposite side of the rail.*
12. Attach gear/ring assembly to center rail with new male/female fastener. Fastener inserts into both sides of center rail. Tighten fastener firmly, but do not over-tighten. (Figure M).
13. Make sure all cabling and support bars are in their approximate correct positions. Carefully match up holes and recesses and re-install “heart” mechanism onto bars and support tubes. Use rubber mallet to fully seat “heart” into position. Re-install the two set screws in the bottom of the “heart”. (Figure N).

Figure K

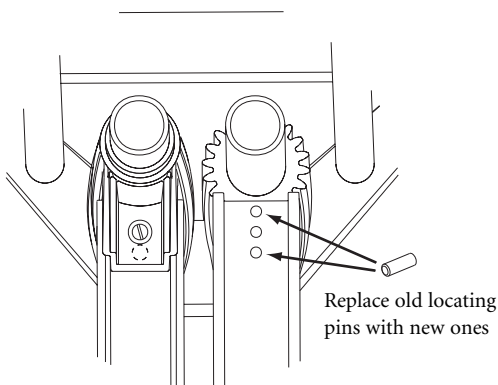

Figure L

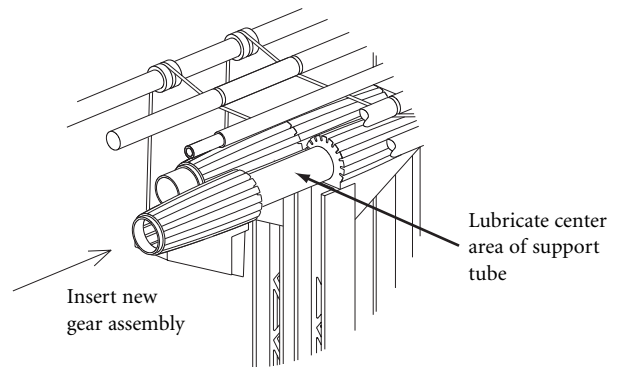

Figure M

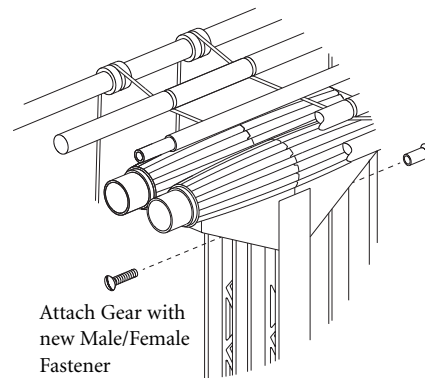
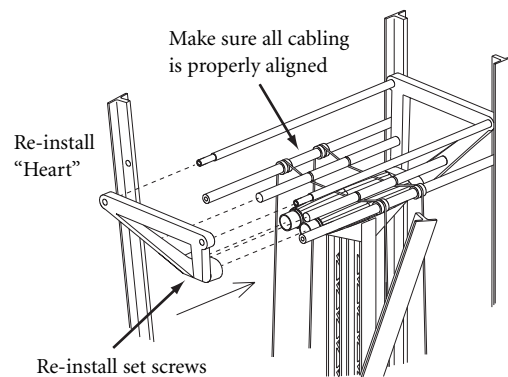

Figure N



# Aspire

## Installation (continued)

14. Rotate side rails upward and carefully re-install them into original position on cable bars. Use original screws and washers to firmly secure rails. If applicable, re-install "bayonet" style frame lock to rails using saved screws. (Figure O).
15. Re-fold table frame and re-attach spring and turnbuckle devis to "H" bracket. Use care while springs are re-tensioned. (Figure P).
16. Carefully operate table mechanism to check for proper gear mesh and bar operation with no binding or other obvious malfunction. (Figure Q). If any gear(s) on opposite side of frame must be replaced, repeat Steps 3 through 15.
17. Unfold table frame and lock into position. Take care to keep hands out of frame "pinch-points" while unfolding. Re-attach worksurfaces to frame using saved screws. (Figure R).

Figure O

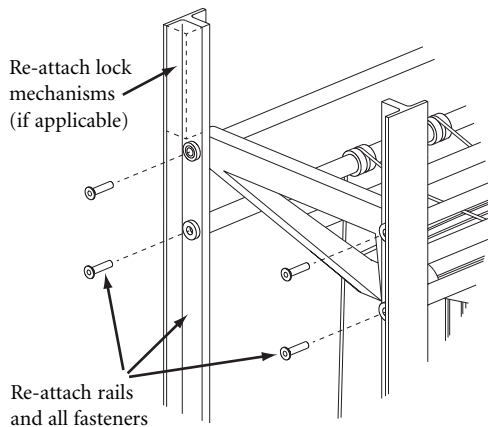

Figure P

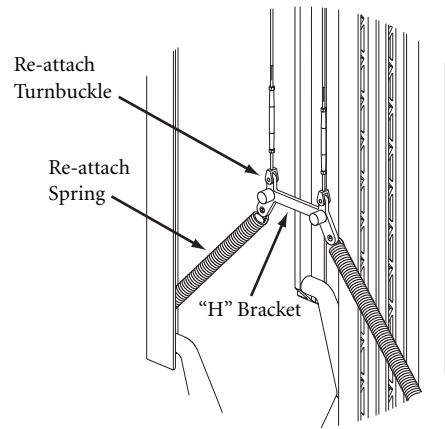

Figure Q

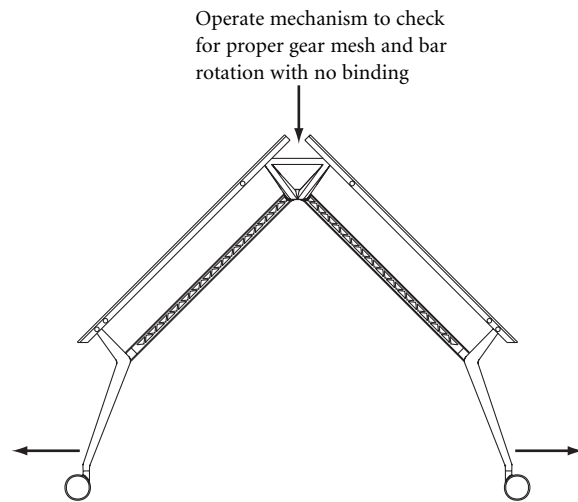
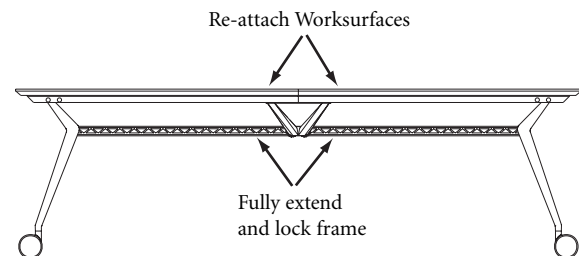

Figure R



Printed in U.S.A. © 2005 Kimball International, Inc. T 800.482.1818 F 812.482.8300

Proper product installation, in accordance with these instructions, is the responsibility of the installing agent. If you have any questions concerning these instructions, please call Kimball Office Customer Care.

Kimball<sup>®</sup>Office