

# 1-Piece Static Table Top Replacement

## Tools Required

- Phillips Screwdriver
- Electric Screw Gun with Phillips Bit

## Package Contents

- 1-Piece Replacement Top
- Worksurface Clamps

## Installation

**Note:** This instruction explains basic installation of Aspire 1-piece static replacement tops.

**Caution:** There are factory-installed locating screws inserted on the underside of the replacement top at each end. The locating screws aid in the correct positioning of the top on the table frame. Driving the locating screws all the way in **WILL CAUSE DAMAGE** to the topside worksurface. The manufacturer is not responsible for any damage caused by driving the locating screws in. (See Figure C for example of locating screw position).

1. Make sure table is in upright position on a level, solid surface. (Figure A).
2. Remove the table top from the frame. Older model table tops are attached to the frame with screws. Newer model table tops are attached to the frame with clamps. On older model tops, remove all screws holding the top to the frame. Discard screws and remove top from frame. On newer model tops, release all clamps holding top to frame by pulling downward on each clamp lever. Lift top straight up to remove. (Figure B).

Figure A

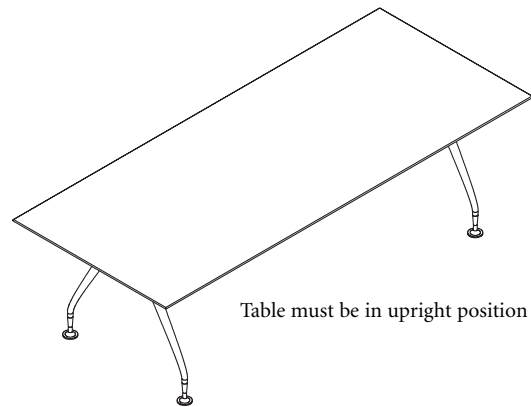
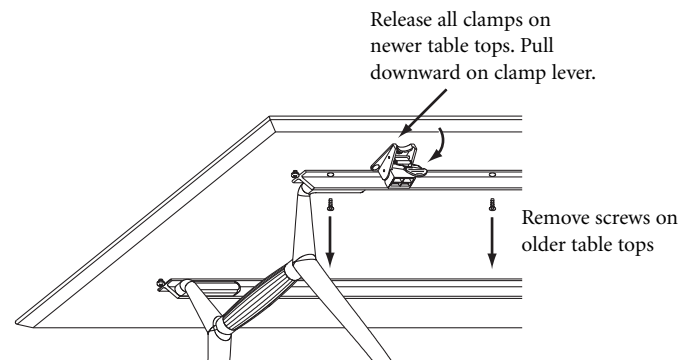

Figure B



# Aspire

## Installation (continued)

3. Carefully unpack replacement top and place it face down on a smooth, hard surface. Take care to not mar the work surface. The work surface has factory-installed clamps on the underside. Raise the levers on all the clamps to put them in the “release” position (See Detail 1 in Figure C). **DO NOT** tighten the locating screws. (Figure C). (See cautionary note above). Check each clamp to make sure the plastic gasket is in place in its groove in the clamp mechanism (See Detail 2 in Figure C).
4. Carefully turn top upright. Lower top onto frame, centering it between the clamps and locating screws. Make sure top is flush against the table frame and is not resting on any portion of any clamp or on any locating screw. (Figure D).
5. When top is positioned correctly, carefully re-check each clamp to make sure the plastic gasket is in its groove in the clamp mechanism. Lock each clamp by firmly rotating the release lever towards the replacement top. (Figure E).

Figure C

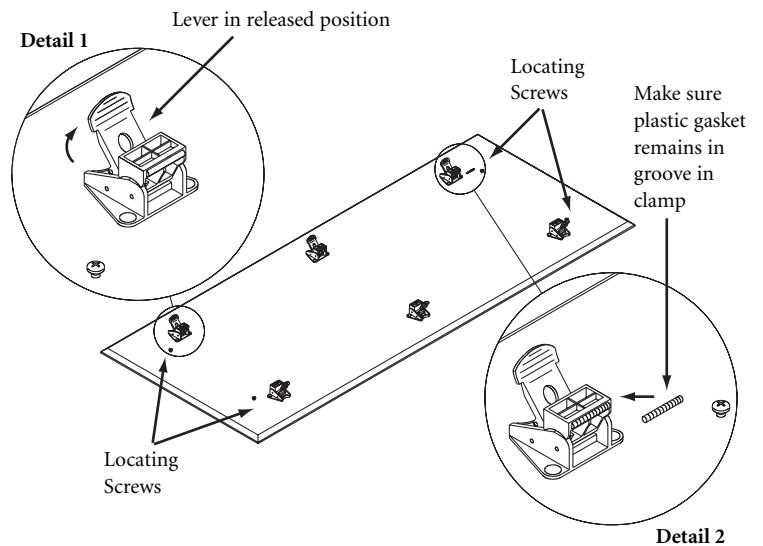

Figure D

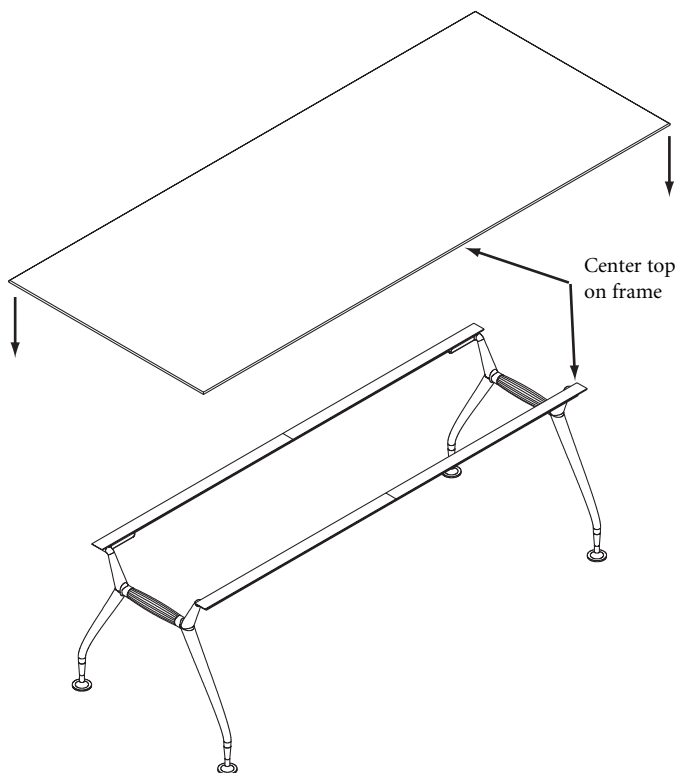
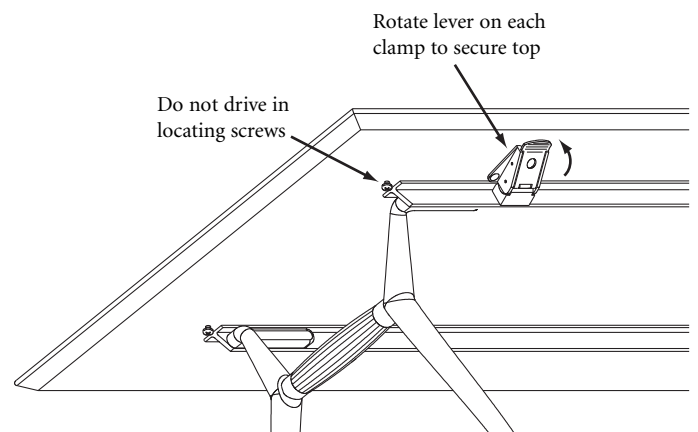

Figure E



Printed in U.S.A. © 2004 Kimball International, Inc. T 800.482.1818 F 812.482.8300

Proper product installation, in accordance with these instructions, is the responsibility of the installing agent. If you have any questions concerning these instructions, please call Kimball Office Customer Care.

Kimball Office