

Aspire®

Attach Legs to Non-Folding Table

Tools Required

- #5 Hex Drive
- Adjustable Wrench

Package Contents

- Table/Frame Assembly
- Glides or Casters
- Non-Folding Legs

Installation

Caution: There are factory-installed locating screws inserted on the underside of the table worksurface at each end. The locating screws aid in the correct positioning of the top on the table frame and the customer/installer should **NOT** tamper with these locating screws at any time. Driving the locating screws all the way in **WILL CAUSE DAMAGE** to the topside worksurface. The manufacturer is not responsible for any damage caused by driving the locating screws in. (See Figure D for example of locating screw position).

1. Place table/frame assembly face down on a smooth, solid surface. Be careful to not mar the worksurface. (Figure A).
2. Remove mounting hardware from each leg. (Figure B).
3. The center tube of each leg mounts to the frame tube at each end of the table frame. The flange of each leg mounts to the inside of the T-beam. The hole on the flange must align with its corresponding hole in the T-beam. (Figure C). Make sure each leg aligns correctly with its mounting holes. If the flange does not align with a mounting hole, the leg must be moved to a different position on the frame. (Figure D).

Figure A

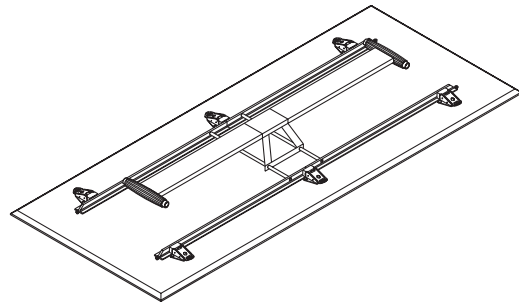

Figure B

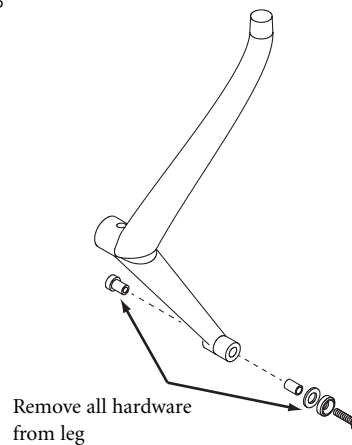
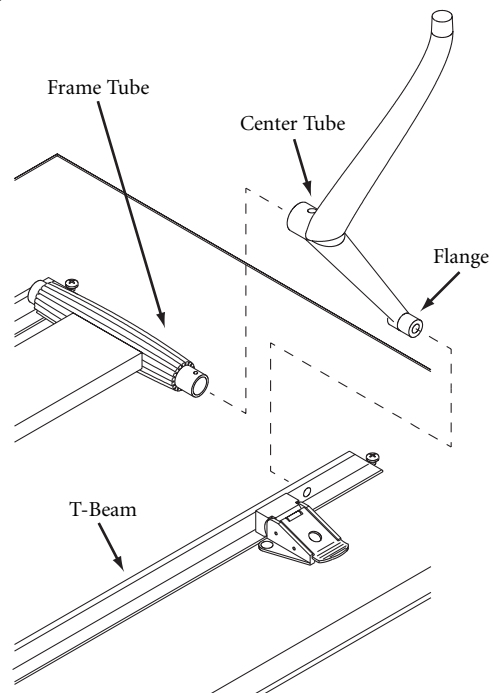

Figure C



Proper product installation, in accordance with these instructions, is the responsibility of the installing agent. If you have any questions concerning these instructions, please call Kimball Office Customer Care.

Kimball®Office

Aspire

Installation (continued)

4. Use the bolt to attach the leg center tube to the frame tube. Do not fully tighten. (Figure E). Attach hardware to leg frame and table frame as shown in Figure E, making note of positions of all bolts and washers. Tighten all bolts securely. **DO NOT** tighten the locating screws. (See cautionary note above).
5. Repeat Steps 3 and 4 to mount remaining legs. Tighten all bolts securely. (Figure F).

Figure D

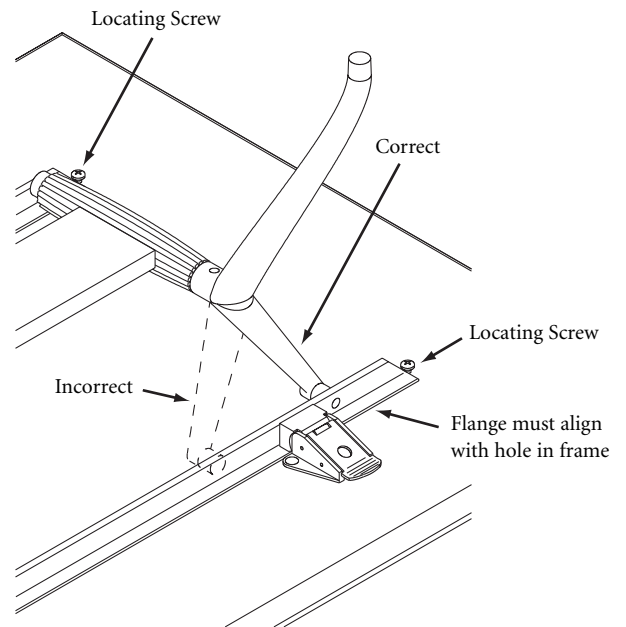

Figure E

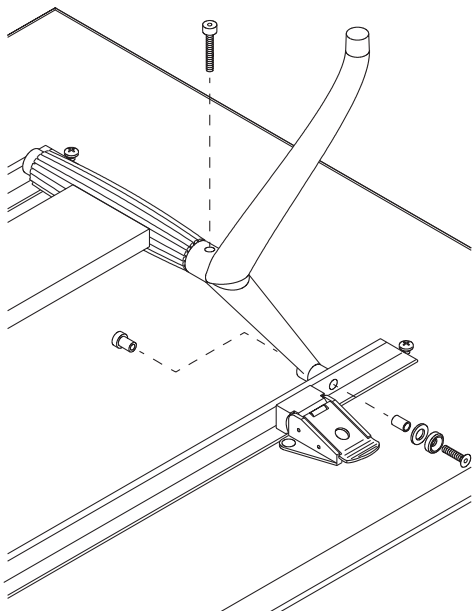
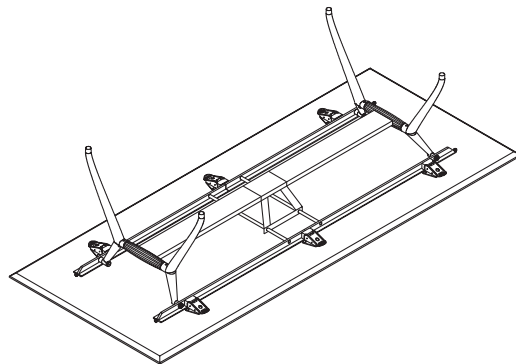

Figure F



Proper product installation, in accordance with these instructions, is the responsibility of the installing agent. If you have any questions concerning these instructions, please call Kimball Office Customer Care.

Kimball[®]Office

Aspire

Installation (continued)

6. Insert glides or casters. Glides and casters screw into the bottom of the legs. (Figure G).
7. Carefully turn table to upright position. (Figure H).

Figure G

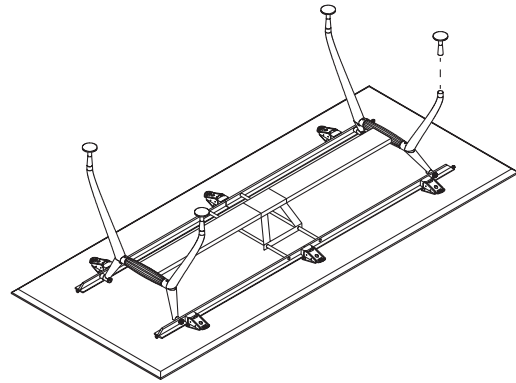

Figure H

