

# Mount Wood Top To Table Base Understructure

## Tools Required

- #4 Hex Driver
- Adjustable Wrench
- Utility Knife
- #3 Allen Wrench

## Package Contents

- 1 Understructure
- 6 Glides or Casters
- 2 Worksurface Half
- 48 M6 X 16MM Screws

## Installation

**Note:** These instructions provide basic information for installing wood tops to the base understructure. For safety purposes and to avoid damage and/or injury, it is recommended that the wood tops be installed with the base in the upright position.

1. Make sure understructure is in upright position. Unpack casters and insert one in each leg. The casters screw in and can be tightened using the adjustable wrench. (Figure A).
2. Remove all plastic ties securing the folded frame. (Figure B).
3. Unfold frame by pulling outward on outermost legs. (Figure C).

Figure A

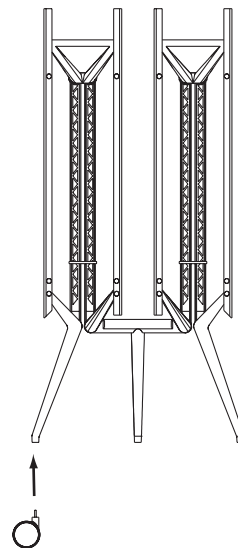

Figure B

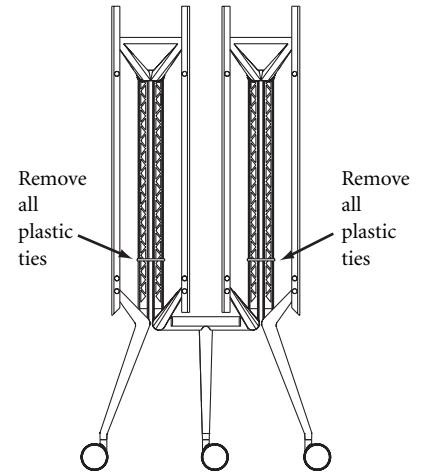
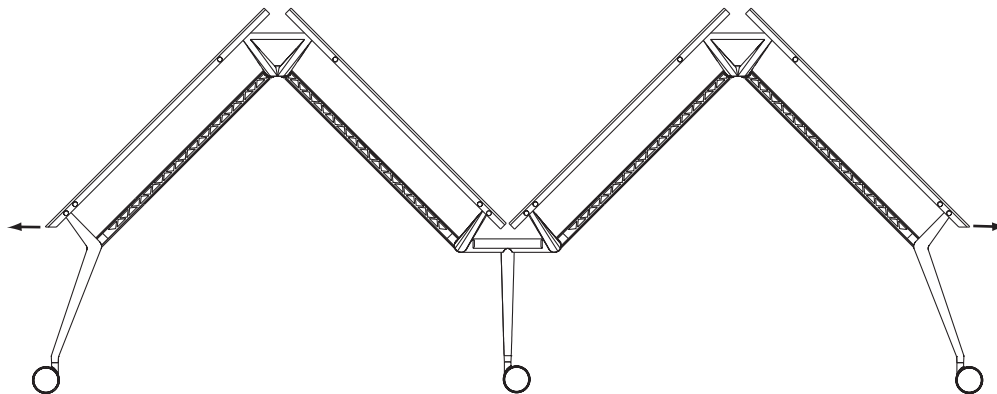

Figure C



# Aspire

## Installation (continued)

4. Fully extend frame. (Figure D).
5. Carefully lift worksurface half onto one side of frame. Match holes in frame with holes in underside of worksurface. Attach worksurface to frame using the M6 X 16MM machine screws. Tighten all screws securely. (Figure E).
6. Repeat Step 5 to attach other half of worksurface. Tighten all screws securely. (Figure F).

Figure D

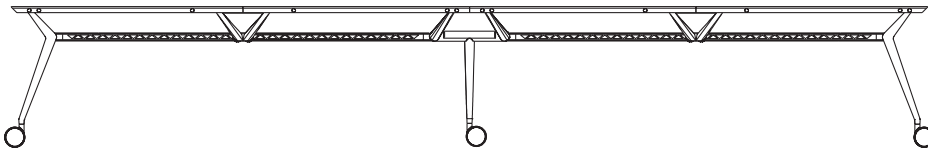

Figure E

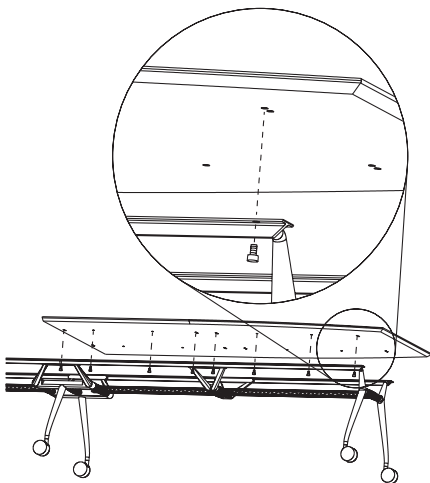
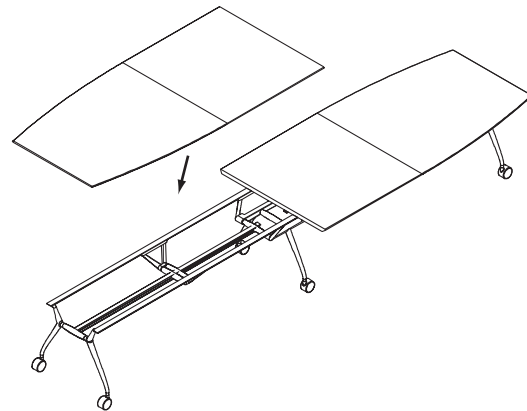

Figure F



# Aspire

## Installation (continued)

7. If the center area of the worksurface is uneven when the table is in the open position, the worksurfaces can be adjusted with set screws located under and behind the latches on each side of the table. (Figure G).
8. Check worksurfaces for unevenness. (Figure H).
9. Use the #3 Allen Wrench to adjust set screws up or down until worksurfaces are flush. (Figure I). Adjust on both sides of table, if necessary.

Figure G

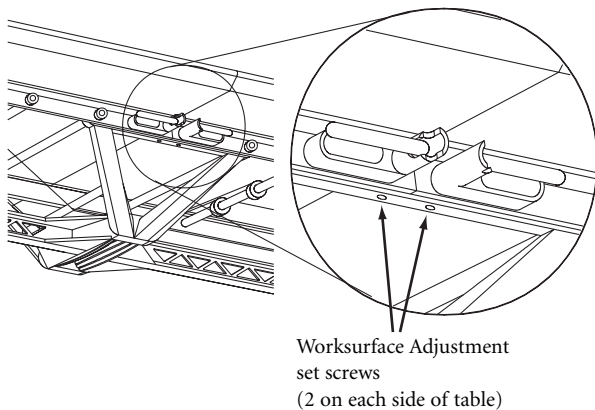

Figure H

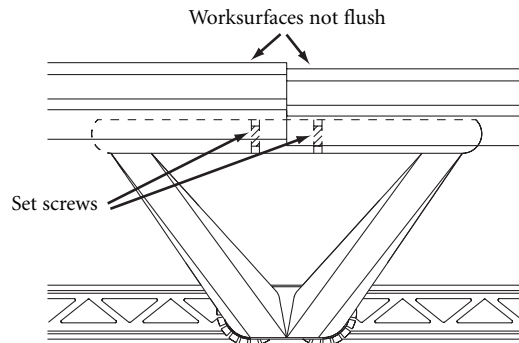

Figure I

