

Field Installing Power/Data Center

Tools Required

- Screwdriver

Package Contents

- 1 Electrical Module
- 2 Screws
- 1 Mounting Frame

Installation

1. Select mounting location for the power/data center frame.
If the frame is being mounted to a folding table, make sure it does not span any folds. Also, be sure it does not interfere with any cables or springs and that it does not block access to any locking mechanisms. (Figure A).
2. It is suggested that the power/data center be mounted where it is easily visible and accessible. (Figure B).

Figure A

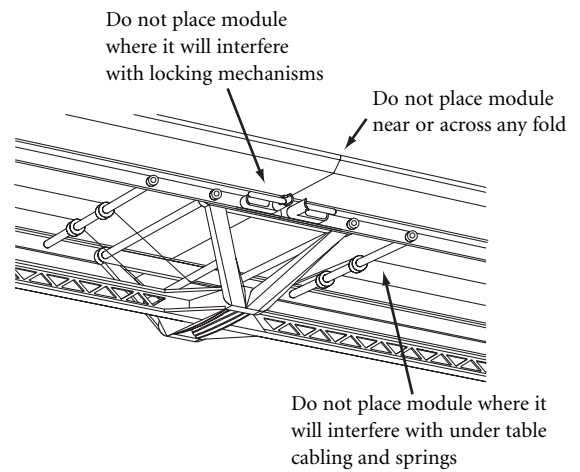
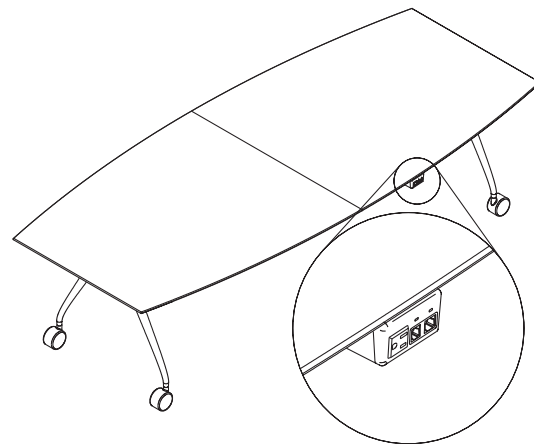

Figure B



Aspire

Installation (continued)

3. Mount frame to underside of worksurface using the two screws provided. (Figure C).
4. Pass the plug end through the frame. (Figure D). Firmly push the power/data center into frame until it snaps into place. (Figure E).

Note: *If desired, electrical module can be mounted in the frame in the inverted position.*

Figure C

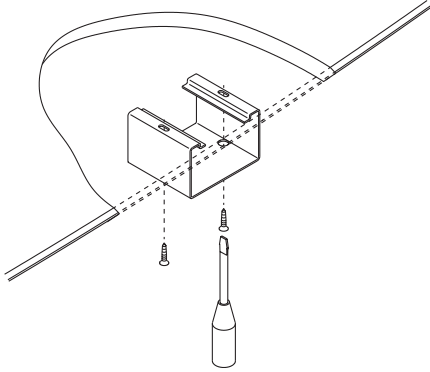

Figure D

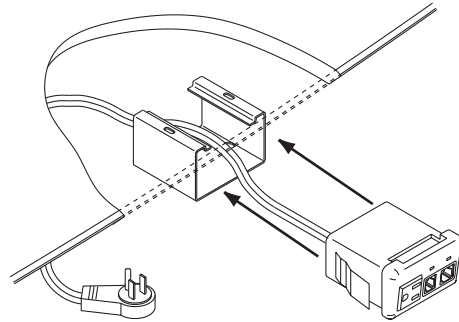

Figure E

