

# Aspire®

## 2-Piece and 4-Piece Folding Table Top Replacement

### Tools Required

- #4 Hex Driver

### Package Contents

- 2-piece Replacement Top
  - 4-piece Replacement Top
- Or,

### Installation

**Note:** This instruction explains basic installation of Aspire folding table replacement tops. Aspire folding tables have spring-tensioned cables and rollers. For safety and ease of installation, all tables must be in the fully unfolded and locked position.

**Note:** The table top flush adjustment instructions are applicable to the Aspire 2-piece Static (non-folding) top.

1. Unfold and lock table. (Figure A).
2. Remove all machine screws holding table tops to frame. (Figure B).

**Note:** Save all the removed screws. They will be used to attach the new top.

3. Before removing old top, note direction of grain and matching edges to insure proper placement of new top pieces. (Figure C).

**Note:** On the 4-piece top, the two beveled edges meet at the very center of the table top.

Then remove old pieces and set aside.

Figure A

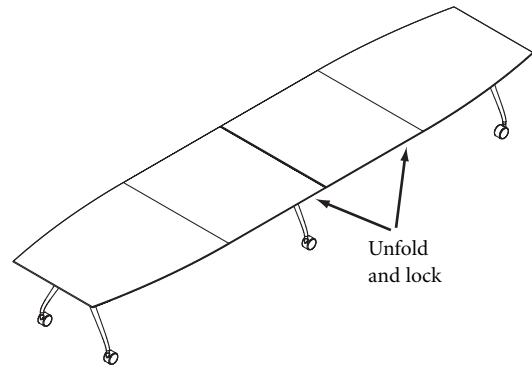

Figure B

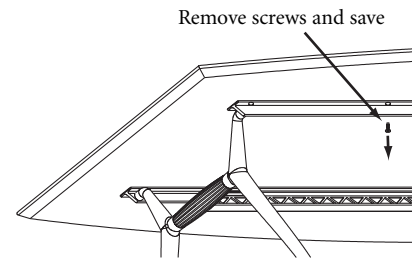
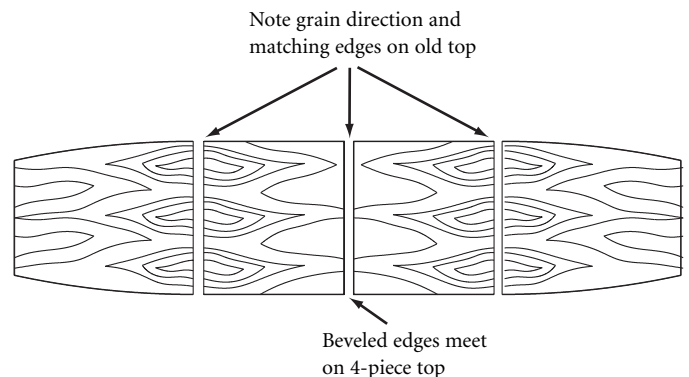

Figure C



# Aspire

## Installation (continued)

4. Place all new top pieces, in their proper locations, on the table frame. Align all holes on the undersides of the tops with their matching holes on the table frame. (Figure D).
5. Secure the replacement top pieces to the frame using the saved machine screws. Thread the screws into the inserts on the underside of the table tops. (Figure E).
6. Table tops can be made flush by means of adjustment screws located on the folding mechanisms on the table frames. On the 4-piece top the screws are located under the outer folding joints. On the 2-piece they are located under the center joint. (Figure F).

Figure D

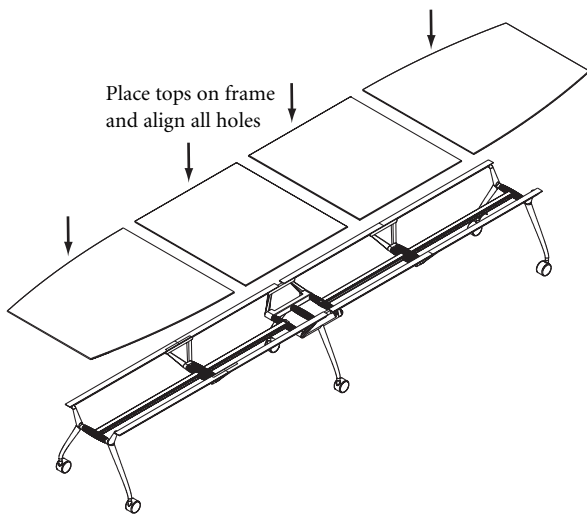

Figure E

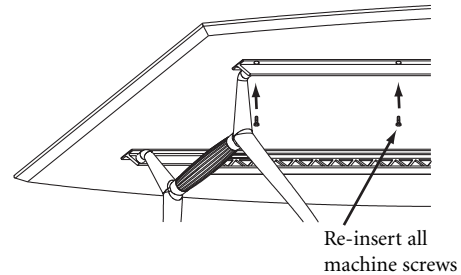
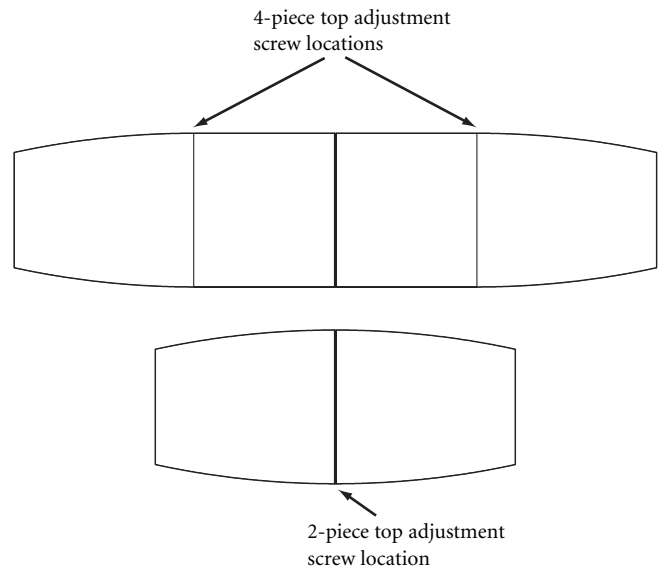

Figure F



# Aspire

## Installation (continued)

7. The set screws are in the centers of the folding mechanisms and can be accessed from underneath the mechanism cross bar. Use the hex driver to turn the set screws to adjust the height of the table tops until they are flush. (Figure G).
8. When all surfaces are flush, table is ready for use. Unlock table to return it to folded position. (Figure H).

Figure G

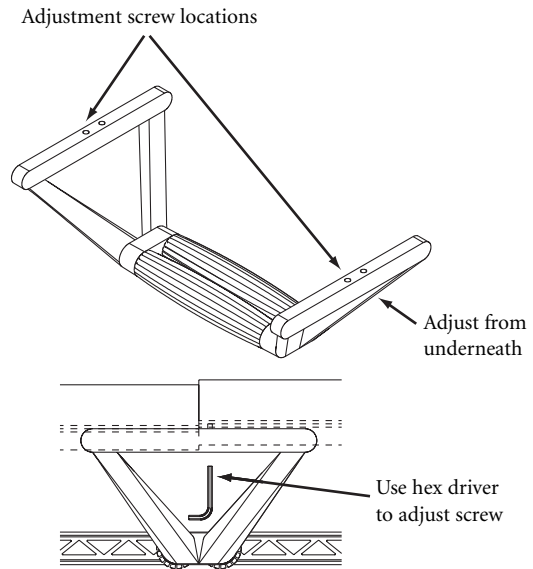
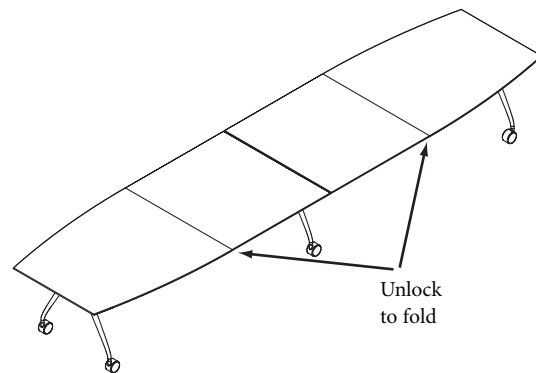

Figure H



Printed in U.S.A. © 2005 Kimball International, Inc. T 800.482.1818 F 812.482.8300

Proper product installation, in accordance with these instructions, is the responsibility of the installing agent. If you have any questions concerning these instructions, please call Kimball Office Customer Care.

Kimball<sup>®</sup>Office