

Conferencing Solutions

Power/Communication Center

Tools Required

- #2 Phillips Head Bit
- #5/32" Drill Bit
- Power Screwdriver
- Tape Measure

Package Contents

- 1 Power/Communication Center
- 4 Table Brushes (discard as they will not be used)
- AK-99 Insert Frame with Brushes
- #10 x 1/2" pan head screws
- #8 x 5/8" pan head screws
- 4 L-Brackets
- #8 x 1" pan head screws

Description

The power/communication center mounts to the underside of a table top that features an appropriately machined cutout. The power/communication center provides electrical and telecommunication access to users seated at the conference table. (Figure A)

Installation

1. Place table top upside down on a clean, hard surface.
The underside of the top has been machined with a stepped cut-out. The cut-out piece has been shipped in relative position using a flat bracket. Remove the flat bracket and discard. Retain the cut-out piece. (Figure B)
2. Unpack the power/communication center.
Note: Make sure that no items were damaged during shipping.
3. **IMPORTANT:** Pre-bore eight holes 1/2" deep using 5/32" drill bit at mounting hole locations on underside of cut-out. Attach the double-sided tape (shipped with the table top) to the flanges of the main housing. Carefully position the cut-out piece on the main housing, making sure there is equal overhang on all sides. Secure the cut-out to the main housing using eight #10 x 1/2" pan head screws. (Figure C)
Note: Watch grain direction and make sure grain will be on "top" when unit is mounted.

Figure A

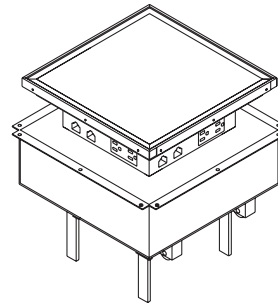

Figure B

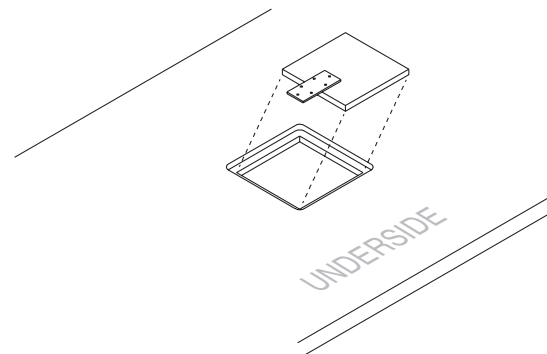
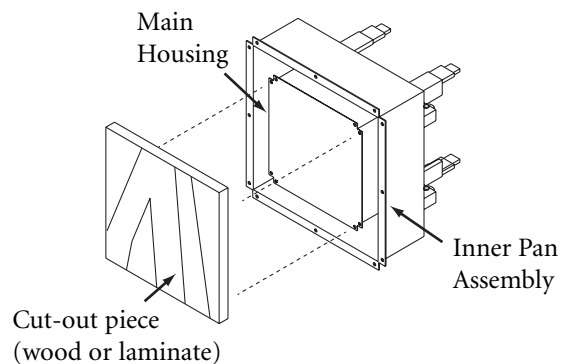

Figure C



Conferencing Solutions

Installation (continued)

4. Flip the table top right side up. Install the AK-99 insert frame/brush assembly. Press assembly firmly into opening in the table top and drill four pilot holes for a #8 screw at each of the four pre-drilled locations in the frame. Secure assembly to the table top using the four #8 mounting screws provided. (Figure D)

5. Make note of the grain direction and flip the table top upside down. Align the power/communication center inner pan assembly to the stepped cut-out in the underside of the table top.

Note: Make sure the grain on the cut-out matches the grain of the table top.

6. **IMPORTANT: The following step is critical to ensure proper stability and function of the unit.** Drill twelve holes into the table top 1/2" deep using a 5/32" drill bit at mounting hole locations on the inner pan assembly. Secure the inner pan assembly to the table top using twelve #10 x 1/2" pan head screws. (Figure E)

7. Position the four L-brackets to opposite sides of the stepped cut-out. The undrilled flanges on the L-brackets should cover the flanges on the inner housing to provide additional support to the power/communication center. Secure L-brackets to the side of the stepped cut-out using #8 x 1" pan head screws. (Figure E)

8. Attach cylinder base(s) to the underside of the table top. Place cylinder base over power/communication center and position so that the wire management cut-outs are on the centerline of the table top. Center the base on table top relative to each edge of top. Use tape measure to achieve equal distance. Fasten cylinder base to underside of table top using four #8 x 5/8" pan head screws. (Figure F)

9. Position a horizontal cable manager for wire management, if desired, between cylinder bases. (Figure G)

Figure D

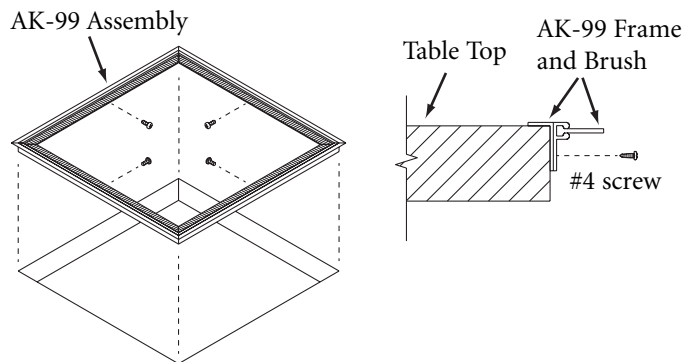

Figure E

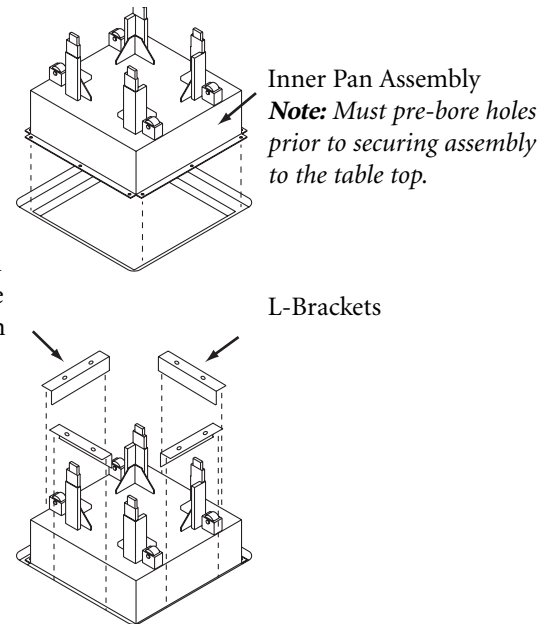

Figure F

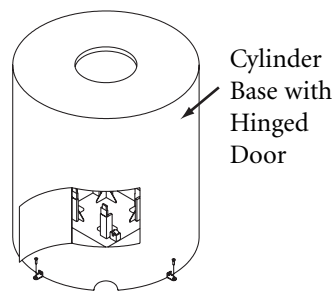

Figure G

