

Universal

Contemporary Table Tops

Tools Required

- Screw Gun
- Adjustable Wrench
- #2 Phillips Head Bit
- 7/64" Allen Wrench

Package Contents

- Levelite Bracket Covers
- #8 x 1/2" Panhead Screws

Installation

Latch Pin Assembly:

Important: Four (4) Levelites per seam are to be used on all 60" wide tables and 3 piece 48" wide tables.

1. Place the worksurface upside down on a smooth, solid surface. Match the straight ends and align the levelite brackets. (Figure A).
2. For each leveling device thread the bolt into its opposite bracket, attach nut, and tighten firmly. (Figure B).
3. After bases have been installed and table/base assembly is turned up right, use the leveling set screws in the levelite brackets to align straight ends of the assembly. (Figure B).
4. Attach the cover using the #8 x 1/2" panhead screws provided. (Figure C).

Figure A

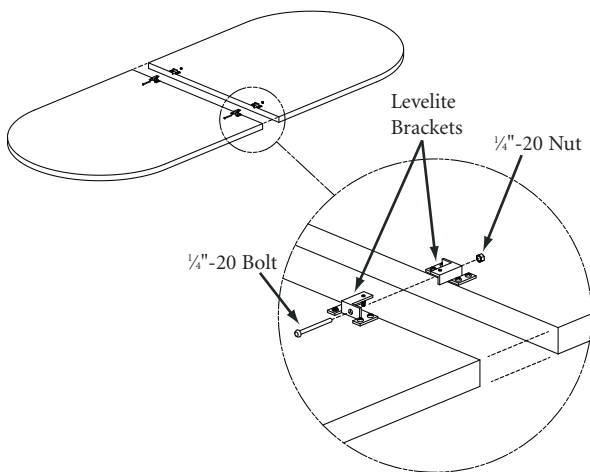
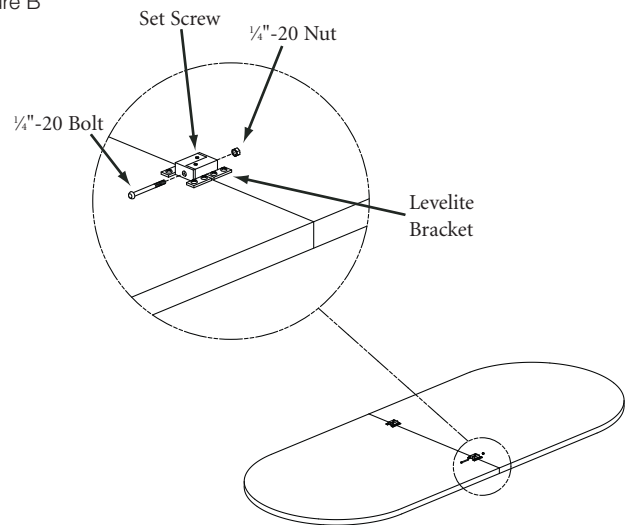
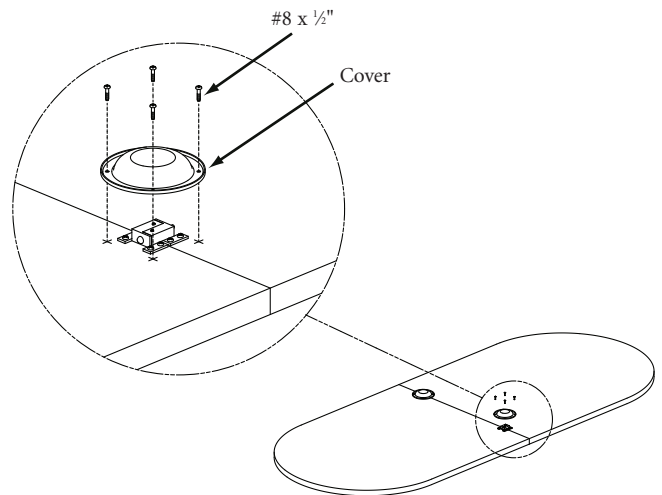

Figure B



48" Wide Tables - 2 Levelites Per Seam
(2 Piece Tops Only)

Figure C



4 Levelites Per Seam on 60" Wide Tables
and 48" Wide 3 Piece Tops