

# Traxx Jack Plates

## Tools Required

- Rubber Mallet

## Installation

1. Track jack plates sit in the channel formed by the Xsite Traxx. Place the jack plate in the channel with the bend upward. (Figure A).
2. Place track jack plates spaced in top channel as follows:  
 18" - 24" Top Cap - 1 per      54" - 72" Top Cap - 3 per  
 30" - 48" Top Cap - 2 per      78" - 96" Top Cap - 4 per  
 (Figure B).
3. Use a rubber mallet to tap down center of track jack plate to straighten the bend. Track jack plate should appear flat. If the plate does not fit snugly after being straightened, it is not needed in that particular location. Slide the plate to the left or right until it fits snugly. When the jack plate fits securely, it pushes the top channel out to the appropriate width to hold the top cap in place. (Figure C).
4. To remove the track jack plate, use a rubber mallet to tap the center of the plate down to the inverted position. Remove the plate and save for future use. (Figure D). The plate can be re-used by turning it so that the bend is in the upward position. Follow Steps 2 and 3 to install the track jack plate.

Figure B

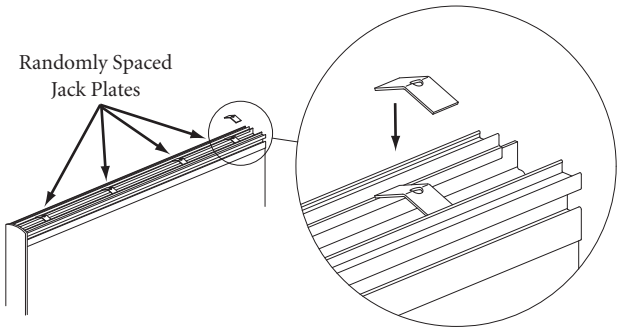

Figure C

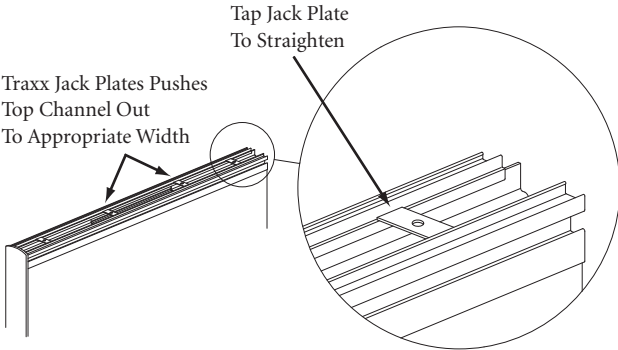

Figure D

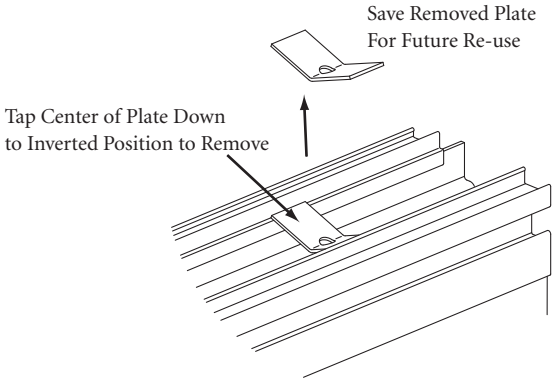
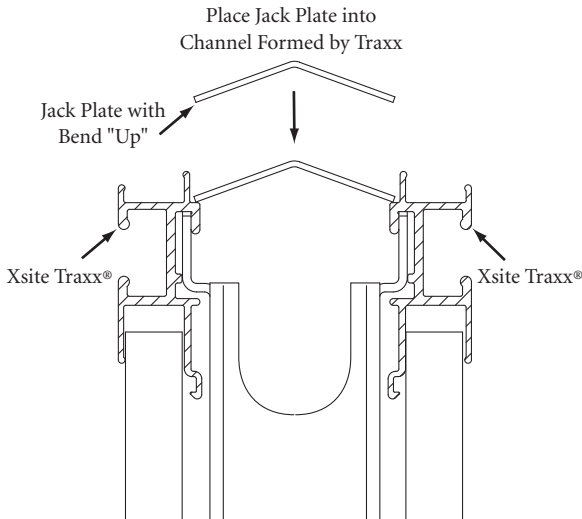

Figure A



Printed in U.S.A. © 2009 Kimball International, Inc. T 800.482.1818 F 812.482.8300

Proper product installation, in accordance with these instructions, is the responsibility of the installing agent. If you have any questions concerning these instructions, please call Kimball Office Customer Service.

Kimball®Office