Configuration Tables Assembly Instructions

1998768 Revision A-11
Complete Series Master Packet

Proper product installation, in accordance with these instructions, is the responsibility of the installing agent.
If you have any questions concerning these instructions, please call Kimball Office Customer Service.

© 2011 Kimball International, Inc. T 800.482.1818 F 812.482.8300

Conferencing Solutions

Folding T-Leg

Tools Required

- #2 Phillips Head Bit
- Power Screwdriver
- Tape Measure

Package Contents

- 2 Folding T-Leg
- 20 #12 x 1" Panhead Screws

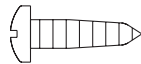

Installation

1. The Folding T-Leg is mounted to the underside of the table top. Position the legs so that they are an equal distance from either end of the table, along the centerline of the top. Space them so they do not interfere with each other when they are in the folded configuration. (Figure A).
2. To release, push down on the lever with either your thumb or foot. This allows the T-leg to pivot. (Figure B).
3. To lock, push down on the lever and move the T-leg to the full upright position. The lever/latch will snap and lock into position. (Figure C).

Figure A

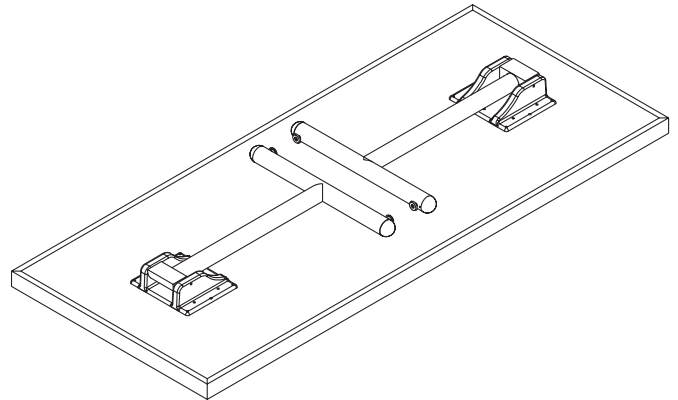

Figure B

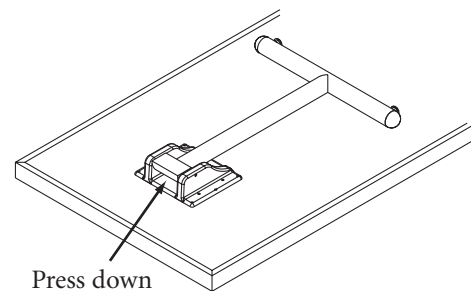
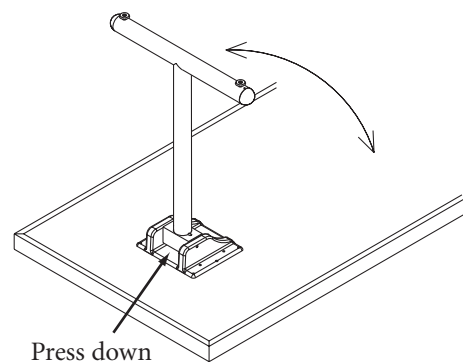

Figure C



Conferencing Solutions

Tables Assembly Instructions

Tools Required

- # 2 Phillips Head Bit
- Power Screwdriver
- Tape Measure

Package Contents

- Tapered Column Leg (Quantity per order)
- # 12 X 1" Panhead Screw (Quantity of 7 per leg)

Installation

1. The Tapered column Leg comes either as a static or mobile (caster) leg. The lower leveler and/or caster must be threaded into the nut assembly at the bottom of the leg. (Figure A).
2. Make sure work area is clean. Place worksurface upside down on a smooth, hard surface. To attach leg to rectangular worksurface, position leg approximately 2 1/2" off the inside edge of the worksurface edgeband. Attach each leg with seven #12 x 1" panhead screws. (Figure B).
3. When installing legs on trapezoid shaped tops, make sure to turn legs outward from the center of the table. Position the legs approximately 2 1/2" off the inside edge of the worksurface edgeband. Attach each leg with seven #12 x 1" panhead screws. (Figure C).
4. When installing legs on crescent shaped tops, make sure to turn legs outward from the center of the table. As a general rule, the center of the leg is located 4" from the edge of a flat rim, and 5" from the edge of a knife edge. Attach each leg with seven #12 x 1" panhead screws. (Figure D).

Figure A

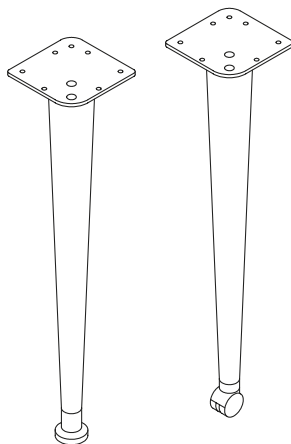

Figure B

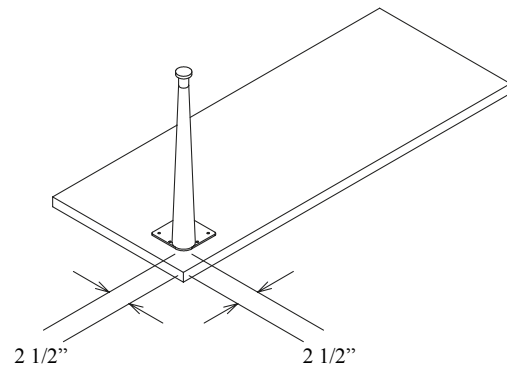

Figure C

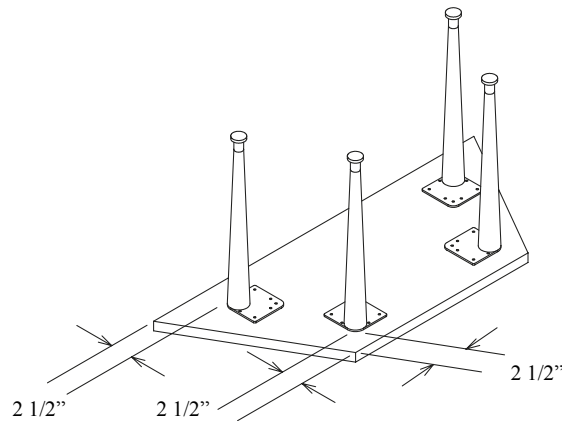
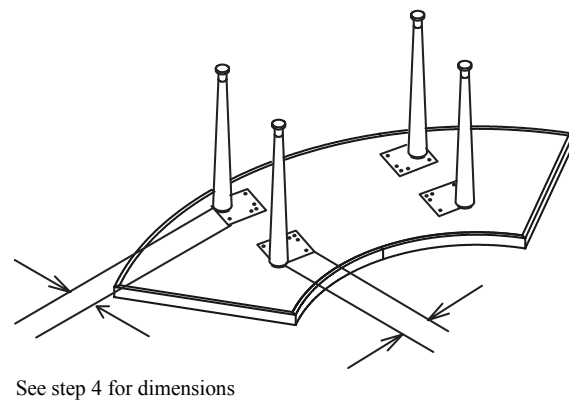

Figure D



Conferencing Solutions

Tables Assembly Instructions

5. When installing legs on quarter round tops, make sure to turn legs outward from the center of the table. Position the legs approximately 2 1/2" off the inside edge of the worksurface edgeband. Attach each leg with seven #12 x 1" panhead screws. (Figure E).
6. When installing legs on half round tops, make sure to turn legs outward from the center of the table. Position the legs approximately 2 1/2" off the inside edge of the worksurface edgeband. Attach each leg with seven #12 x 1" panhead screws. (Figure F).

Figure E

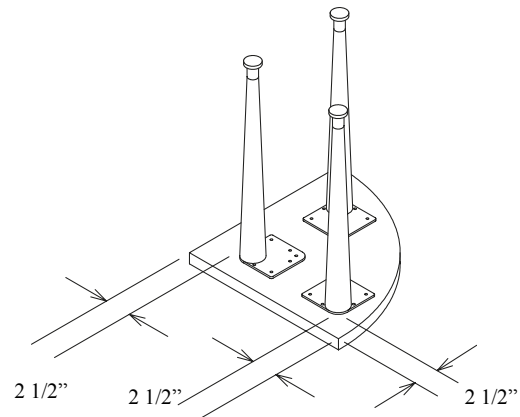

Figure F

