

Conferencing Solutions

Folding T-Leg

Tools Required

- #2 Phillips Head Bit
- Power Screwdriver
- Tape Measure

Package Contents

- 2 Folding T-Leg
- 20 #12 x 1" Panhead Screws

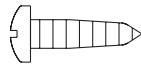

Installation

1. The Folding T-Leg is mounted to the underside of the table top. Position the legs so that they are an equal distance from either end of the table, along the centerline of the top. Space them so they do not interfere with each other when they are in the folded configuration. (Figure A).
2. To release, push down on the lever with either your thumb or foot. This allows the T-leg to pivot. (Figure B).
3. To lock, push down on the lever and move the T-leg to the full upright position. The lever/latch will snap and lock into position. (Figure C).

Figure A

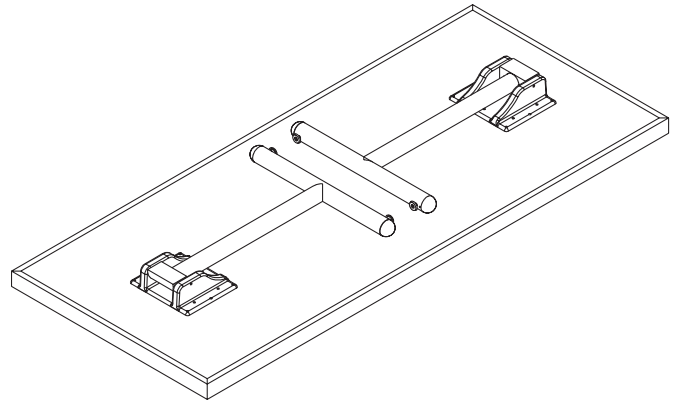

Figure B

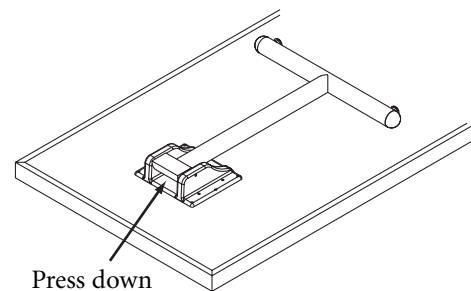

Figure C

