

Scenario™

Ganging Kit

Tools Required

- 8mm Metric Allen Wench

Package Contents

- Ganging Hook
- Ganging Shroud

Installation

1. The ganging kit consists of a hook and a shroud casting. (Figure A).
2. They fit into the leg assembly and are held in position with a M10 x 100 bolt included in leg assembly. Insert the hook ganging mechanism into the right side of the table. Align the mechanism so it is parallel to the underside of the table top. Assemble to table using M10 x 100 bolt (part of table base assembly). Attach the shroud ganging mechanism to the left side of the table. Assemble using M10 x 100 bolt (part of table base assembly). (Figure B).

Note: If adding ganging kit at a later date, then note the (2) M10 x 100 bolts must be removed from base legs and used to attach ganging mechanisms.

3. To gang the tables together, lift the shroud connector approximately 1/4" and place it over the hook connector on the adjacent table. (Figure C).

Figure A

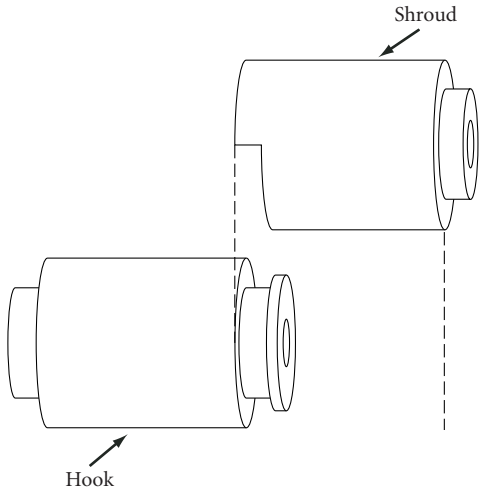

Figure B

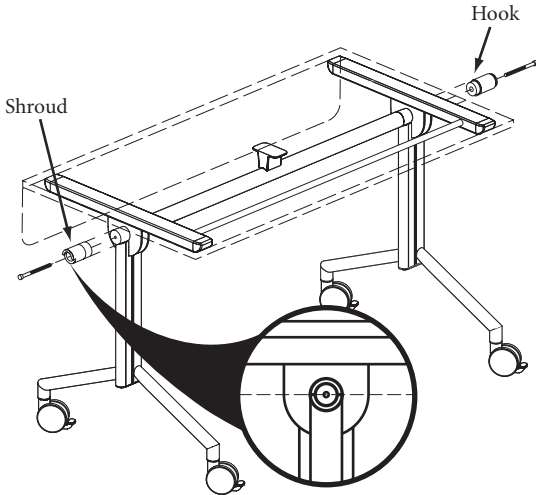
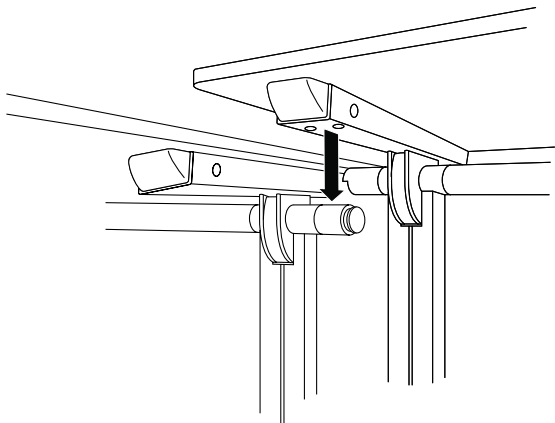

Figure C



Printed in U.S.A. © 2007 Kimball International, Inc. T 800.482.1818 F 812.482.8300

Proper product installation, in accordance with these instructions, is the responsibility of the installing agent. If you have any questions concerning these instructions, please call Kimball Office Customer Service.

Kimball®Office