

Scenario™

Desktop Power/Data

Tools Required

- Flathead Screwdriver

Installation

1. The worksurface has been pre-machined with a rectangular cut-out. The desktop power/data module is positioned into the hole in the worksurface. (Figure A).
2. The black metal U-clip slides onto the V-grooved tabs on the underside of the power/data module. Push it toward top with a screwdriver until it is tight against the underside of the top. (Figure B).

Figure A

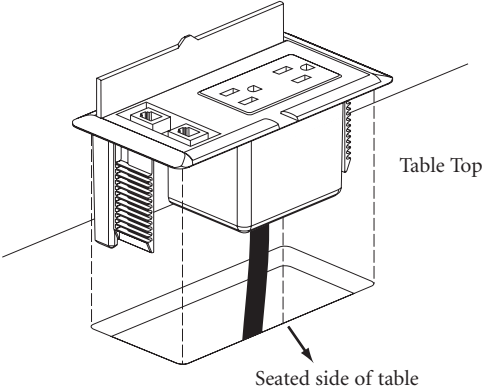

Figure B

