

Scenario™

Trainer's Desk/Podium/ Equipment Cart

Tools Required

- Phillips Screwdriver #2 Bit
Hardened

Package Contents

- (6) #10 x ½" Flathead Screws
- (16) #10 x ½" Panhead Screws
- (4) #8 x ½" Panhead Screws
- (2) Metal L-brackets
- (2) Cable Clips

Installation

1. The trainer's desk/podium/equipment cart may be used with either the height-adjustable X-base, or the fixed height X-base. The table bases have already been pre-assembled. (Figure A).
Stop: If your unit has the worksurface mounted power data unit, please reference Desktop Power/Data instruction sheet 2040757 before proceeding.
2. Place the table top on a clean dry surface with the underside facing upward. The underside of the worksurface has holes pre-bored for attachment of the base. Align the base so the table legs point to the four corners of the table. (Figure B).
3. Attach the table base to the table top using (6) #10 x ½" flathead screws provided. Height-adjustable X-bases have a cable release paddle. Remove the cover from the release paddle and attach to underside of table using (2) #8 x ½" panhead screws provided. Replace cover. Attach cable clips to underside of table using (2) #8 x ½" panhead screws provided. (Figure C).

Figure A

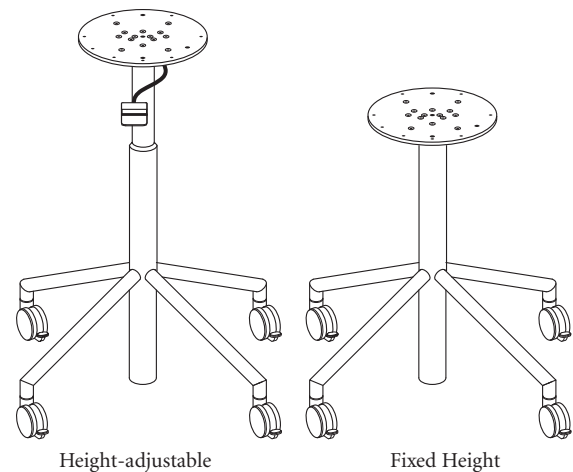

Figure B

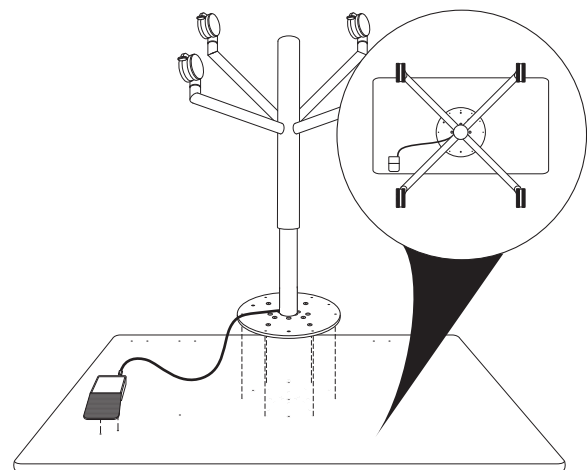
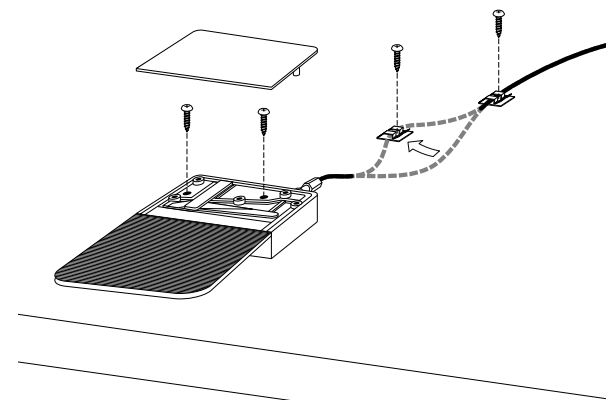

Figure C



Proper product installation, in accordance with these instructions, is the responsibility of the installing agent.
If you have any questions concerning these instructions, please call Kimball Office Customer Service.

Kimball®Office

Scenario

Installation (continued)

4. Attach the (2) metal L-brackets to the underside of the worksurface using (8) #10 x 1/2" panhead screws provided. (Figure D).
5. Flip the table and attach the front panel to the table assembly using (8) #10 x 1/2" panhead screws provided. (Figure E).

Figure D

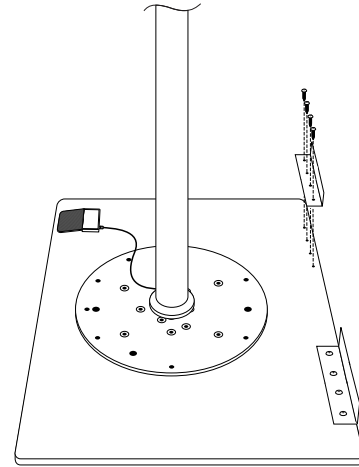

Figure E

