

# Traditional

## Conference Table Top/Bases

### Tools Required

- Adjustable Wrench
- Phillips Screwdriver or Socket Set
- Phillips Screwdriver

### Package Contents

- Table Top
- 2 Mounting Pads
- Adjustable Glides
- 28 Bolts
- 28 Washers

**Caution:** It is recommended that more than one person be used to assemble and move conference tables.

### Installation

1. Place the table top upside down on a smooth, solid surface. Match the straight ends and align the mechanical leveling devices. (Figure A).
2. For each leveling device, thread the bolt into its opposite bracket, attach nut, and tighten firmly. (Figure B).
3. Position the two mounting pads so that the holes in the mounting pad align with the T-nuts in the top. (Figure C).
4. After bases have been installed and table/base assembly is turned upright, use the leveling set screws in the leveling devices to align straight ends of the assembly. (Figure B).

Figure A

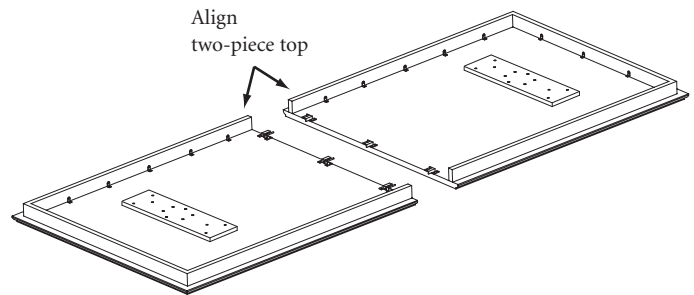

Figure B

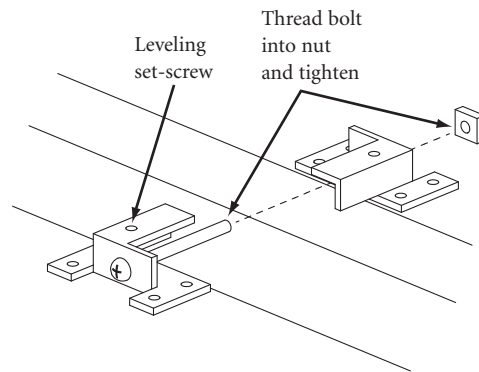
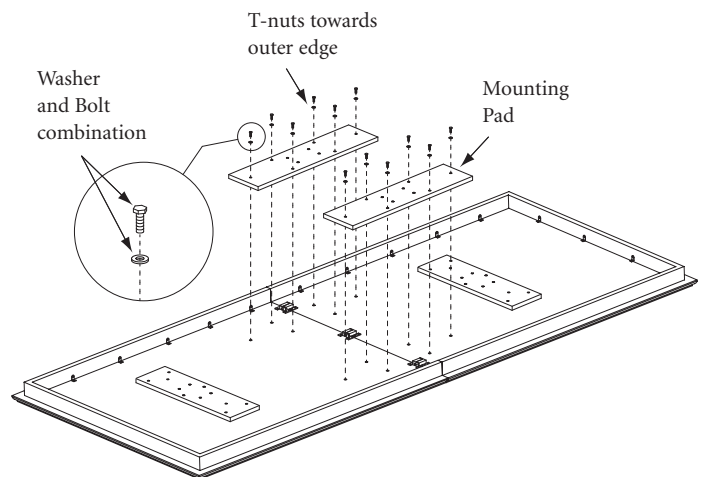

Figure C



# Traditional

## Conference Table Top/Bases

### Installation (continued)

5. Position the bases on their mounting pads. Align the six (6) mounting holes in each pedestal base with the holes in each mounting pad, the center pedestal base will align with four (4) holes in the mounting pads. Use six (6) bolts and washers to attach each base to the mounting pads, four (4) bolts and washers for the center pedestal base. (Figure D).
6. Insert adjustable glides into each base. (Figure E).
7. Carefully turn assembled unit upright. (Figure F).

**Note:** Follow the same installation steps for both the panel base and the Queen Anne base.

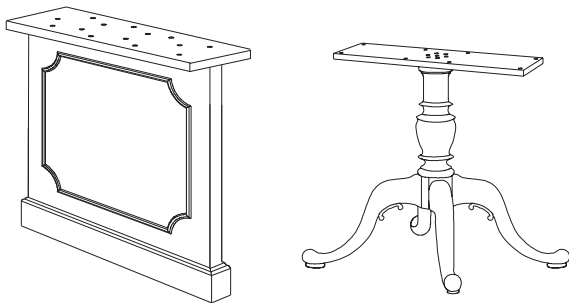

Figure D

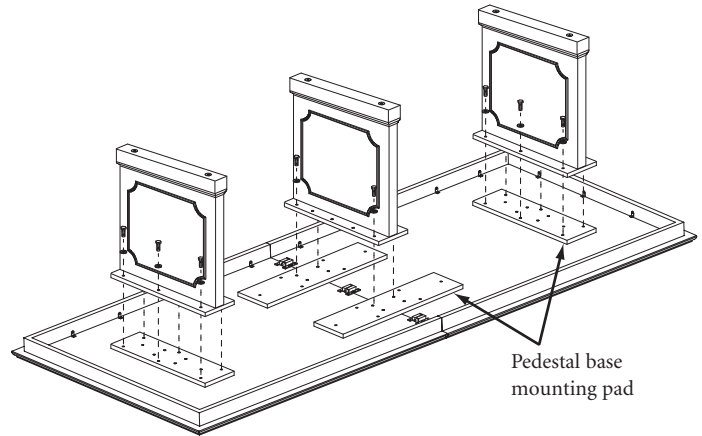

Figure E

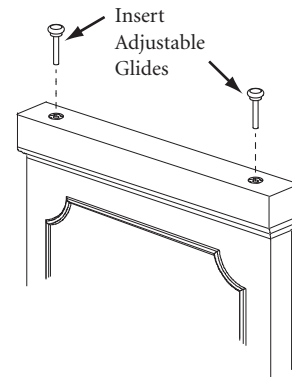
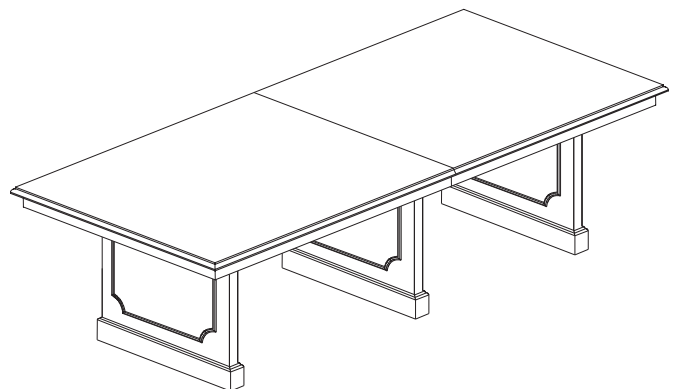

Figure F



Printed in U.S.A. © 2008 Kimball International, Inc. T 800.482.1818 F 812.482.8300

Proper product installation, in accordance with these instructions, is the responsibility of the installing agent. If you have any questions concerning these instructions, please call Kimball Office Customer Service.

Kimball<sup>®</sup>Office